



MOTOROLA

Enterprise Wireless LAN Antenna

Specification Guide

Version 1.5 December 2009

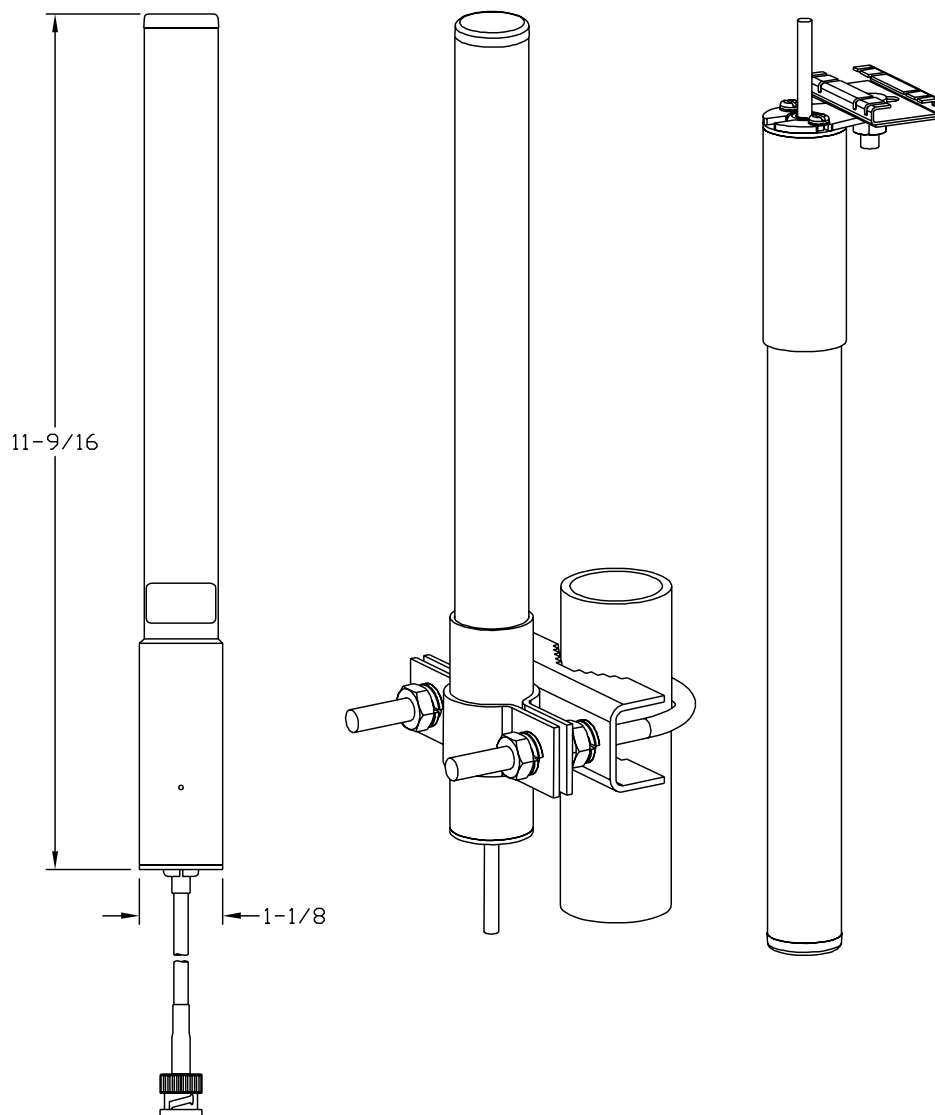

© 2009 Motorola, Inc. All rights reserved.

MOTOROLA and the Stylized M Logo are registered in the US Patent & Trademark Office. Symbol is a registered trademark of Symbol Technologies, Inc. All other product or service names are the property of their respective owners.

Contents

Chapter 1. Antenna Selection and Description

1.1 Antenna Selection	1-1
1.2 Antenna Selection Criteria	1-6
1.3 Antenna Accessories for Motorola Enterprise WLANs	1-7

Chapter 2. Product Compatibility

2.1 FCC/USA Compatibility	2-1
2.2 Antenna Suite Summary	2-3

Chapter 3. 2.4 GHz Single Band Antenna Suite

3.1 Supported 802.11b/g/n Antenna Suite	3-1
-----------------------------------------------	-----

Chapter 4. 5.2 Ghz Single Band Antenna Suite

4.1 Supported 802.11a/n Antenna Suite	4-1
---------------------------------------------	-----

Chapter 5. 2.4GHz - 5.2GHz Dual Band Antenna Suite

5.1 Supported 802.11a/b/g/n Dual Band Antennas	5-1
------------------------------------------------------	-----

Chapter 6. Antenna Cables

6.1 Supported Antenna Cables	6-1
------------------------------------	-----

Chapter 7. Supported Antenna Adapters

7.1 Supported Adapters	7-1
------------------------------	-----

Chapter 8. Supported Lightning Arrestors

8.1 Lightning Arrestors	8-1
-------------------------------	-----

Chapter 9. Mounting Kits

9.1 Mounting Kit Support	9-1
--------------------------------	-----

Chapter 10. AP-5131 Antenna Connections

10.1 2.4 GHz AP-5131 Antenna Connections	10-2
10.2 5 GHz AP-5131 Antenna Connections	10-9

Chapter 11. AP300 Antenna Connections

11.1 2.4 GHz AP300 Antenna Connections	11-1
11.2 5 GHz AP300 Antenna Connections	11-8

Chapter 12. AP 7131 Transmit Power

12.1 Configuring the AP 7131 Series Transmit Power	12-1
12.2 US Regulatory Domain 2.4 GHz Band	12-8
12.3 US Regulatory Domain 5.2 GHz Band	12-13
12.4 Japanese TELEC Regulatory Domain 2.4 GHz Band	12-23
12.5 Japan TELEC Regulatory Domain 5.2 GHz Band	12-27

Chapter 13. AP650 Regulatory Domains

13.1 US Regulatory Domain 2.4 GHz Band	1-1
13.2 US Regulatory Domain 5 GHz Band	1-7
13.3 Japan TELEC Regulatory Domain 2.4 GHz Band	1-19
13.4 Japan TELEC Regulatory Domain 5 GHz Band	1-25
13.5 EU Regulatory Domain 2.4 GHz Band	1-37
13.6 EU Regulatory Domain 5 GHz Band	1-43

Appendix A. Technical Support

About This Guide

Introduction

This guide provides an RF engineer a catalog of antenna parts and accessories to complete a customized RF environment. This guide specifically addresses the antennas used for 2.4 GHz, 5.2 GHz and dual band antenna implementations for *Wireless Local Area Networks* (WLANs).

It is important to understand that antenna and accessory selection should be qualified by on-site testing with the actual components used. Signal attenuation is cumulative with each connection and component added between the antenna and the radio, so careful study should verify the given arrangement delivers the expected results.



NOTE: Illustrations displayed in this guide are samples and can differ from the actual antenna.

Document Conventions

The following conventions are used in this document to draw your attention to important information:



NOTE: Indicate tips or special requirements.



CAUTION: Indicates conditions that can cause equipment damage or data loss.



WARNING! Indicates a condition or procedure that could result in personal injury or equipment damage.

Notational Conventions

The following additional notational conventions are used in this document:

- *Italics* are used to highlight the following:
 - Chapters and sections in this and related documents
 - Dialog box, window and screen names
 - Drop-down list and list box names
 - Check box and radio button names
 - Icons on a screen.
- **GUI** text is used to highlight the following:
 - Screen names
 - Menu items
 - Button names on a screen.
- bullets (•) indicate:
 - Action items
 - Lists of alternatives
 - Lists of required steps that are not necessarily sequential
- Sequential lists (those that describe step-by-step procedures) appear as numbered lists.

Antenna Selection and Description

1.1 Antenna Selection

While several antennas may work in a given environment, some will provide better coverage than others. Using the right antenna in the right location will maximize both the performance and coverage of your network. Understanding the key characteristics that describe how an antenna sends and receives radio frequency signals is critical to finding the ideal antenna for your deployment. This guide supports the antennas used for an AP-5131, AP-5181 or AP-7131 series access point and the AP650 and AP300 (non-integrated antenna) model access ports.

Motorola Enterprise Wireless LAN products operate in the 2.4 GHz and 5 GHz ISM bands allocated for unlicensed use. Access point and access port products available today support either the 802.11b/g/n or the 802.11a/n standard, or both. Wireless devices conforming to the 802.11b/g standard operate in the 2.4 GHz ISM band, while 802.11a devices operate in the 5 GHz band. The antennas in this guide are grouped according to the frequency band they support. Some antennas are designed to operate within either band. These antennas (described as "Dual-band") may be connected to radios operating in either the 2.4 or 5 GHz bands, although a single antenna may not be connected to two radios at the same time.

1.1.1 Connector Types and Definitions

There are combinations of antenna types and cables required to provide a satisfactory connection to the AP. One confusing factor is "reverse polarity". Reverse polarity is the FCC's requirement for each WLAN manufacturer to have unique access point connectors. Motorola (Symbol) had previously standardized our offerings for access points/ports:

- 2.4 GHz is Reverse polarity BNC female (RP-BNC-F)
- 5 GHz is reverse polarity SMA female (RP-SMA-F)
- Dual Band is reverse polarity SMA female (for AP-5131), and N-Female (for AP-5181).



NOTE: Reverse polarity presents confusion because of a lack of a standardized definition from connector manufactures. Reverse polarity provides a center element, which should not be confused with a male connector. A male connector is defined by the outer jacket of the connector rather than the center element.

The following are the connectors used within this guide:



Figure 1.1 RP-BNC-F



Figure 1.2 RP-BNC-M



Figure 1.3 RP-SMA-F



Figure 1.4 RP-SMA-M

Additionally, antennas deployed outdoors and industry standard accessories (like lightning arrestors) use Type-N connectors (as displayed below). Therefore, with the combinations devices required (access points/ports, antennas, cable extensions, and lightning arrestors), various adapter cables are required to connect an antenna to an access point/port.



Figure 1.5 Type N-F



Figure 1.6 Type N-M

1.1.2 Indoor and Outdoor Antennas

One important aspect of an antenna is whether it is weather sealed to protect it from the environment. Because of this extra protection, outdoor antennas are typically more expensive than those rated for indoor use. Outdoor antennas can be used for indoor applications, such as freezers and cooler where moisture is common. Outdoor antennas can be used for indoor applications, but indoor applications should not be used in outdoor applications.

One common distinction of outdoor antennas is the connector. Since lightning protection is always advised for outdoor antennas, these antennas typically have Type N Male to directly attach the lightning arrestor. This is true of the 2.4 GHz, 5 GHz, and the dual-band outdoor antennas.

1.1.3 Spectrum and Part Number Designations

The antennas listed in this document are ultimately referenced by part number. A numerical sequence is used within each antenna's part number to identify the spectrum supported by the antennas.

- The antenna part numbers with a 2499 indicates a 2.4 GHz antenna. For more information on the 2.4 GHz antenna suite, see [2.4 GHz Single Band Antenna Suite on page 3-1](#).
- The antenna part numbers with a 5299 indicates a 5 GHz antenna. For more information on the 5 GHz antenna suite, see [5.2 GHz Single Band Antenna Suite on page 4-1](#).
- The antenna part numbers with a 2452 indicates a dual band antenna (2.4GHz and 5 GHz). For more information on the 2.4 GHz antenna suite, see [2.4GHz - 5.2GHz Dual Band Antenna Suite on page 5-1](#).

1.1.4 Extended AP to Antenna Cable Lengths

Most indoor antennas are intended to be mounted directly to the AP's connectors. Some mounting arrangements call for positioning the AP a significant distance away from the antenna due to serviceability or other reason. In these situations, various adapters and cable extensions are required.

In these situations be mindful of:

- The connector on the AP
- The connector on the antenna
- The spectrum being implemented
- Signal loss due to multiple connectors and long cable lengths

Combinations of these attributes present different parts required to complete the connection. The Product Compatibility matrix addresses the parts required to make a proper connection. For more information, see [FCC/USA Compatibility on page 2-1](#).

1.2 Antenna Selection Criteria

In addition to antenna frequency, there is other criteria to consider when selecting an antenna.

1.2.1 Antenna Pattern

1.2.1.1 Omni-Directional

Signal radiates from the antenna in all directions on the horizontal plane.

1.2.1.2 Directional

Signal radiates in a specific direction, typically described as a beam of given width, expressed in degrees in the horizontal and vertical plane. For more information, see [Azimuth 3dB Beamwidth on page 1-7](#) and [Elevation 3dB Beamwidth on page 1-7](#).

1.2.2 Antenna Type

1.2.2.1 Panel

A panel antenna is a flat antenna mounted to a wall or other vertical surface and radiates RF energy (radio waves) directionally away from the wall. They usually have gain greater than 5 dBi and are not suitable for omni-directional situations. Ideally suited for long hallways.

1.2.2.2 Patch

A patch antenna is a flat antenna mounted on the ceiling but whose pattern is omni-directional. Most of the energy goes out horizontally to the sides of the antenna and equal in all directions.

1.2.2.3 Dipole

A dipole antenna is a tubular antenna that can be either a pipe shape, a straight flexible rod or a paddle. This antenna has an omni-directional pattern when placed in a vertical position. It usually has 2 dBi of gain.

1.2.2.4 Dipole Array

Essentially a dipole, a dipole array is two or more dipoles that are placed one on top of the other, requiring a longer tube to hold them. The advantage of a dipole array is that it has higher gain.

1.2.2.5 Parabolic Grid

A parabolic grid antenna is a very directional, dish-like antenna. Its parabolic reflector focuses the RF energy like a flashlight. Most of the time the radiating element is a dipole, but when combined with the dish, it becomes very directional with gain up to 24 dBi. Usually used in long point-to-point systems.

1.2.2.6 Yagi

A yagi antenna is an antenna that has an internal structure resembling that of typical antennas used for TV reception (a series of rods perpendicular to a main rod, making a triangular shape). This is a directional antenna with less gain than the PGA, typically around 13 dBi. It may be used in either point-to-point situations, or to cover a very long, narrow area in point-to-multi-point situations.

1.2.3 Antenna Performance Characteristics

1.2.3.1 Frequency

The frequency band within which the antenna performs at the stated specifications

1.2.3.2 Gain (dBi)

The relative amplification of the antenna with respect to an equivalent isotropic antenna, expressed on the decibel logarithmic scale.

1.2.3.3 Cable loss (dB)

The signal strength loss introduced by the cable connected to the antenna expressed on the decibel logarithmic scale.

1.2.3.4 Net gain (dBi)

The resulting amplification of the antenna paired with its cable.

1.2.3.5 Polarization

The orientation of the electrical field which the antenna is optimized to receive. If the transmitting and receiving antennas are both linear polarized, then turning one 90° so that they are cross polarized will reduce the range significantly.

1.2.3.6 VSWR

Voltage Standing Wave Ratio (VSWR) is the ratio of maximum voltage to minimum voltage along the line. Expresses the degree of match between the transmission line and the terminating element (antenna). When VSWR is 1:1 the match is perfect, a VSWR of 1.5:1 corresponds to 96% power efficiency.

1.2.3.7 Azimuth 3dB Beamwidth

Width of the antenna beam on the horizontal plane expressed in degrees.

1.2.3.8 Elevation 3dB Beamwidth

Height of the antenna beam on the vertical plane expressed in degrees.

1.3 Antenna Accessories for Motorola Enterprise WLANs

Motorola offers a complete selection of antennas and accessories to ensure optimal coverage and performance for wireless LANs. Regardless of the size or layout of your environment, from a small office or storefront to campus-wide, multiple-site, indoor and outdoor deployments, Motorola offers the antennas, cables and accessories designed to fit your needs.

By combining this portfolio with a broad line of wireless switches, access ports, access points, client connectivity cards, ruggedized mobile voice/data devices and network management software, as well as wireless mobility planning and deployment services, Motorola offers comprehensive end-to-end wireless enterprise LAN solutions, giving you secure, reliable access to your critical business data and applications at the point of activity. For more information on Motorola's wireless products, visit www.motorola.com.

1.3.1 Choosing the Right Antenna and accessories for your WLAN

It is important to consider a number of factors when choosing an antenna and accessories for your Motorola enterprise WLAN. To choose the right components, you'll need to know:

- Where is the antenna to be installed, and what type of coverage is required. Knowing the intended radio band is central. Determine if the intended radio coverage area supports dual 2.4/5.2 band traffic. Has the attenuation of the coverage been discerned in respect to known barriers.
- The band (802.11b/g/n or 802.11a/n) your network supports
- Which Motorola AP to use
- Whether you will be deploying the network indoors or outdoors
- The distance between AP and antenna, to determine extender cable length, if any
- The serviceability requirement for each AP and antenna deployment

Review the chart to determine which antennas suit your needs. Using the part numbers provided, determine which of the antennas will work with your hardware in your environment.

Product Compatibility

To find the right antenna and accessories for your AP-5131, AP-5181, AP-7131, AP650 or AP300 (non-integrated antenna) deployment:

- Find your Motorola access point or access port model at the top of the chart (refer to the chart on the following page). Follow that column down to find the antennas, cables and lightning arrestors compatible with that model access port or access point. Write those part numbers down.
- Follow the row antenna across the table to the columns for the lightning arrestors and cables you wrote down to confirm that they compatible with the antenna you've chosen and determine if an adaptor is required to connect the two selected parts.



NOTE: The product compatibility chart on the next displays a global compatibility matrix, and does not apply to FCC USA specific compatibility. For information specific to FCC USA compatibility, see [Antenna Suite Summary on page 2-3](#).

2.1 FCC/USA Compatibility

The following displays Motorola's FCC approved AP radio, antenna, cable and accessory combinations for use in the United States:

		AP Radios							Cables					LAs				
		AP300 (H9PWSAP5100)	AP300 B/G (H9PWSAP5100bg)	AP-5131 (H9PA5131)	AP-5181 (H9PA5181)	AP-7131 ABGN (UZ7AP7131)	AP-7131N ABGN (UZ7AP7131N)	AP-650 (UZ7MB82)	ML-1499-100JK-01R	ML-1499-10JK-01R	ML-1499-25JK-01R	ML-1499-50JK-01R	ML-1499-72PJ-01R	ML-1499-LAK1-01R	ML-1499-LAK2-01R	ML-2452-LAK1-01R		
Antennas	2.4 GHz	ML-2499-11PNA2-01R	*	*	3	X	3	3	3	1	1	1	1	*	2	2	2	
		ML-2499-5PNL-72-N	8	8	X	X	7	7	X	A	A	A	A	X	*	*	*	
		ML-2499-7PNA2-01R	*	*	3	X	3	3	X	1	1	1	1	*	2	2	2	
		ML-2499-APA2-01	*	*	X	X	3	3	3	X	X	X	X	X	X	X	X	X
		ML-2499-BPNA3-01R	9	9	X	X	5	5	X	*	*	*	*	X	X	*	X	
		ML-2499-BYGA2-01R	9	9	6	X	5	5	X	*	*	*	*	X	X	*	X	
		ML-2499-FHPA5-01R	8	8	9	*	7	7	7	A	A	A	A	X				
		ML-2499-FHPA9-01R	8	8	X	*	7	7	7	A	A	A	A	X				
		ML-2499-HPA3-01R	*	*	3	X	3	3	3	1	1	1	1	*	2	2	2	
		ML-2499-PNAHD-01R	*	*	3	X	3	3	X	1	1	1	1	*	2	2	2	
	ML-2499-SD3-01R	*	*	X	X	3	3	3	1	1	1	1	*	2	2	2		
	5 GHz	ML-5299-APA1-01R	*	X	*	X	*	*	*	X	X	X	X	X	X	X	X	
		ML-5299-BYGA15-012	X	X	X	X	X	*	X	*	*	*	*	X				
		ML-5299-FHPA10-01R	X	X	X	*	X	X	*	A	A	A	A	X				
		ML-5299-FHPA6-01R	X	X	X	*	*	*	*	A	A	A	A	X				
		ML-5299-HPA1-01R	*	X	*	X	*	*	*	4	4	4	4	X	5	5	5	
		ML-5299-PTA1-01R	*	X	X	X	*	*	*	4	4	4	4	X	5	5	5	
		ML-5299-WPNA1-01R	*	X	*	X	*	*	X	4	4	4	4	X	5	5	5	
	Dual	ML-2452-APA2-01	*	*	*	X	*	*	*	X	X	X	X	X	X	X	X	
		ML-2452-PNA5-01R	*	*	X	*	7	7	7	A	A	A	A	X				
		ML-2452-PNA7-01R	X	X	X	*	7	7	X	A	A	A	A	X				
		ML-2452-PTA2M3X3-1	X	X	X	X	*	*	*									
		ML-2452-PTA3M3-036	X	X	X	X	*	*	*									
		ML-2452-HPA5-036	X	X	X	X	*	*	*									
		ML-2452-PNL9M3-036	X	X	X	X	*	*	X									
	ML-2452-APA6J-01	X	X	X	X	*	*	*										

LAs	ML-1499-LAK1-01R	ML-1499-LAK2-01R	ML-2452-LAK1-01R
	X	*	X
	X	X	X
	*	X	*

*	*	*	*	X
*	*	*	*	X
*	*	*	*	X

Cables	ML-1499-100JK-01R	ML-1499-10JK-01R	ML-1499-25JK-01R	ML-1499-50JK-01R	ML-1499-72PJ-01R
	7	X	7	*	7
	7	X	7	*	7
	7	X	7	*	7
	7	X	7	*	7
	*	*	X	X	X

1	ML-1499-RBNCA1-01R
2	ML-1499-RBNCA2-01R
3	25-72178-01
4	25-90262-01R
5	25-90263-01R
6	25-85391-01R
7	25-85392-01R
8	must use ML-1499-LAK1-01R
9	25-97261-01R
A	25-99175-01R
*	Compatible
X	Not compatible
	Not required

2.2 Antenna Suite Summary

The following aligns Motorola’s antenna suite with their respective part numbers, description, band, gain, mounting orientation, radiation patterns, outdoor versus indoor deployment and plenum rating.

Part Number	Description	Cable	Peak Gain(dBi) (Note1)	Mount	Az BW	Outdoor rated	Plenum (Cable only)
ML-5299-APA1-01R	ANT:5.5 GHz, DP AJ,CBL 0,SMARTP-F	none	2	S	360	No	No
ML-5299-PTA1-01R	ANT :5.5 GHz, PTCH,CBL 36",SMARTP-F	36 in	4.6	H	360	No	Yes
ML-5299-HPA1-01R	ANT:5.5 GHz, DPA,CBL 36",RPSMA-F	36 in	5	V	360	Yes	Yes
ML-5299-FHPA6-01R	ANT:4.9-5.9 GHz, FIXED DP, TYPE N-M	none	6	V	360	Yes	No
ML-5299-FHPA10-01R	ANT:5.8 GHz, FIXED DP, TYPE N-M	none	8	V	360	Yes	No
ML-5299-WPNA1-01R	ANT:5.5 GHz, PNL,CBL 36",RPSMA-F	36 in	12.5	V	31	Yes	TBD
ML-5299-BYGA15-012	ANT: Yagi 4.9-5.5GHz	36 in	13.9	V	31	Yes	No
ML-2499-APA2-01	ANT:OMNI,2400-2500MHZ	none	2	S	60	No	No
ML-2499-HPA3-01R	ANT:S24,DP,CBL 48",BNCRP-F	48 in	3.3	V	360	Yes	TBD
ML-2499-SD3-01R	ANT:S24,PTCH,CBL 48",BNCRP-F	48 in	3.5	H	360	No	Yes
ML-2499-PNAHD-01R	ANT:S24,PNL,CBL 48",BNCRP-F	48 in	6.3	V	55	No	TBD
ML-2499-7PNA2-01R	ANT:2.4GHz,INDOOR,65 DEGREE PNL	48 in	6.3	V	60	No	Yes
ML-2499-5PNL-72-N	ANT:2.4GHz,PNL,LP,CBL 72",TYPE N	72 in	5.5	V	135	Yes	Yes
ML-2499-11PNA2-01R	ANT:S24,SECTR PNL,CBL 96",BNCRP-F	96 in	8.5	V	97	No	Yes
ML-2499-FHPA5-01R	ANT:2.4GHz,FIXED DP,TYPE N-M	none	5	V	360	Yes	No
ML-2499-FHPA9-01R	ANT:2.4GHz,FIXED DP,TYPE N-M	none	6	V	360	Yes	No
ML-2499-BPNA3-01R	ANT:S24,PNL,CBL 12",TYP N-F	12 in	13.9	V	31	Yes	TBD
ML-2499-BYGA2-01R	ANT:S24,YAGI,CBL 12",TYP N-F	12 in	14.1	V	34	Yes	TBD
ML-2499-BPDA1-01R	ANT:S24,DISH,TYP N-F	none	23.5	V	10	Yes	TBD
ML-2452-PTA2M3X3-1	ANT:11ABG,APT7131,MIMO3X3,1IN,RPSMA	n/a	3/5	S	360	No	No
ML-2452-APA2-01	ANT:2.4-5.2GHz DUALBAND,DP,SMARTP-F	none	6/7	S	360	No	No
ML-2452-PTA3M3-036	ANT:11ABG,MIMO3,PTCH,36IN,RPSMA	36 in	3/7	H	360	No	Yes
ML-2452-PNA5-36R	ANT:DUAL BAND PANEL,RP-SMA(M)	36 in	4/6	V	60	TBD	Yes
ML-2452-PNA5-01R	ANT:2.4/5 GHz,SECTOR 120,TYPE N-M	12 in	4.5/5	V	120	Yes	Yes
ML-2452-PNA7-01R	ANT:2.4/5 GHz,SECTOR 60,TYPE N-M	12 in	7/9	V	60	Yes	Yes
ML-2452-HPA5-036	ANT:11ABG,DP,CBL 36",RPSMA-M	36 in	2.9/4.9	V	360	Yes	No
ML-2452-PNL9M3-036	ANT: MIMO DUAL BAND SECTOR	36 in	11/14	V	75	Yes	Yes
ML-2452-APA6J-01	ANT:DUAL BAND, DP AJ, RP-SMA	none	-6/-8	S	360	No	No

Plenum
Outdoor
Omnidirectionals
Directionals
Patch

H - ceiling mount (Patches)
V - Wall or mast mount (Panels, Yagi, Dishes)
S - Switchable (elbow jointed)

Note 1: Peak Gain does not include cable loss.

2.4 GHz Single Band Antenna Suite

3.1 Supported 802.11b/g/n Antenna Suite

Motorola supports numerous single-band 2.4 GHz 802.11b/g/n antennas to suit the requirements of your unique access point or access port deployment. Check the Motorola Web site periodically, as newly supported 802.11b/g/n antennas will be added to this document as they are released. For more information, go to <http://support.symbol.com/support/product/manuals.do>.

For detailed information on supported 802.11b/g/n antenna models, refer to:

- *ML-2499-5PNL-72-N Outdoor 135° Panel Antenna: Male Connector*
- *ML-2499-7PNA2-01R Indoor 60° Diversity Panel: RP-BNC Male*
- *ML-2499-11PNA2-01R Outdoor 97° Sector Panel: RP-BNC Male*
- *ML-2499-APA2-01R Indoor Rubber Flex, Elbow Joint Dipole: RP-BNC Male*
- *ML-2499-BPDA1-01R Outdoor 10° High-Gain Dish: 20.5 N Female*
- *ML-2499-BPNA3-01R Outdoor 35° High-Gain Directional Panel: Type N - Female*
- *ML-2499-BYGA2-01R Outdoor 35° High-Gain Directional Yagi: N Female*
- *ML-2499-HPA3-01R High Performance Omni-Directional "Pipe" Antenna: RP-BNC Male*
- *ML-2499-PNAHD-01R Indoor 55° Directional Panel: RP-BNC Male*
- *ML-2499-SD3-01R Low Profile Ceiling/Surface Mount Omni-Directional Patch: RP-BNC Male*
- *ML-2499-FHPA5-01R Omni-Directional "Pipe" Antenna: N Male Connector*
- *ML-2499-FHPA9-01R High Performance Fixed Point Dipole: Male Connector*



NOTE: For examples on how various antenna and connectors are deployed in a 2.4 GHz AP-5131 installation, see [2.4 GHz AP-5131 Antenna Connections](#).

3.1.1 ML-2499-5PNL-72-N Outdoor 135° Panel Antenna: Male Connector

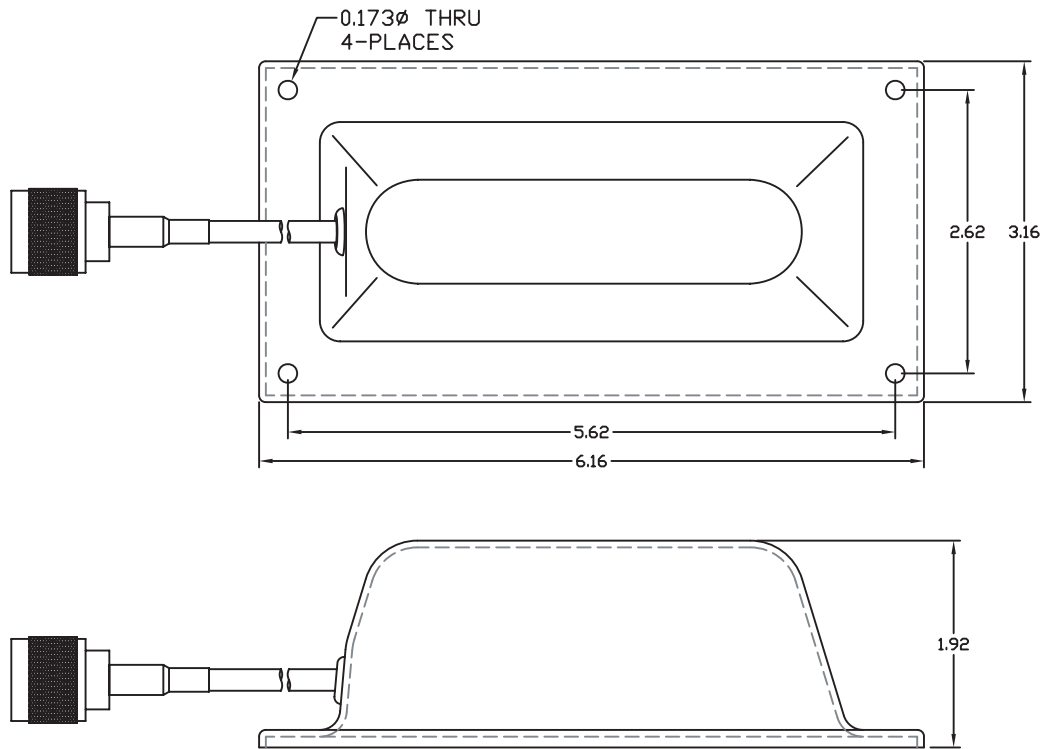

Type	Panel
Frequency	2400-2500 MHz
Gain (dBi)	5.5
Polarization	Linear, Vertical
Azimuth	3dB Beamwidth: 135°
Elevation	3dB Beamwidth: 56°
Cable Length (in.)	72
Cable Type	RG-58 Ultralink
Connector Type	Type N Male
Weight	0.5 lb
Plenum Antenna	No
Plenum Cable	Yes
Outdoor Rated	Yes

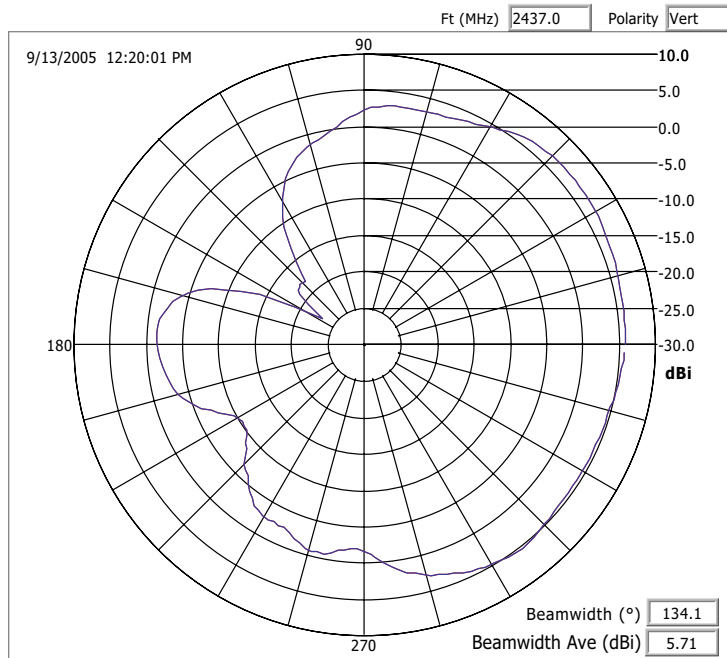

Azimuth Pattern

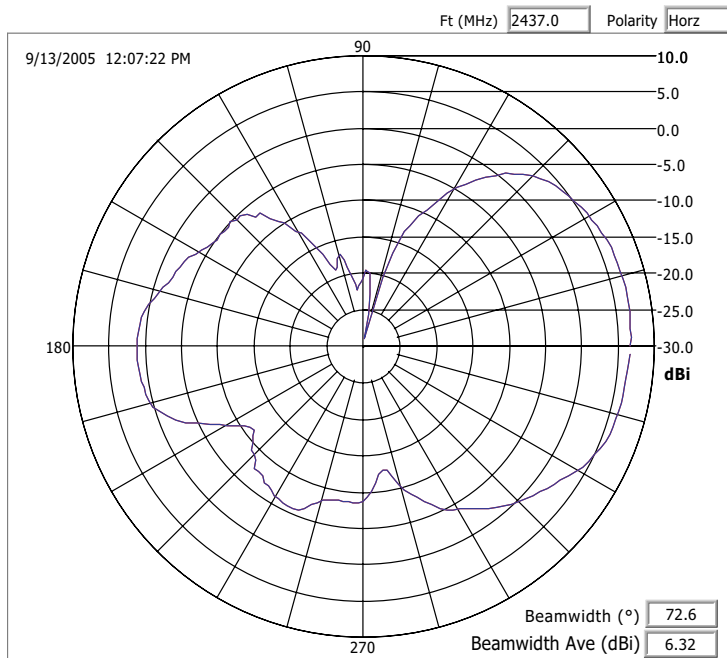

Elevation Pattern

3.1.2 ML-2499-7PNA2-01R Indoor 60° Diversity Panel: RP-BNC Male

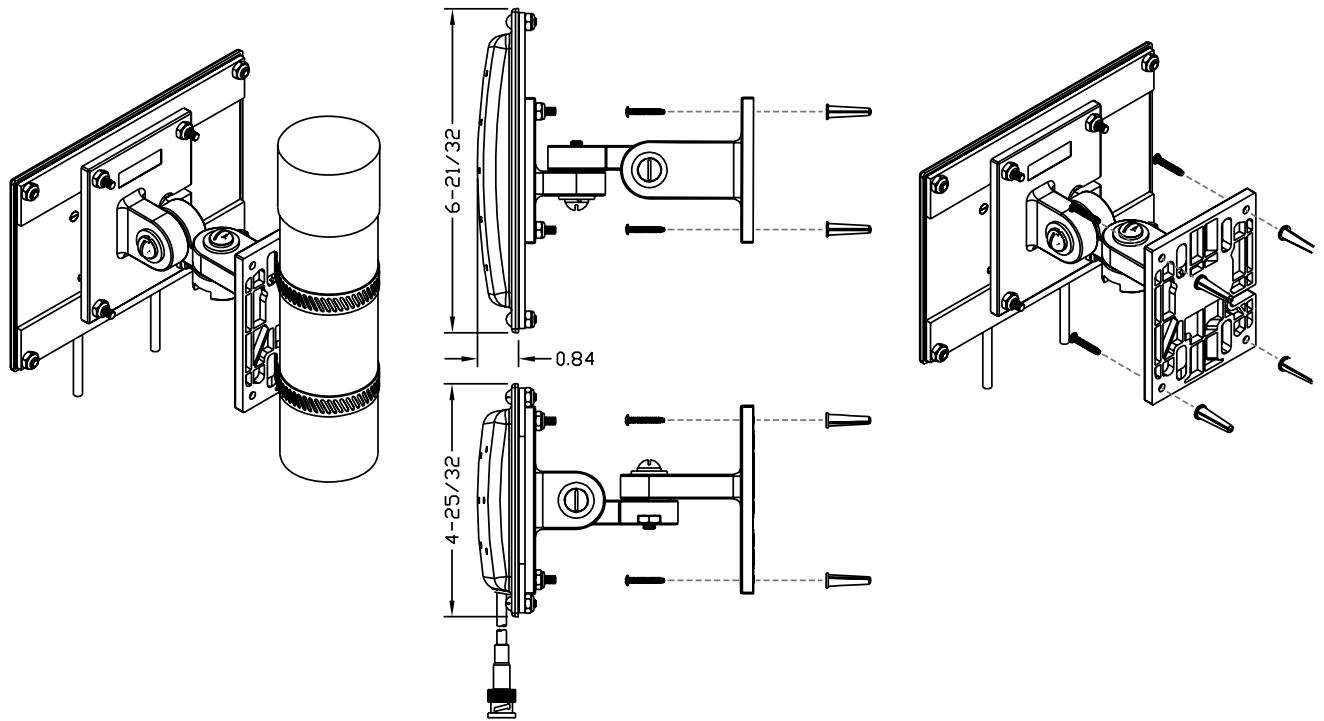

Type	Panel x 2 (Diversity)
Frequency	2400-2500 MHz
Gain (dBi)	6.3
Polarization	Linear, Vertical
Azimuth	3dB Beamwidth: 60°
Elevation	3dB Beamwidth: 60°
Cable Length (in.)	48
Cable Type	RG-58 Ultralink
Connector Type	RP-BNC Male x 2
Weight	0.6 lbs
Plenum Antenna	No
Plenum Cable	Yes
Outdoor Rated	No

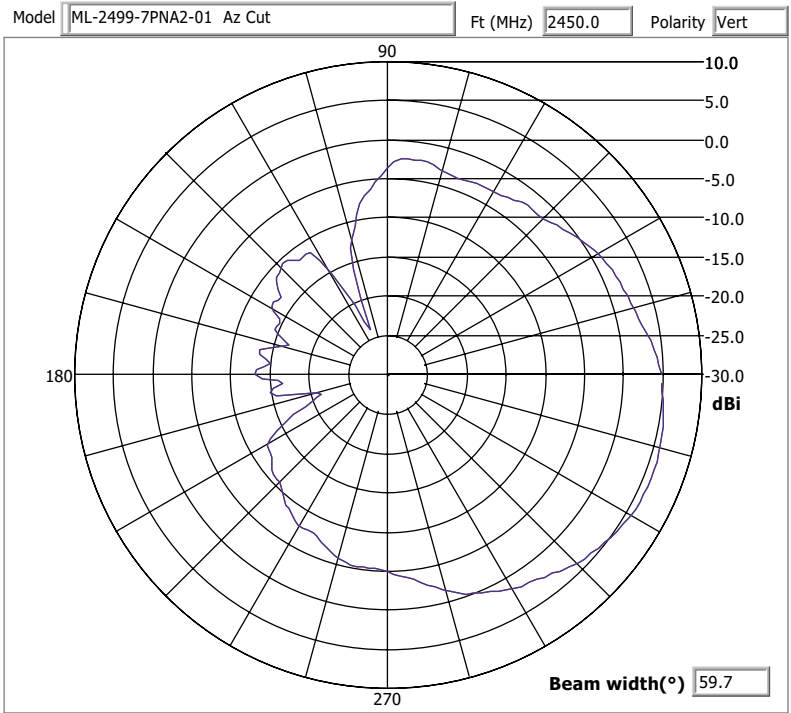

11/12/2003 2:50:29 PM

Azimuth Cut

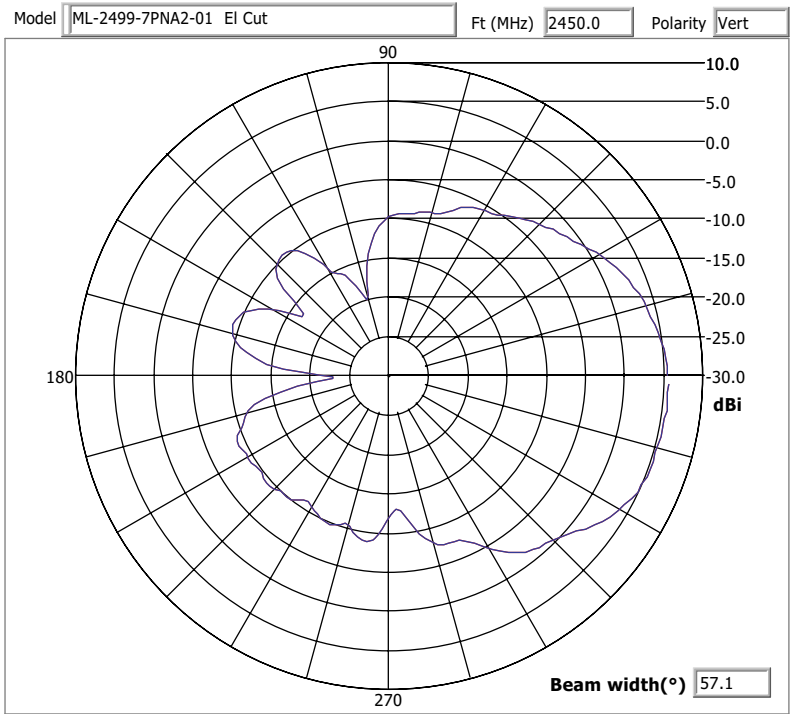

11/12/2003 2:53:26 PM

Elevation Cut

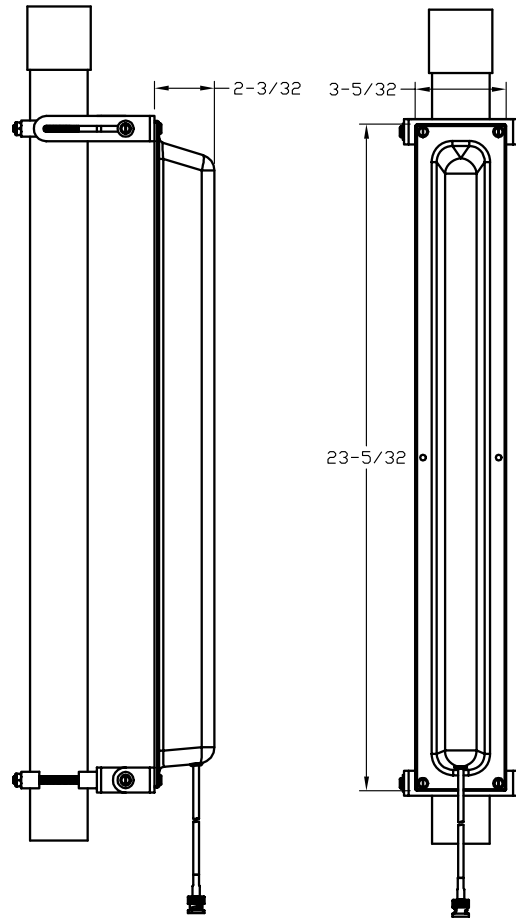
3.1.3 ML-2499-11PNA2-01R Outdoor 97° Sector Panel: RP-BNC Male

<i>Type</i>	Panel
<i>Frequency</i>	2400-1500 MHz
<i>Gain (dBi)</i>	8.5
<i>Polarization</i>	Linear, Vertical
<i>Azimuth</i>	3dB Beamwidth: 97°
<i>Elevation</i>	3dB Beamwidth: 14°
<i>Cable Length (in.)</i>	96
<i>Cable Type</i>	RG-58 Ultralink
<i>Connector Type</i>	RP-BNC Male
<i>Weight</i>	1.5 lb
<i>Plenum Antenna</i>	No
<i>Plenum Cable</i>	Yes
<i>Outdoor Rated</i>	Yes

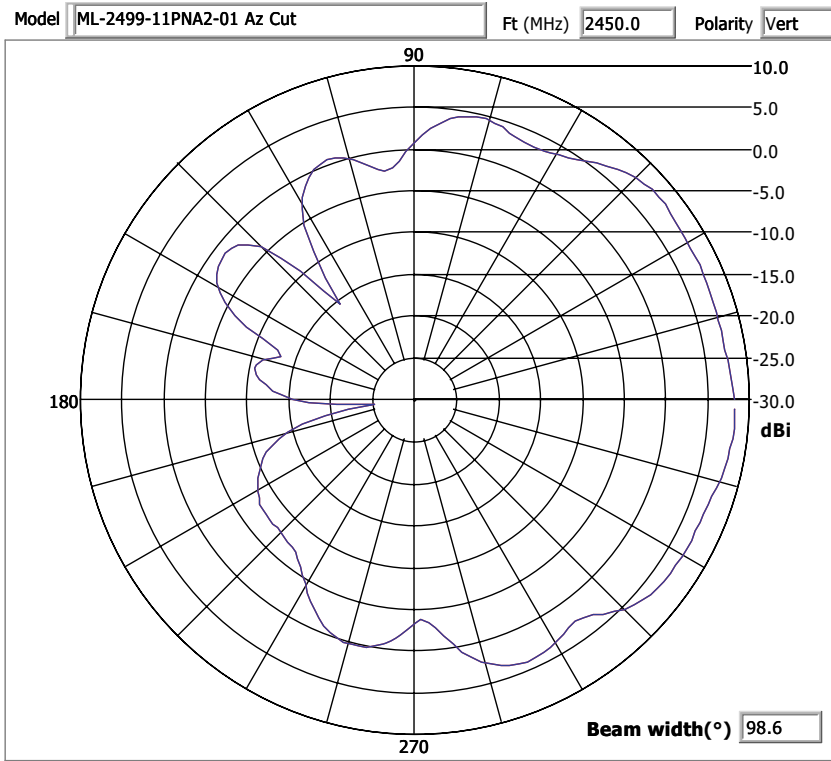

Azimuth Pattern

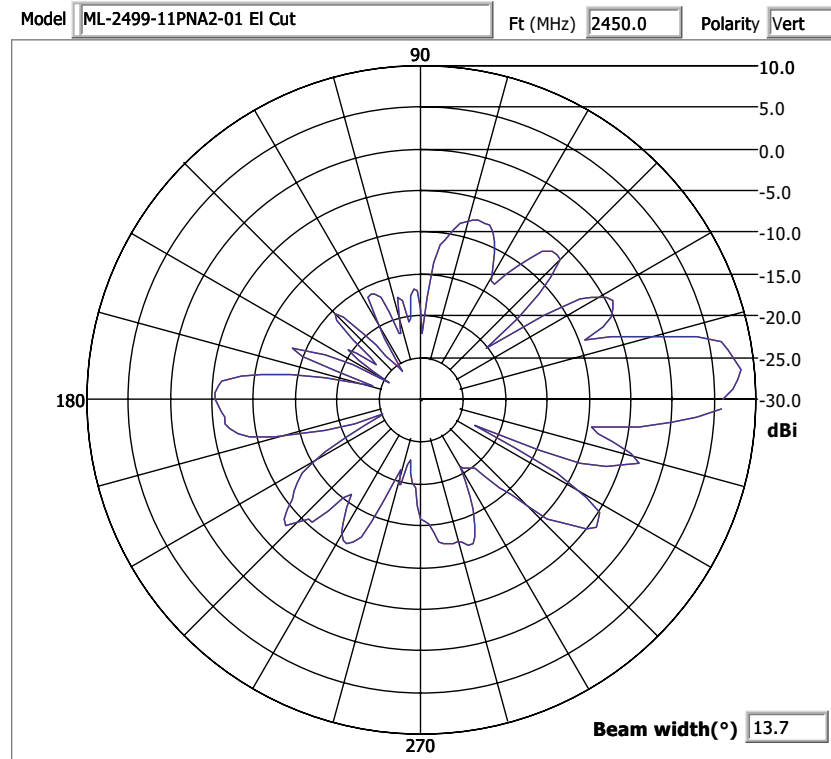

Elevation Pattern

3.1.4 ML-2499-APA2-01R Indoor Rubber Flex, Elbow Joint Dipole: RP-BNC Male

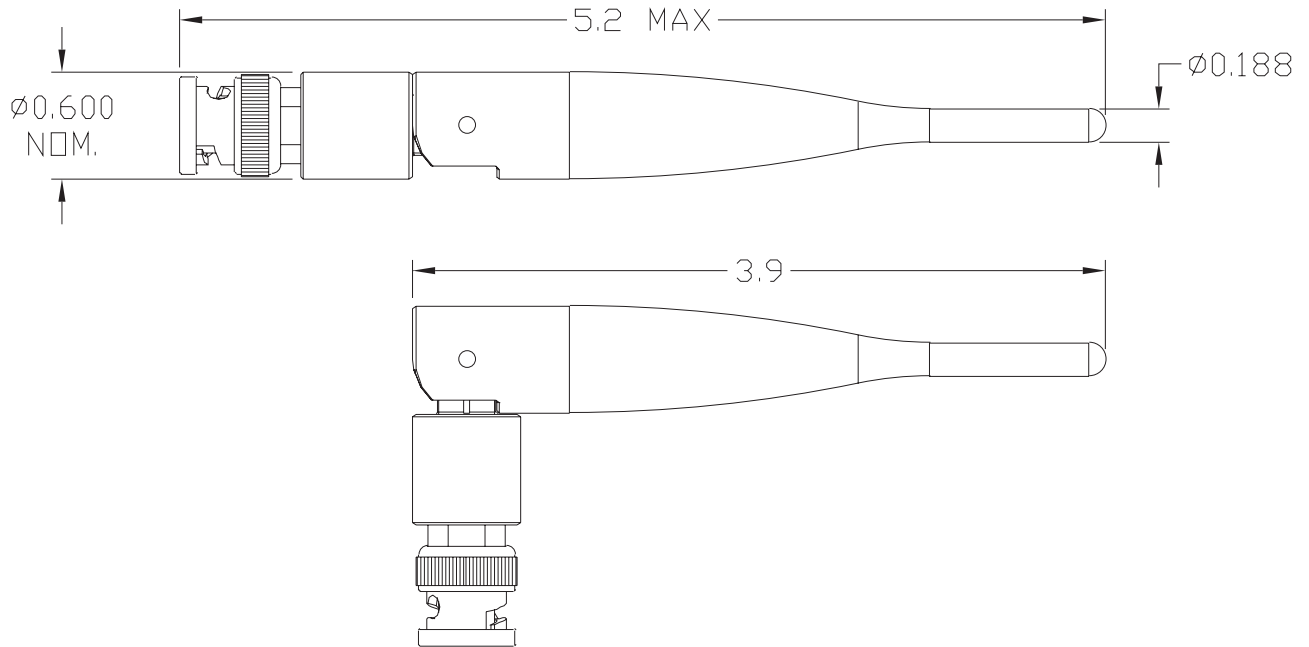

Type	Dipole
Frequency	2400-2500 MHz
Gain (dBi)	2
Polarization	Linear, Vertical
Azimuth	3dB Beamwidth: 360°
Elevation	3dB Beamwidth: 60°
Cable Length (in.)	0
Cable Type	N/A
Connector Type	RP-BNC Male
Weight	0.075 lbs
Plenum Antenna	No
Plenum Cable	N/A
Outdoor Rated	No

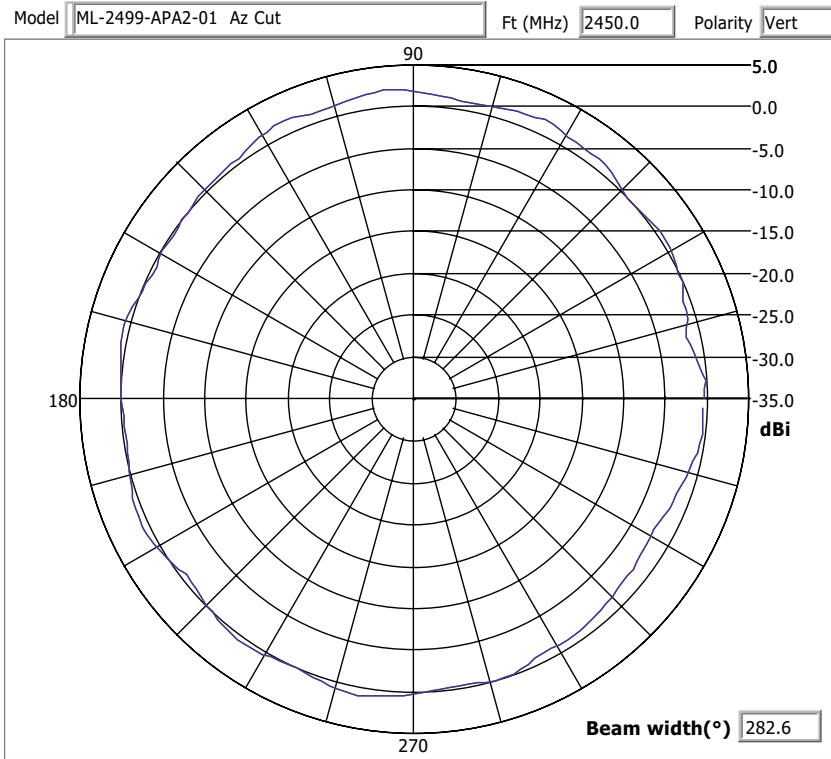

Azimuth Pattern

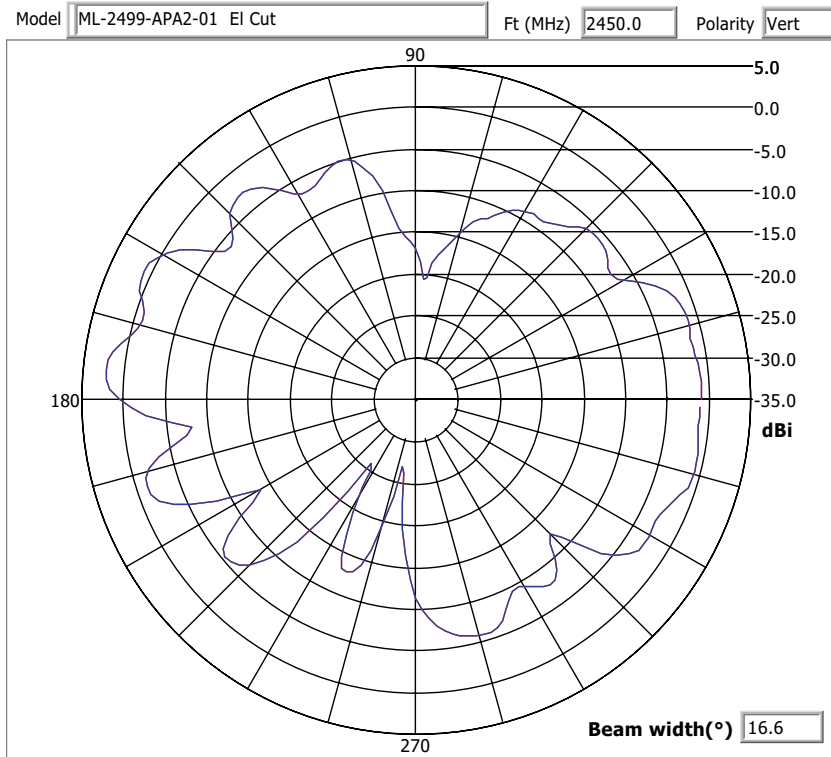

Elevation Pattern

3.1.5 ML-2499-BPDA1-01R Outdoor 10° High-Gain Dish: 20.5 N Female

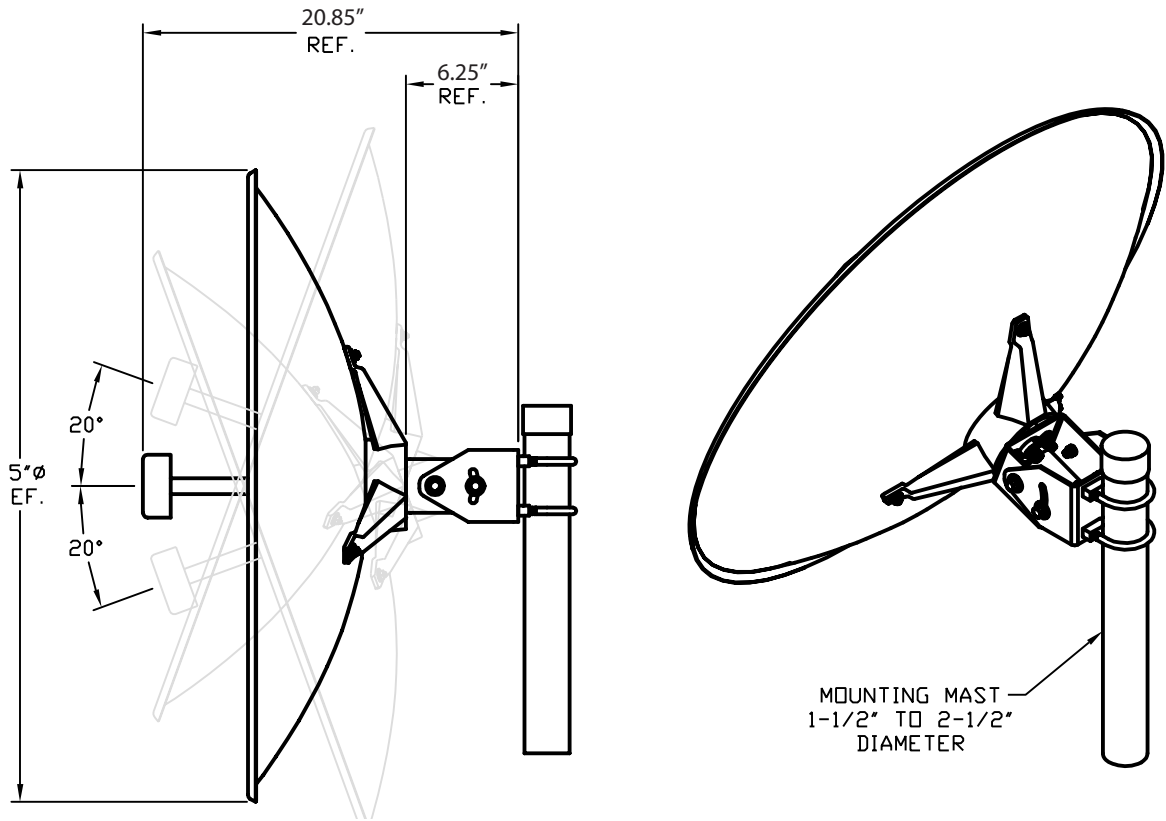

Type	Parabolic Dish
Frequency	2400-2500 MHz
Gain (dBi)	23.5
Net Gain (dBi)	20.5 (minimum cable configuration)
Cable Loss (dB)	3 (minimum cable configuration)
Polarization	Linear, Vertical
Azimuth	3dB Beamwidth: 10°
Elevation	3dB Beamwidth: 11°
Cable Length (in.)	Use minimum configuration (or more)
Cable Type	Varies per cable configuration
Connector Type	Type N Female
Weight	13 lb
Plenum Antenna	N/A
Plenum Cable	N/A
Outdoor Rated	Yes

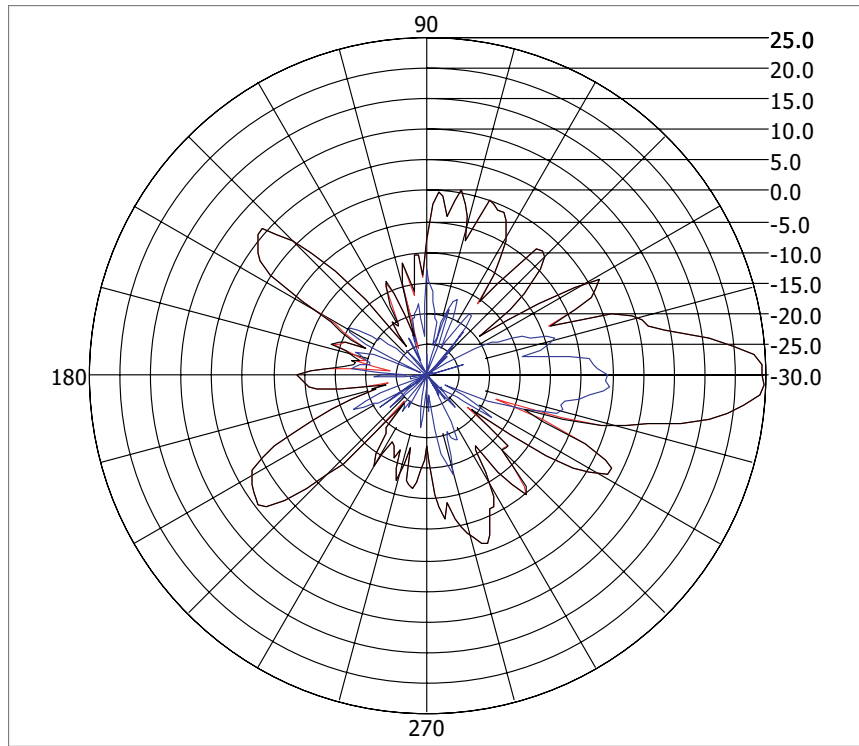

Beam width(°) 11.2

Azimuth Pattern

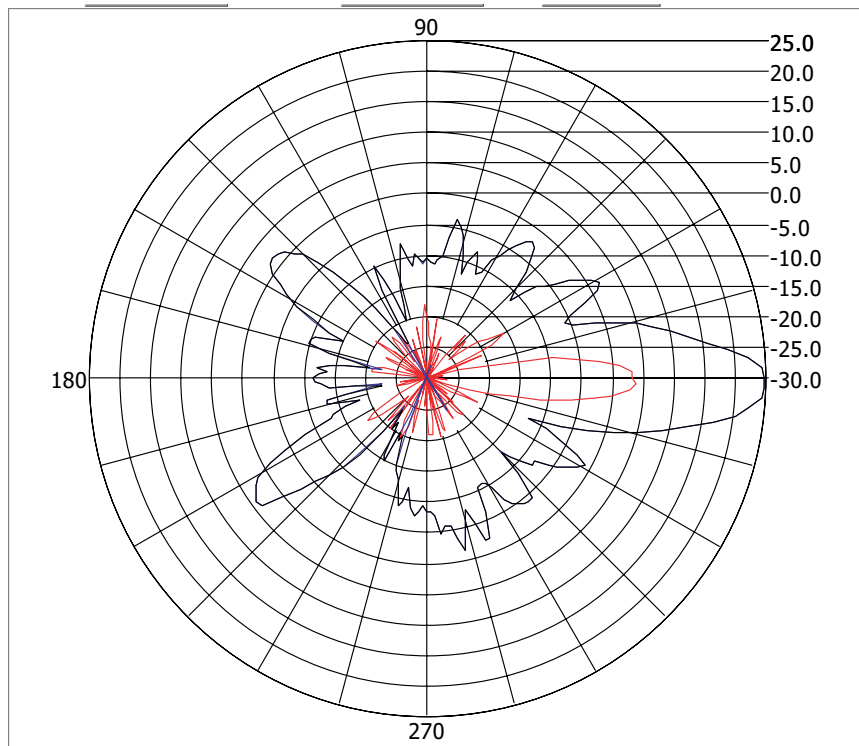

Elevation Pattern

3.1.6 ML-2499-BPNA3-01R Outdoor 35° High-Gain Directional Panel: Type N - Female

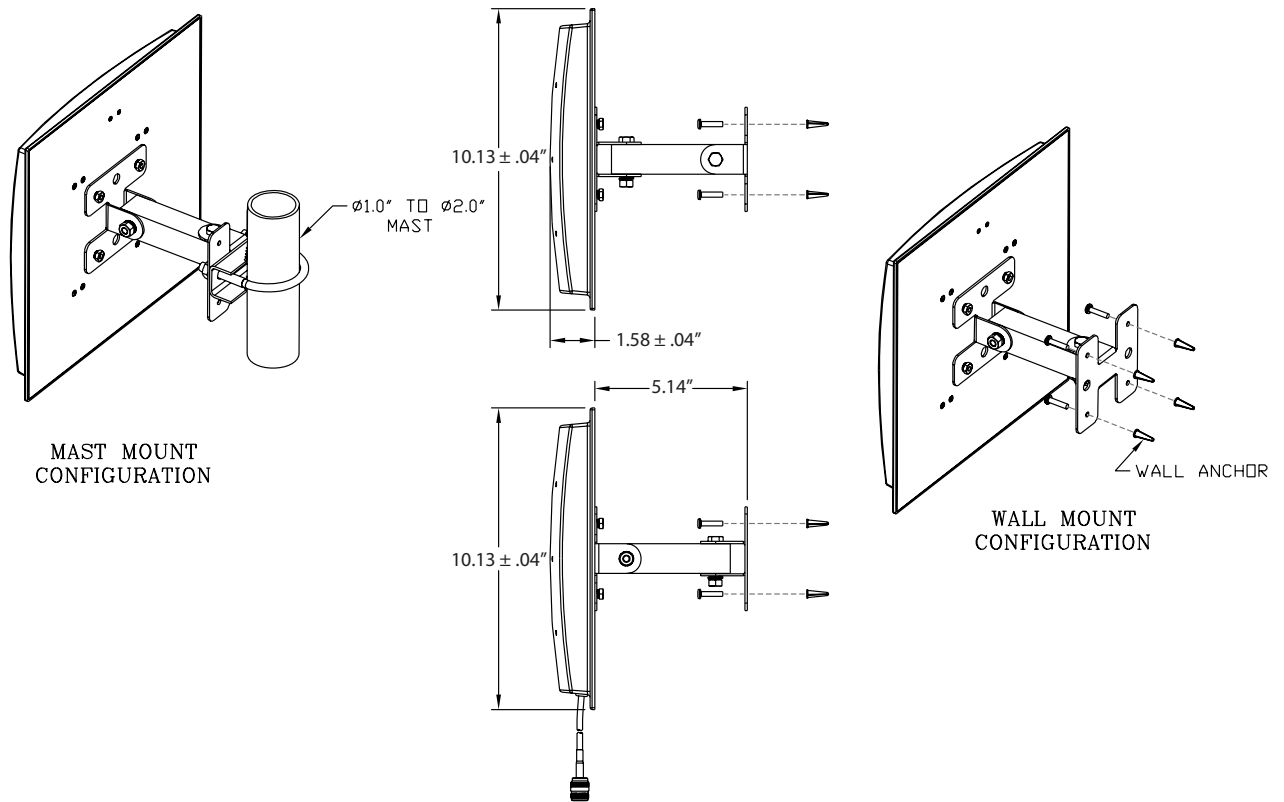

Type	Panel (Outdoor)
Frequency	2400-2500 MHz
Gain (dBi)	13.9
Net Gain (dBi)	10.9 (minimum cable configuration)
Cable Loss (dB)	3 (minimum cable configuration)
Polarization	Linear, Vertical
Azimuth	3dB Beamwidth: 35°
Elevation	3dB Beamwidth: 28°
Cable Length (in.)	Use minimum configuration (or more)
Cable Type	Varies per cable configuration
Connector Type	Type N Female
Weight	1.5 lb
Plenum Antenna	N/A
Plenum Cable	N/A
Outdoor Rated	Yes

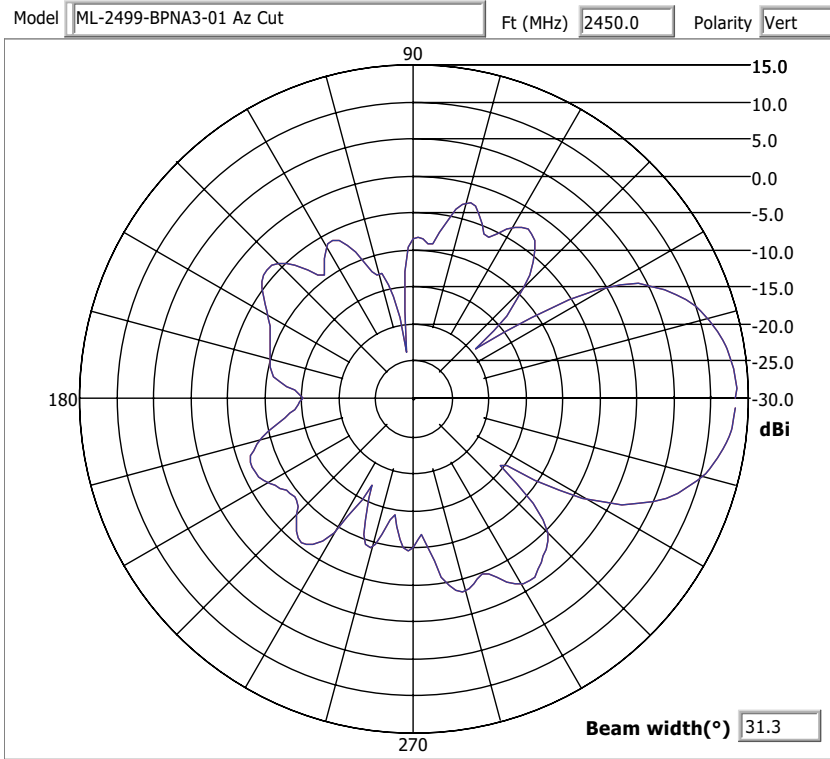

11/12/2003 4:49:00 PM

Azimuth Pattern

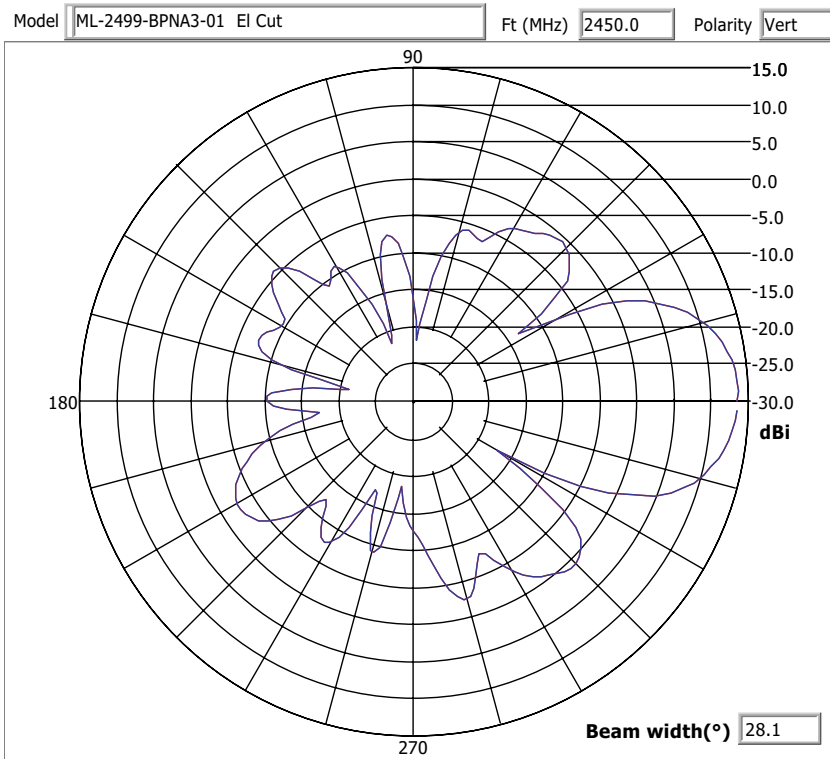

11/12/2003 4:44:40 PM

Elevation Pattern

3.1.7 ML-2499-BYGA2-01R Outdoor 35° High-Gain Directional Yagi: N Female

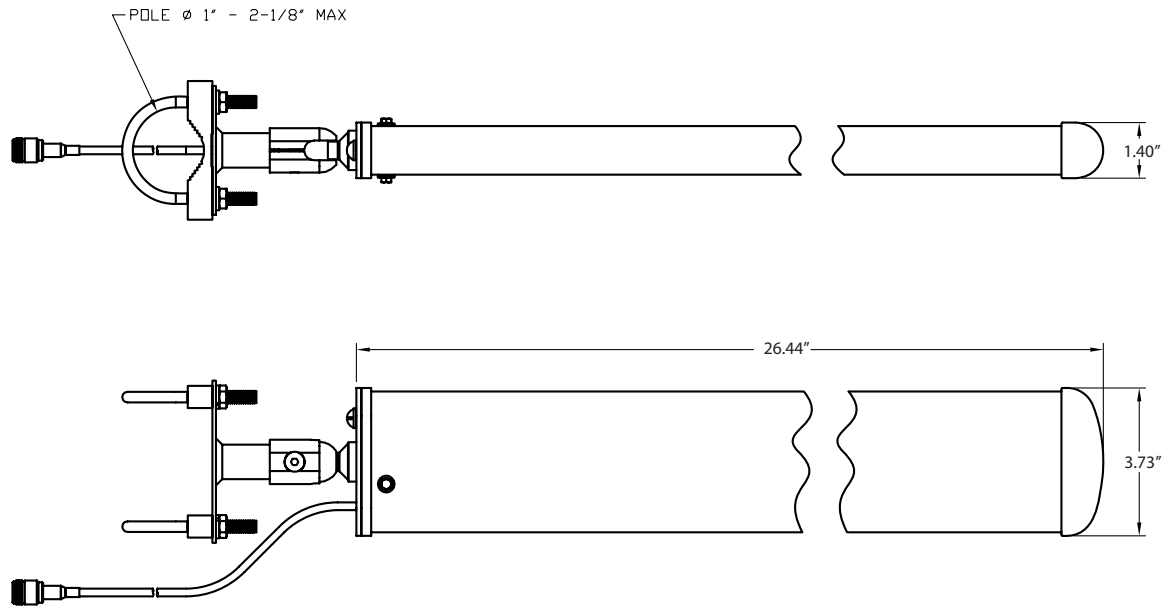

Type	Yagi (Outdoor)
Frequency	2400-2500 MHz
Gain (dBi)	14.1
Net Gain (dBi)	11.1 (minimum cable configuration)
Cable Loss (dB)	3 (minimum cable configuration)
Polarization	Linear, Vertical
Azimuth	3dB Beamwidth: 35°
Elevation	3dB Beamwidth: 30°
Cable Length (in.)	12
Cable Type	Varies per the cable configuration used
Connector Type	Type N - Female
Power	50 W
Weight	1.25 lb

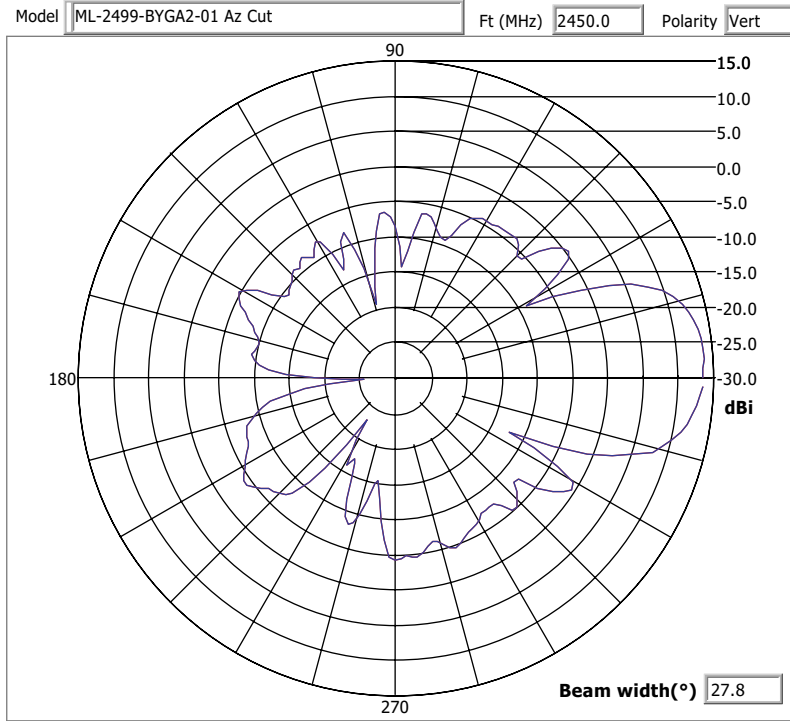

11/12/2003 5:58:10 PM

Azimuth Pattern

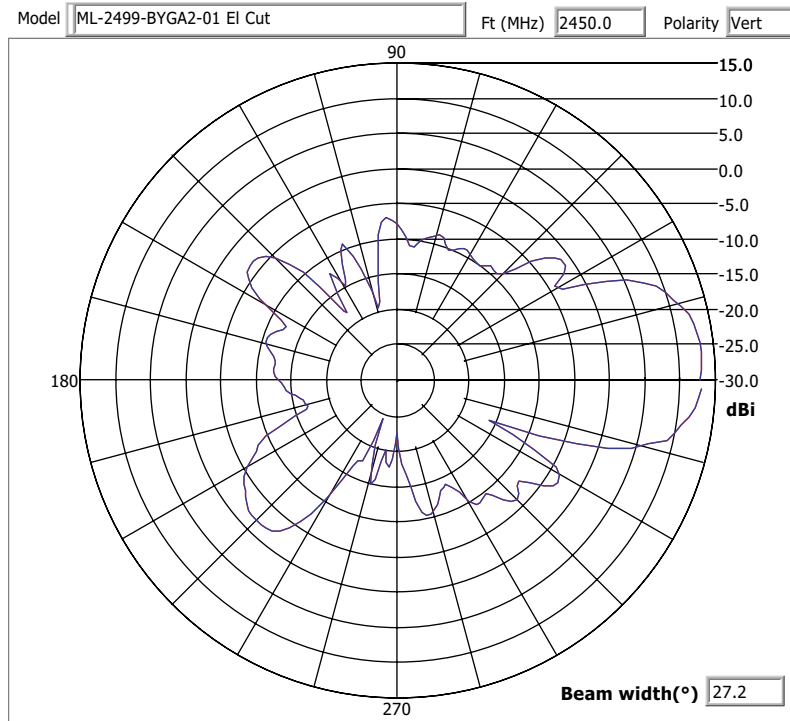

11/12/2003 6:00:02 PM

Elevation Pattern

3.1.8 ML-2499-HPA3-01R High Performance Omni-Directional "Pipe" Antenna: RP-BNC Male

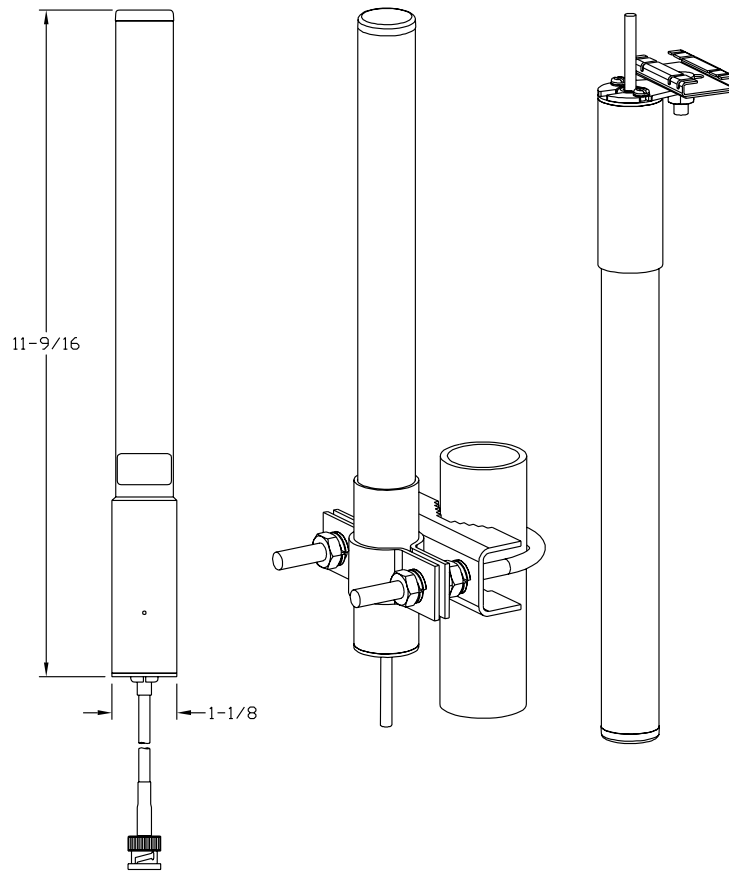

<i>Type</i>	Dipole Array
<i>Frequency</i>	2400-2500 MHz
<i>Gain (dBi)</i>	3.3
<i>Polarization</i>	Linear, Vertical
<i>Azimuth</i>	3dB Beamwidth: 360°
<i>Elevation</i>	3dB Beamwidth: 31°
<i>Cable Length (in.)</i>	48
<i>Cable Type</i>	RG-58 Ultralink
<i>Connector Type</i>	RP-BNC Male
<i>Weight</i>	0.3 lb
<i>Plenum Antenna</i>	No
<i>Plenum Cable</i>	Yes
<i>Outdoor Rated</i>	Yes (in a cable down orientation)

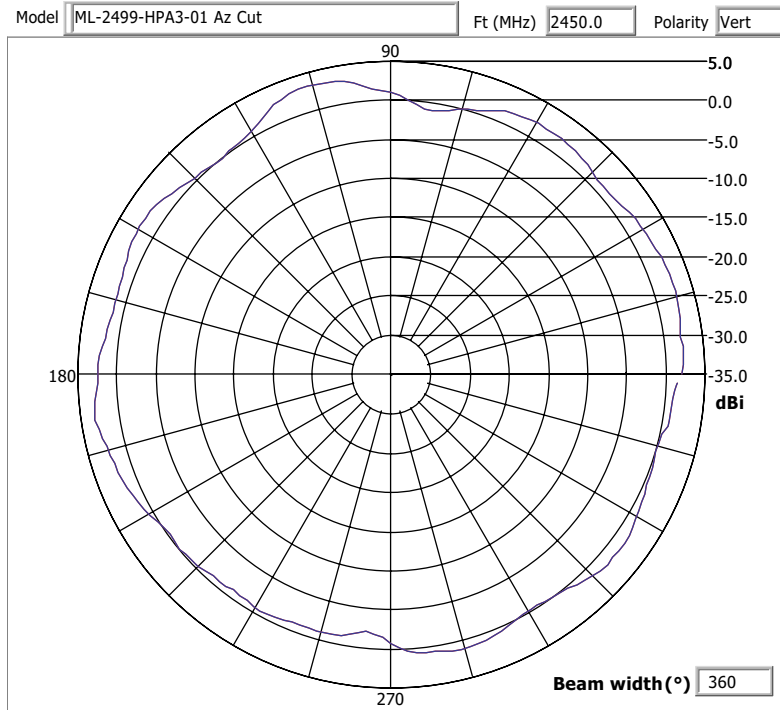

11/12/2003 6:22:13 PM

Azimuth Pattern

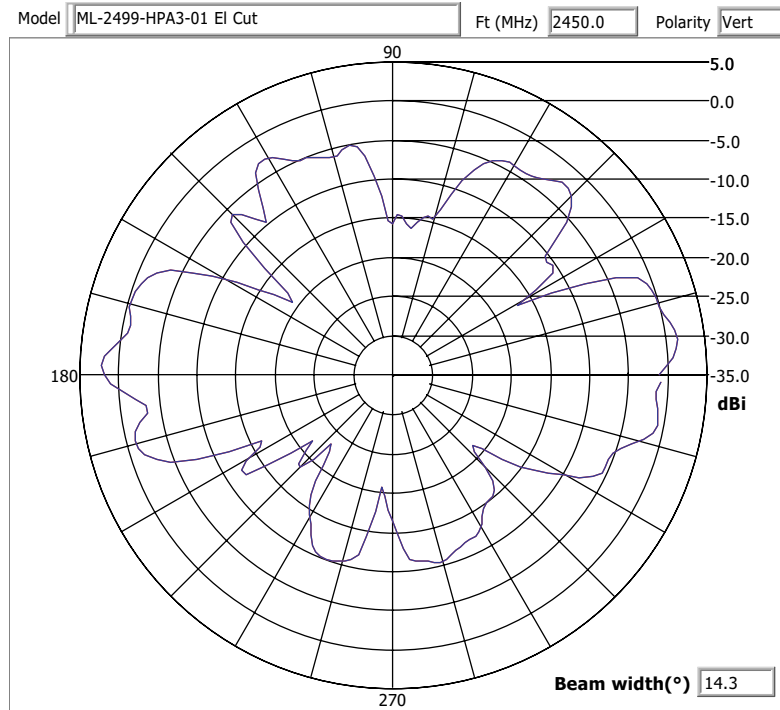

11/12/2003 6:19:10 PM

Elevation Pattern

3.1.9 ML-2499-PNAHD-01R Indoor 55° Directional Panel: RP-BNC Male

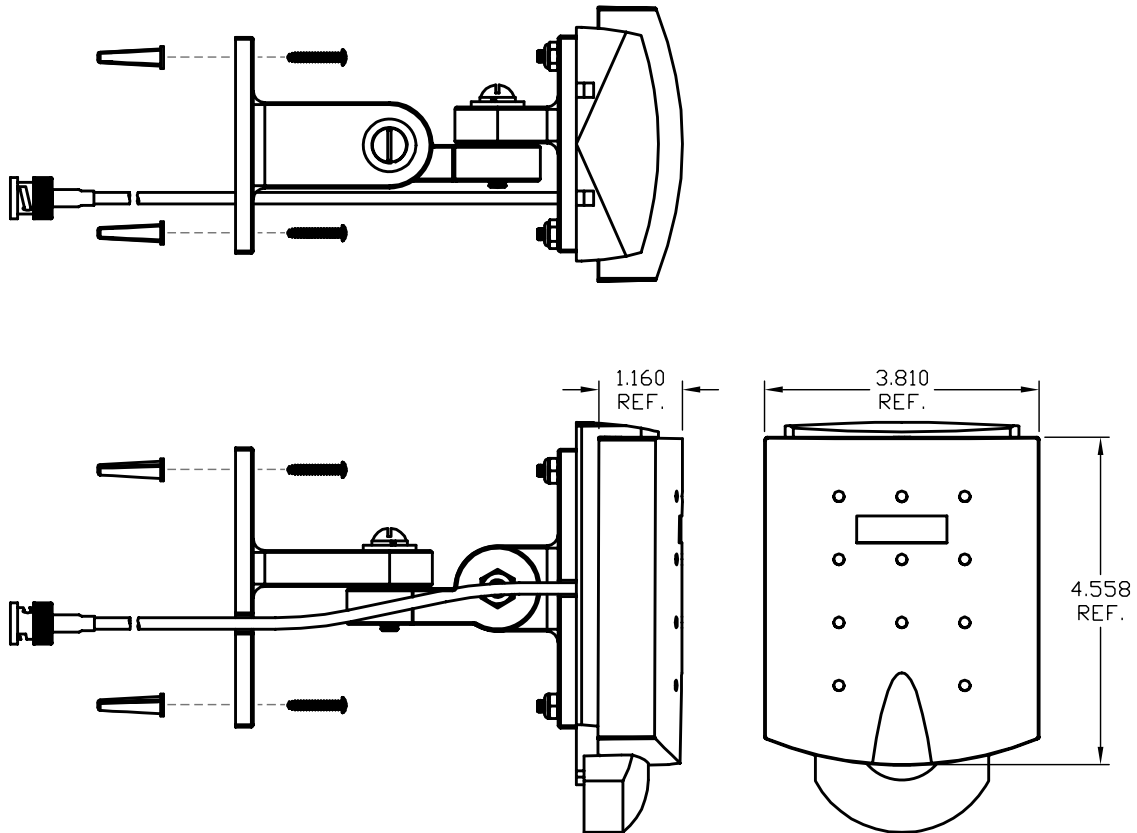

Type	Panel
Frequency	2400-2500 Mhz
Gain (dBi)	6.3
Polarization	Linear, Vertical
Azimuth	3dB Beamwidth: 55°
Elevation	3dB Beamwidth: 56°
Cable Length (in.)	48
Cable Type	RG-58 Ultralink
Connector Type	RP-BNC Male
Weight	0.5 lb
Plenum Antenna	No
Plenum Cable	Yes
Outdoor Rated	No

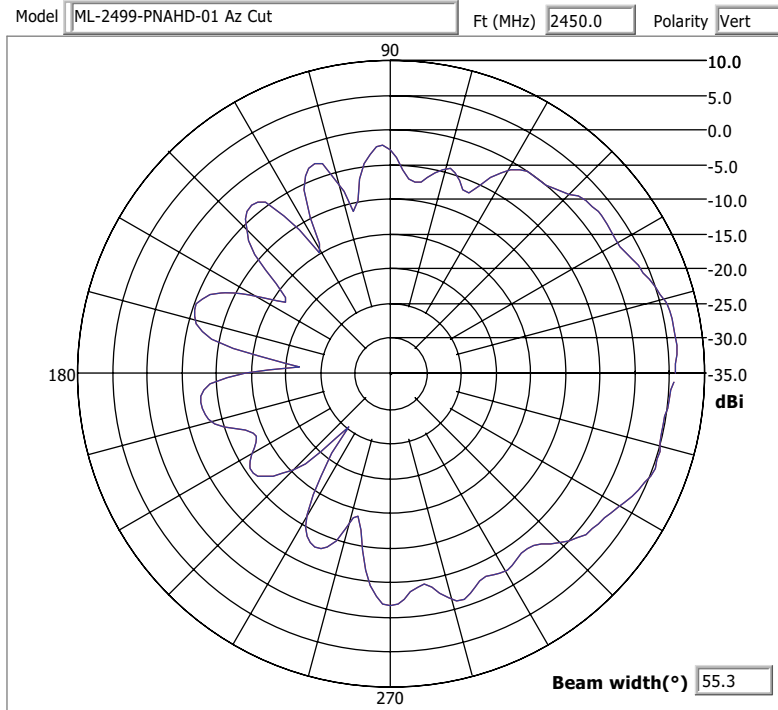

11/12/2003 6:41:17 PM

Azimuth Pattern

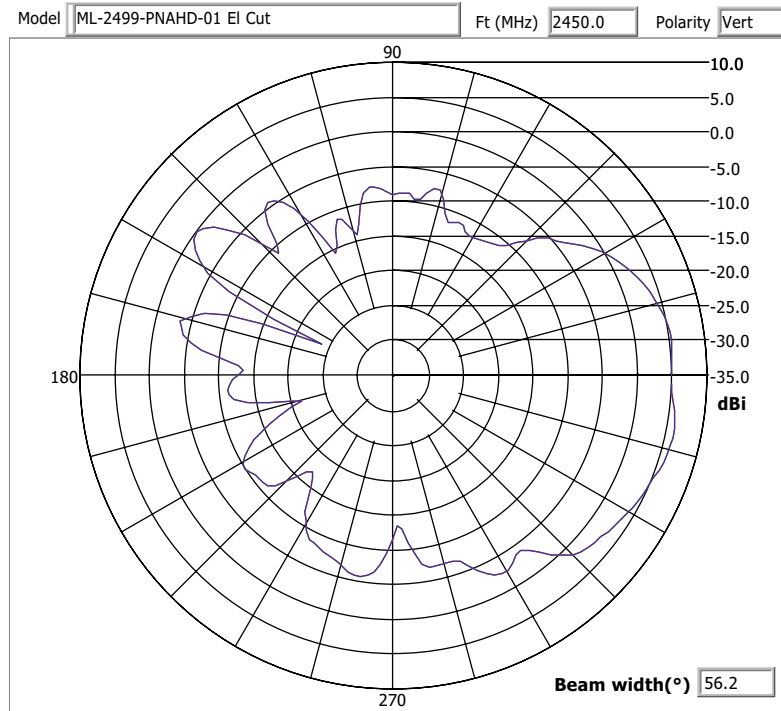

11/12/2003 6:44:37 PM

Elevation Pattern

3.1.10 ML-2499-SD3-01R Low Profile Ceiling/Surface Mount Omni-Directional Patch: RP-BNC Male

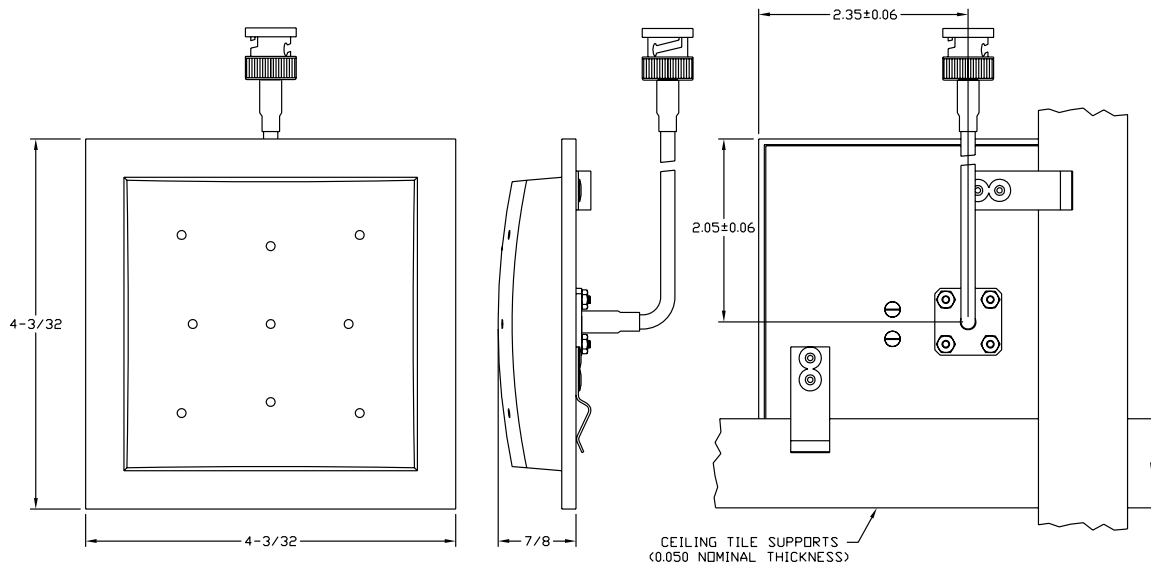

Type	Patch (ceiling mount)
Frequency	2400-2500 MHz
Gain (dBi)	3.5
Polarization	Linear, Vertical
Azimuth	3dB Beamwidth: 360°
Elevation	3dB Beamwidth: 52°
Cable Length (in.)	48
Cable Type	RG-58 Ultralink
Connector Type	RP-BNC Male
Weight	0.21 lbs
Plenum Antenna	No
Plenum Cable	Yes
Outdoor Rated	No

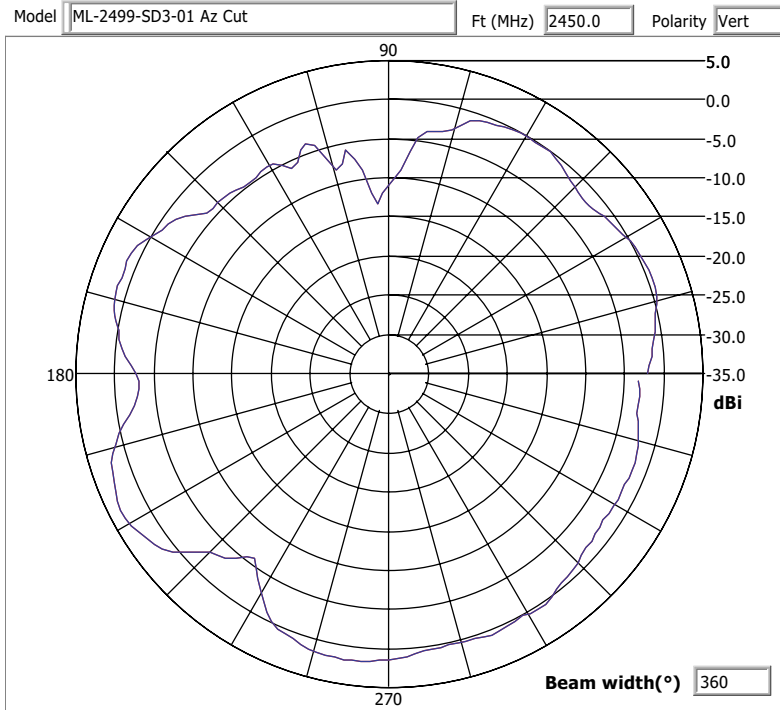

11/24/2003 4:14:27 PM

Azimuth Pattern

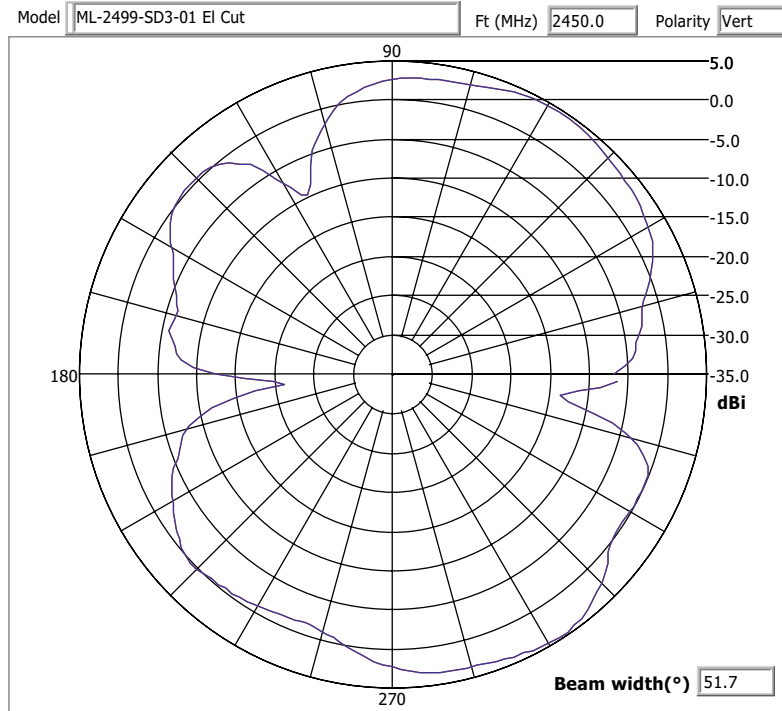

11/12/2003 6:54:30 PM

Elevation Pattern

3.1.11 ML-2499-FHPA5-01R Omni-Directional "Pipe" Antenna: N Male Connector



ML-2499-FHPA5-01R

<i>Type</i>	Dipole Array
<i>Frequency</i>	2400-2500 MHz
<i>Gain (dBi)</i>	5
<i>Polarization</i>	Linear, Vertical
<i>Azimuth</i>	3dB Beamwidth: 360°
<i>Elevation</i>	3dB Beamwidth: 25°
<i>Cable Length (in.)</i>	N/A
<i>Cable Type</i>	N/A
<i>Connector Type</i>	Type N Male
<i>Weight</i>	0.7 lb
<i>Plenum Antenna</i>	No
<i>Plenum Cable</i>	N/A
<i>Outdoor Rated</i>	Yes

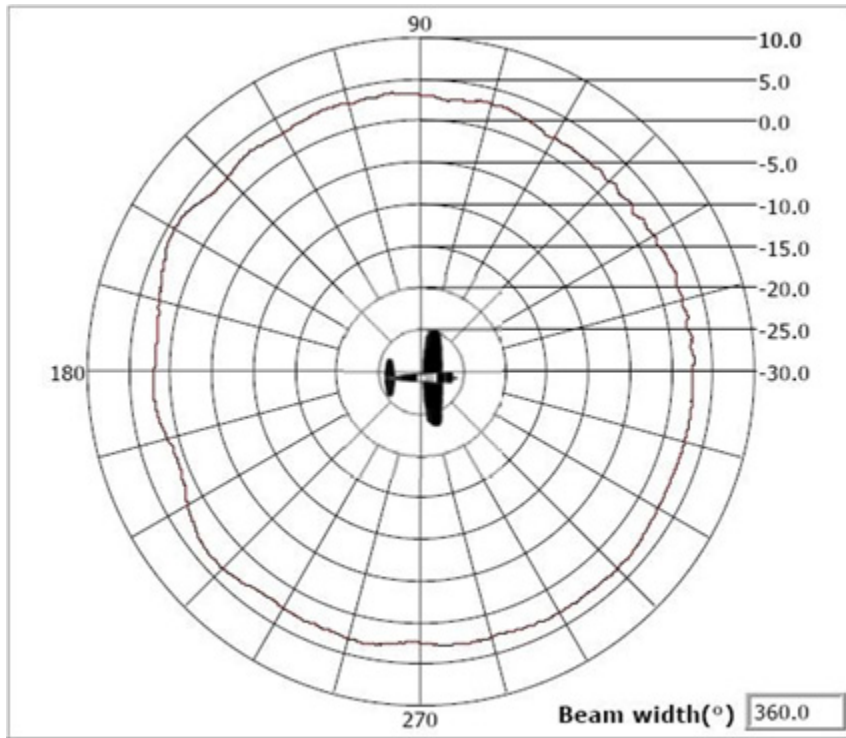

Azimuth Pattern 2450 MHz

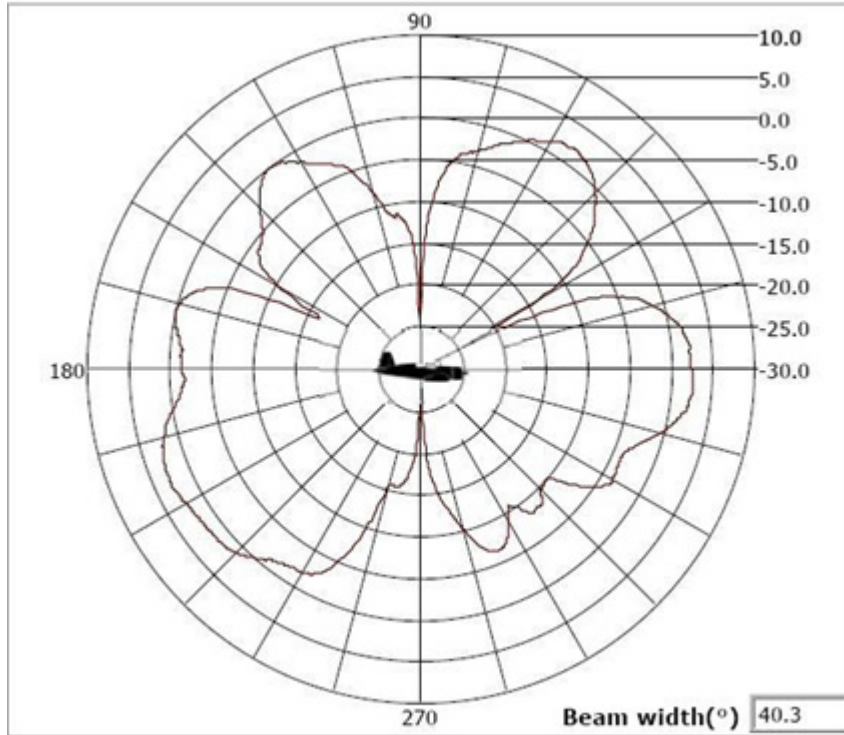

Elevation Pattern 2450 MHz

3.1.12 ML-2499-FHPA9-01R High Performance Fixed Point Dipole: Male Connector



ML-2499-FHPA9-01R

<i>Type</i>	Dipole Array
<i>Frequency</i>	2400-2500 MHz
<i>Gain (dBi)</i>	9
<i>Polarization</i>	Linear, Vertical
<i>Azimuth</i>	3dB Beamwidth: 360°
<i>Elevation</i>	3dB Beamwidth: 14°
<i>Cable Length (in.)</i>	N/A
<i>Cable Type</i>	N/A
<i>Connector Type</i>	Type N Male
<i>Weight</i>	1.1 lb
<i>Plenum Antenna</i>	No
<i>Plenum Cable</i>	N/A
<i>Outdoor Rated</i>	Yes

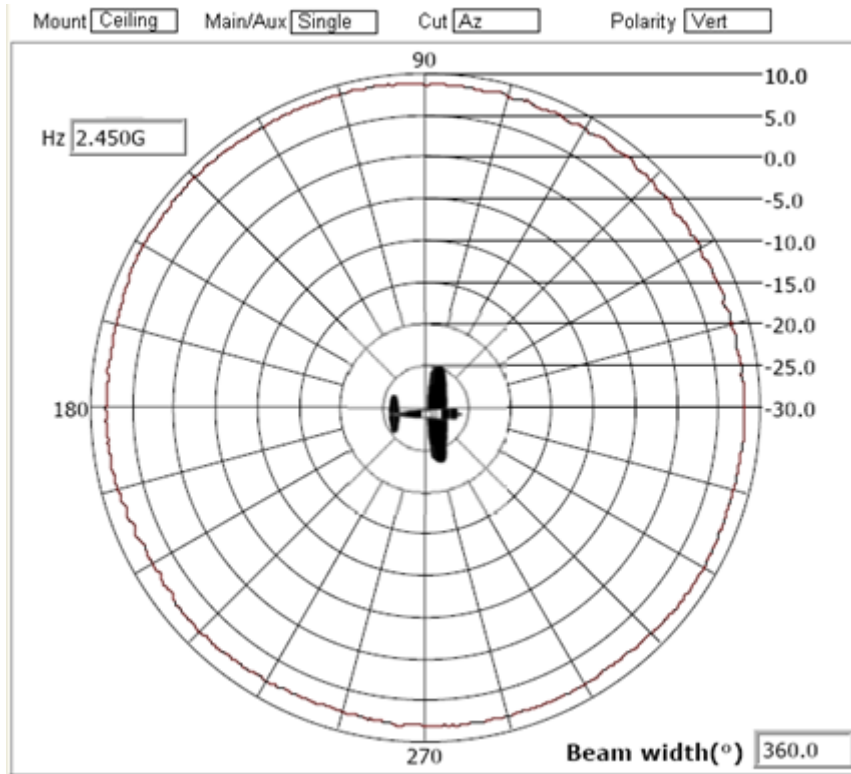

Azimuth Pattern

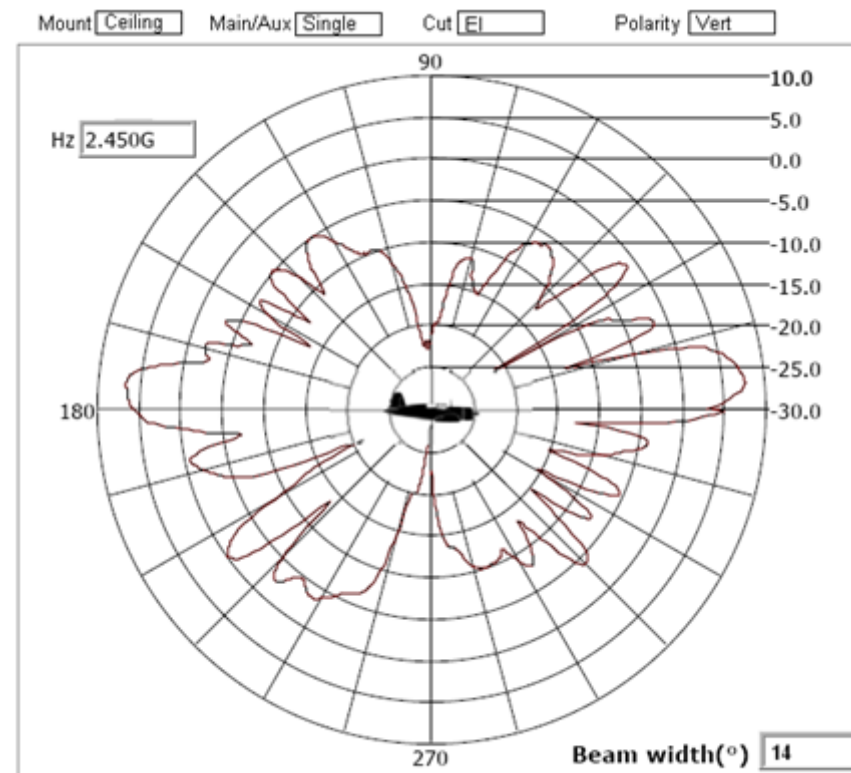

Elevation Pattern

5.2 Ghz Single Band Antenna Suite

4.1 Supported 802.11a/n Antenna Suite

Motorola supports numerous 802.11a/n antennas to suit the requirements of your unique access point or access port deployment. Check the Motorola Web site periodically, as newly supported 802.11a/n antennas will be added to this document as they are released. For more information, go to <http://support.symbol.com/support/product/manuals.do>.

For detailed information on supported 802.11a/n antenna models, refer to:

- *ML-5299-APA1-01R Indoor Rubber Flex Jointed Dipole: RP-SMA Male Connector*
- *ML-5299-HPA1-01R High Performance Omni-Directional Dipole Antenna: RP-SMA Male Connector*
- *ML-5299-PTA1-01R Low Profile Ceiling-Tile Mount Patch: RP-SMA Male Connector*
- *ML-5299-WPNA1-01R Wall Mount Panel Antenna w/Articulating Mount: RP-SMA Male*
- *ML-5299-FHPA10-01R Omni-Directional "Pipe" Antenna: N-Male Connector*
- *ML-5299-FHPA6-01R Omni-Directional "Pipe" Antenna: N-Male Connector*
- *ML-5299-BYGA15-012 Yagi Antenna: N-Female*



NOTE: For examples on how various antenna and connectors are deployed in a 5 GHz AP-5131 installation, see [5 GHz AP-5131 Antenna Connections](#).

4.1.1 ML-5299-APA1-01R Indoor Rubber Flex Jointed Dipole: RP-SMA Male Connector

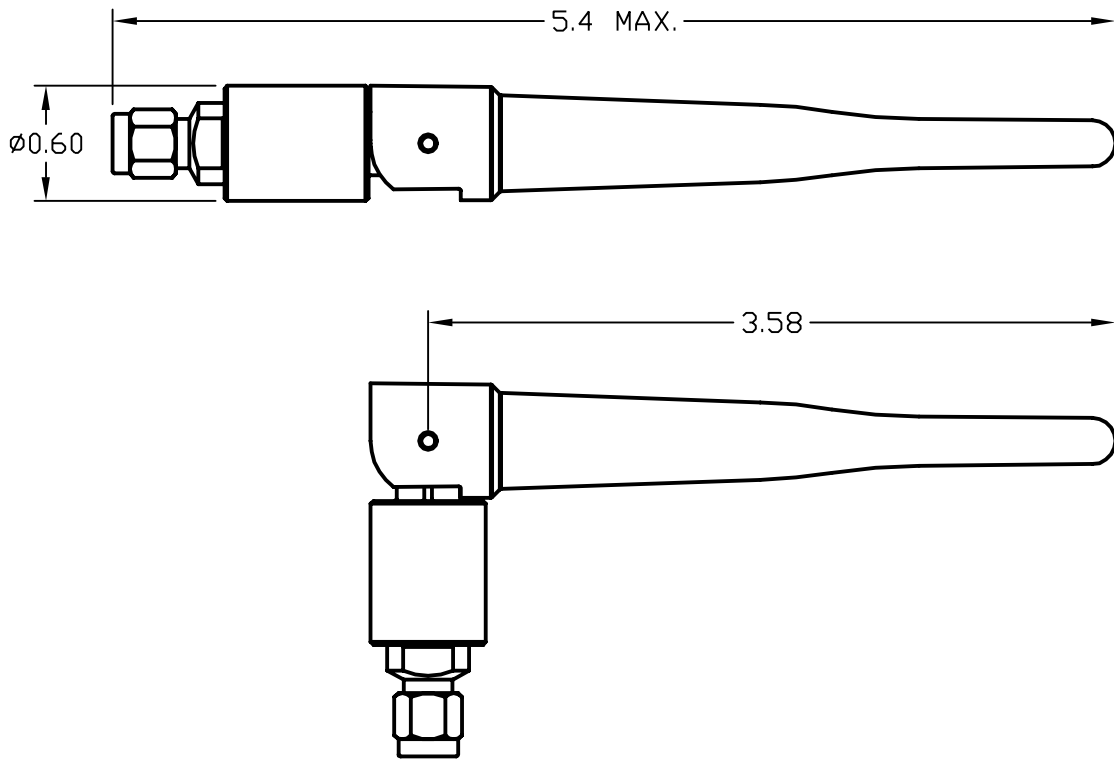

Type	Dipole
Frequency	4900-5875 MHz
Gain (dBi)	2
Polarization	Linear, Vertical
Azimuth	3dB Beamwidth: 360°
Elevation	3dB Beamwidth: 75°
Cable Length (in.)	N/A
Cable Type	N/A
Connector Type	RP-SMA Male
Weight	0.063 lb
Plenum Antenna	No
Plenum Cable	N/A
Outdoor Rated	No

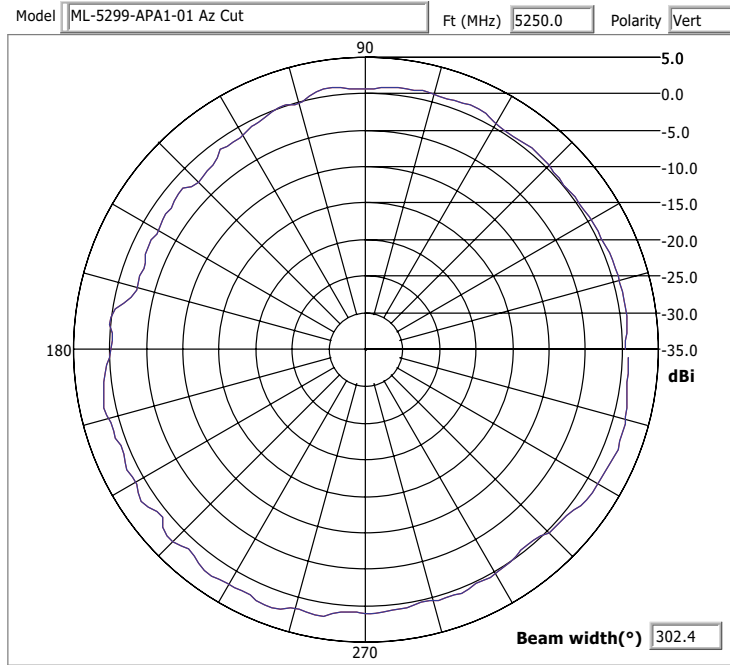

1/7/2004 8:42:26 PM

Azimuth Pattern

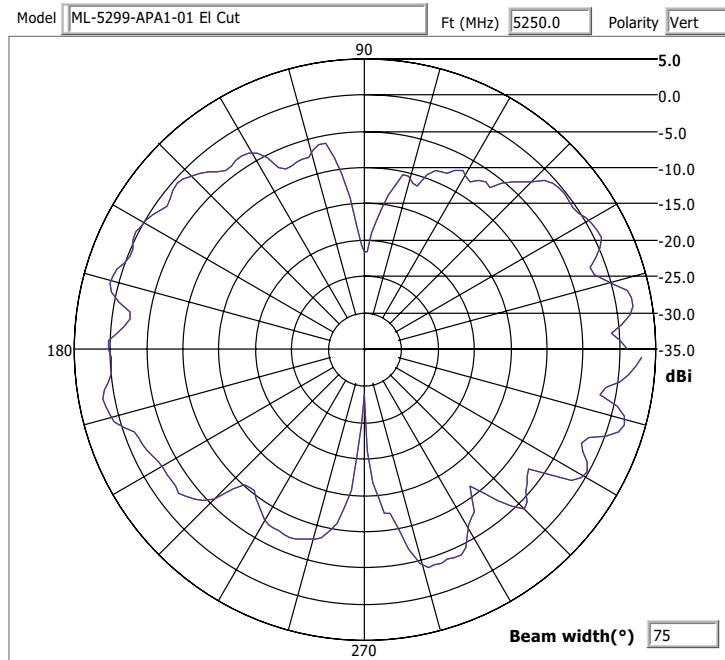

1/7/2004 8:47:57 PM

Elevation Pattern

4.1.2 ML-5299-HPA1-01R High Performance Omni-Directional Dipole Antenna: RP-SMA Male Connector

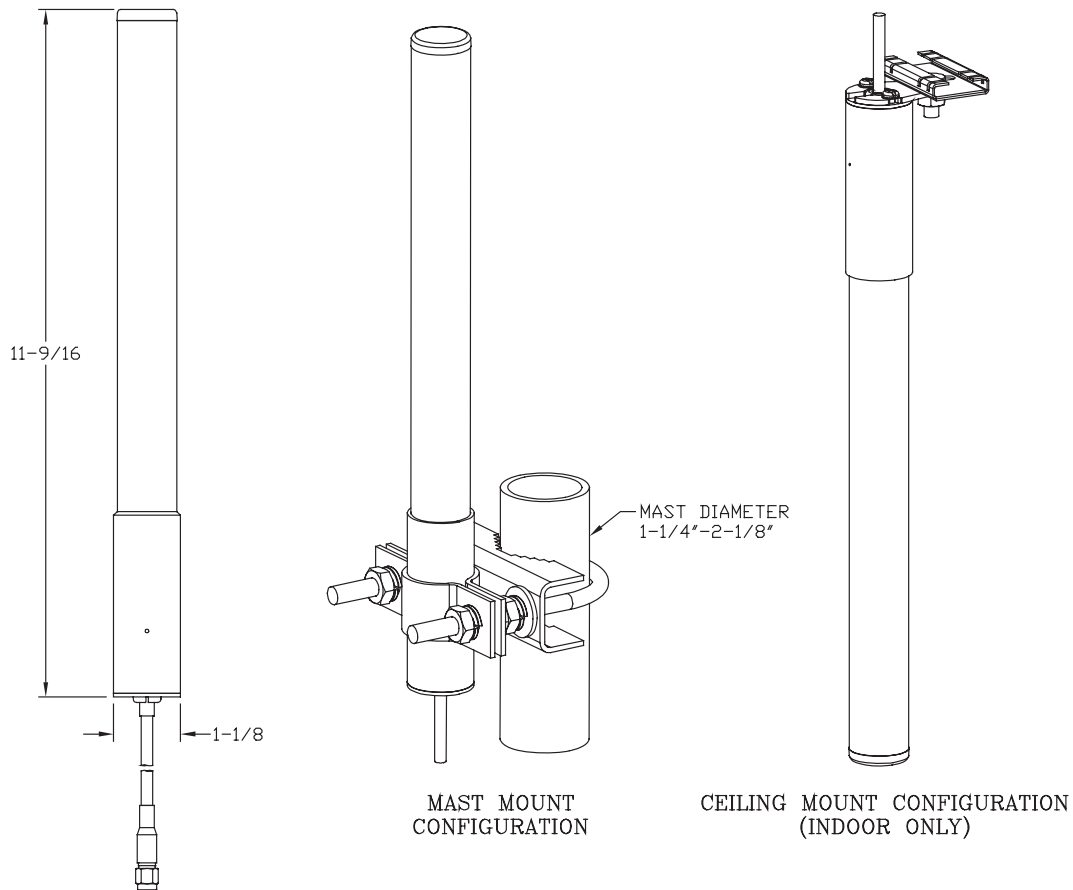

Type	Dipole Array
Frequency	4900-5875 MHz
Gain (dBi)	5
Polarization	Linear, Vertical
Azimuth	3dB Beamwidth: 360°
Elevation	3dB Beamwidth: 17°
Cable Length (in.)	36
Cable Type	LMR195
Connector Type	RP-SMA Male
Weight	0.3 lb.
Plenum Antenna	No
Plenum Cable	Yes
Outdoor Rated	Yes (cable down orientation only)

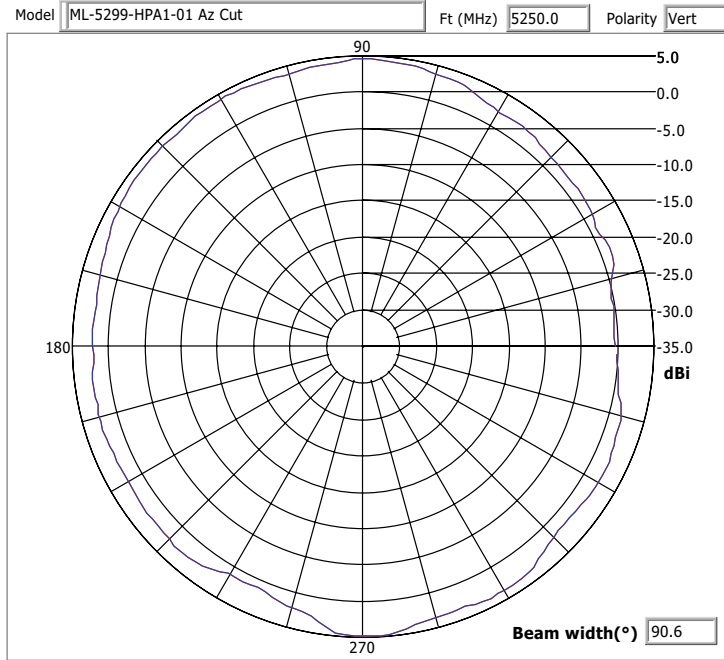

12/15/2003 11:48:02 AM

Azimuth Pattern

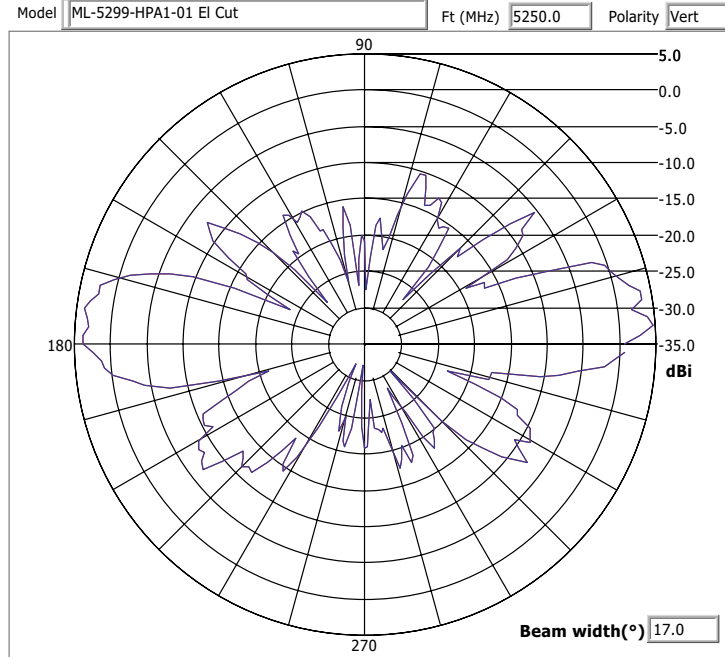

12/15/2003 11:40:30 AM

Elevation Pattern

4.1.3 ML-5299-PTA1-01R Low Profile Ceiling-Tile Mount Patch: RP-SMA Male Connector

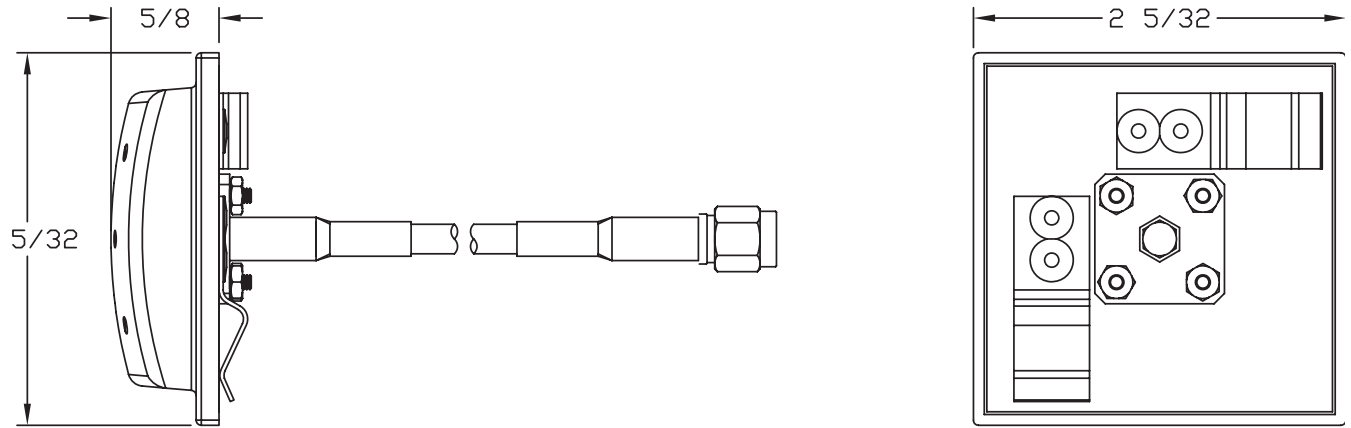

<i>Type</i>	Patch
<i>Frequency</i>	5150-5875 MHz
<i>Gain (dBi)</i>	4.6
<i>Polarization</i>	Linear, Vertical
<i>Azimuth</i>	3dB Beamwidth: 360°
<i>Elevation</i>	3dB Beamwidth: 45°
<i>Cable Length (in.)</i>	36
<i>Cable Type</i>	RG-58
<i>Connector Type</i>	RP-SMA Male
<i>Weight</i>	0.15 lb.
<i>Plenum Antenna</i>	No
<i>Plenum Cable</i>	Yes
<i>Outdoor Rated</i>	No

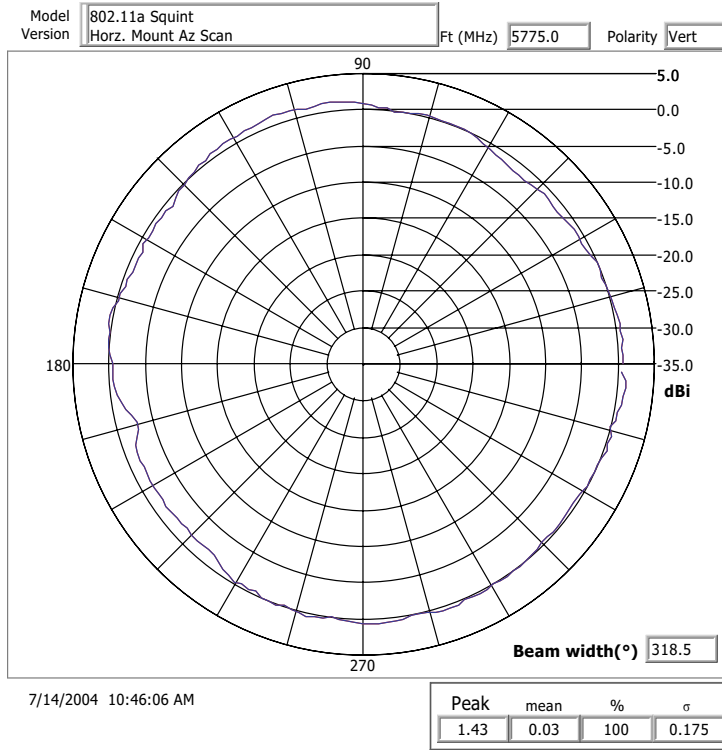

Azimuth Pattern

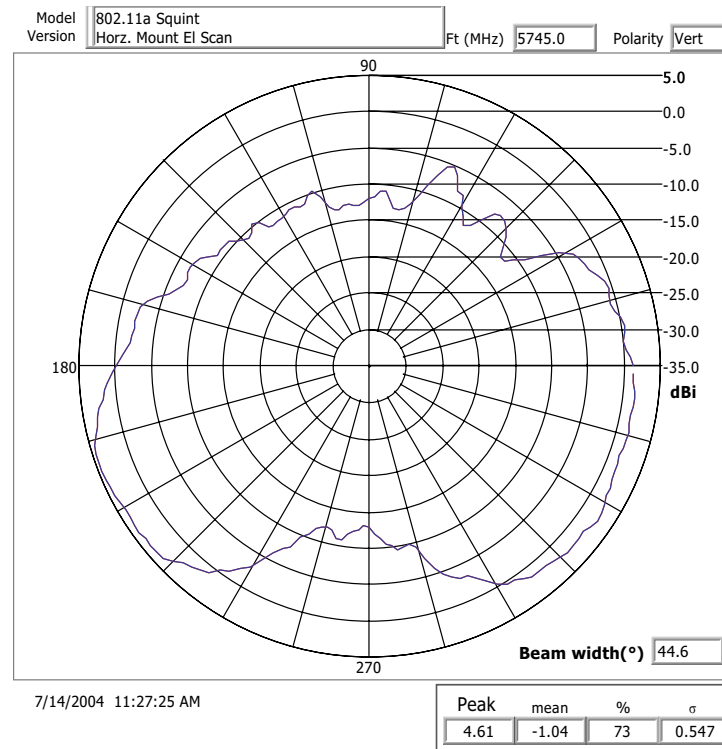

Elevation Pattern

4.1.4 ML-5299-WPNA1-01R Wall Mount Panel Antenna w/Articulating Mount: RP-SMA Male

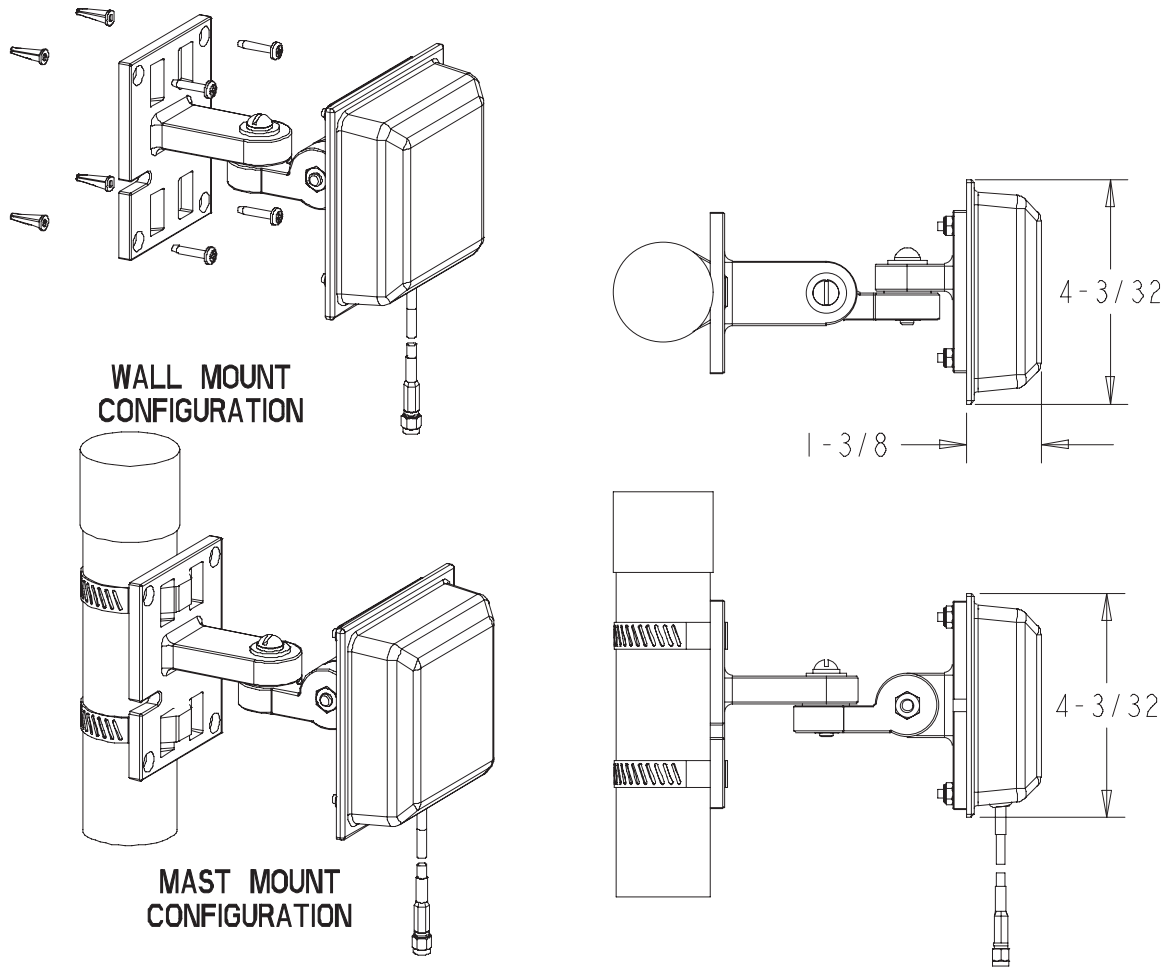

Type	Panel
Frequency	5150-5875 MHz
Gain (dBi)	12.5
Polarization	Linear, Vertical
Azimuth	3dB Beamwidth: 31°
Elevation	3dB Beamwidth: 27°
Cable Length (in.)	36
Cable Type	RG-303
Connector Type	RP-SMA Male
Weight	0.7 lb.
Plenum Antenna	No
Plenum Cable	Yes
Outdoor Rated	Yes

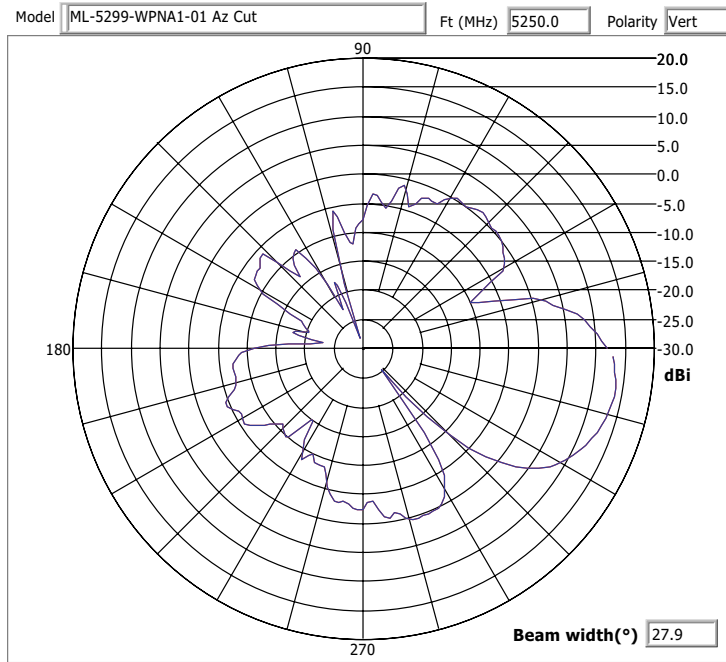

1/5/2004 3:09:33 PM

Azimuth Pattern

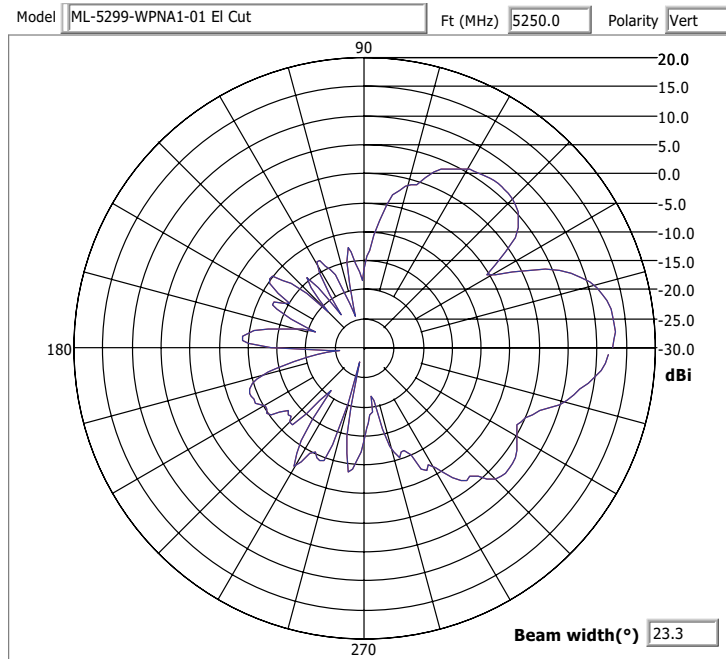

1/5/2004 3:16:21 PM

Elevation Pattern

4.1.5 ML-5299-FHPA10-01R Omni-Directional "Pipe" Antenna: N-Male Connector



ML-5299-FHPA10-01R

<i>Type</i>	Dipole Array
<i>Frequency</i>	4900-5850 MHz
<i>Gain (dBi)</i>	10
<i>Polarization</i>	Linear, Vertical
<i>Azimuth</i>	3dB Beamwidth: 360°
<i>Elevation</i>	3dB Beamwidth: 13
<i>Cable Length (in.)</i>	N/A
<i>Cable Type</i>	N/A
<i>Connector Type</i>	Type N Male
<i>Weight</i>	0.37 lb
<i>Plenum Antenna</i>	No
<i>Plenum Cable</i>	N/A
<i>Outdoor Rated</i>	Yes

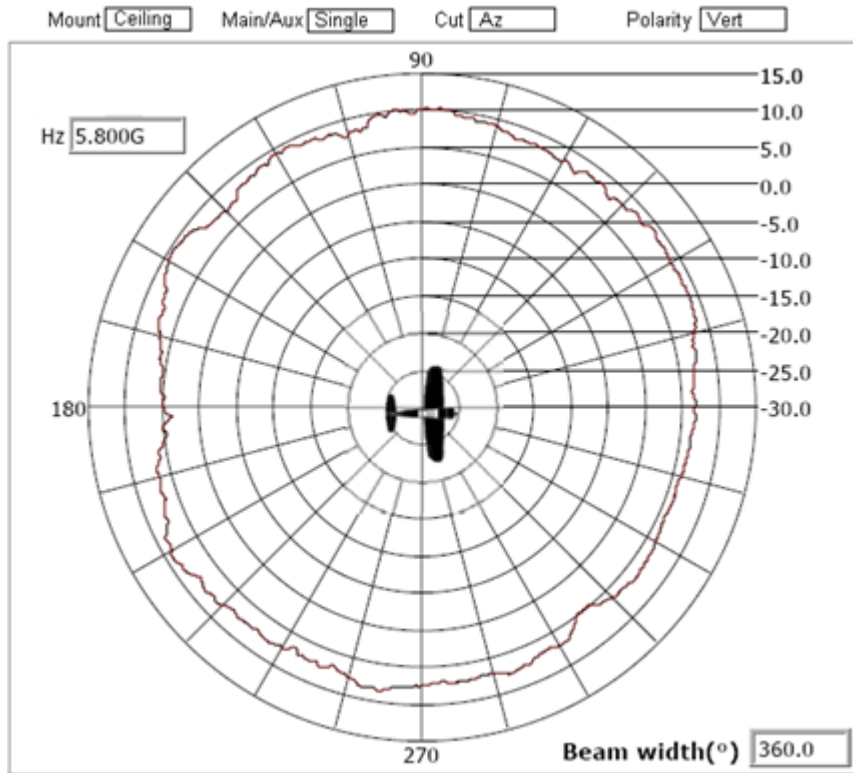

Azimuth Pattern

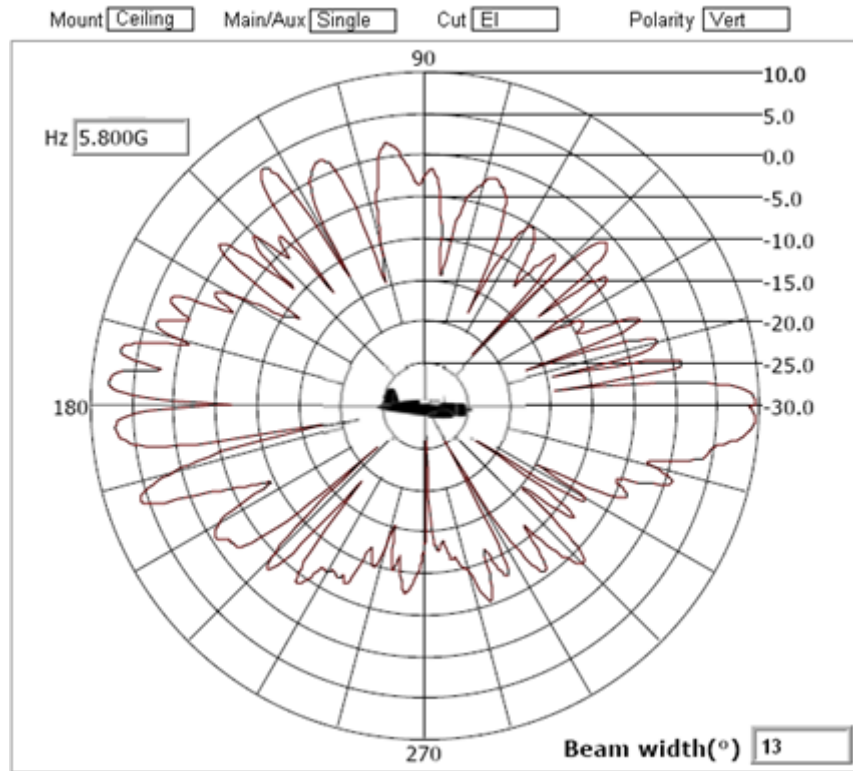

Elevation Pattern

4.1.6 ML-5299-FHPA6-01R Omni-Directional "Pipe" Antenna: N-Male Connector

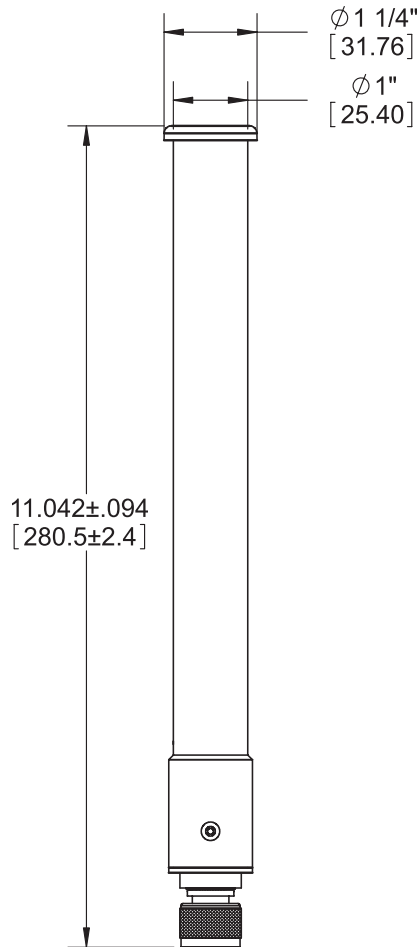

Type	Dipole Array
Frequency	5150-5850
Gain (dBi)	6
Polarization	Linear, Vertical
Azimuth	3dB Beamwidth: 360°
Elevation	3dB Beamwidth: 16°
Cable Length (in.)	N/A
Cable Type	N/A
Connector Type	Type N Male
Weight	0.37 lb
Plenum Antenna	No
Plenum Cable	N/A
Outdoor Rated	Yes

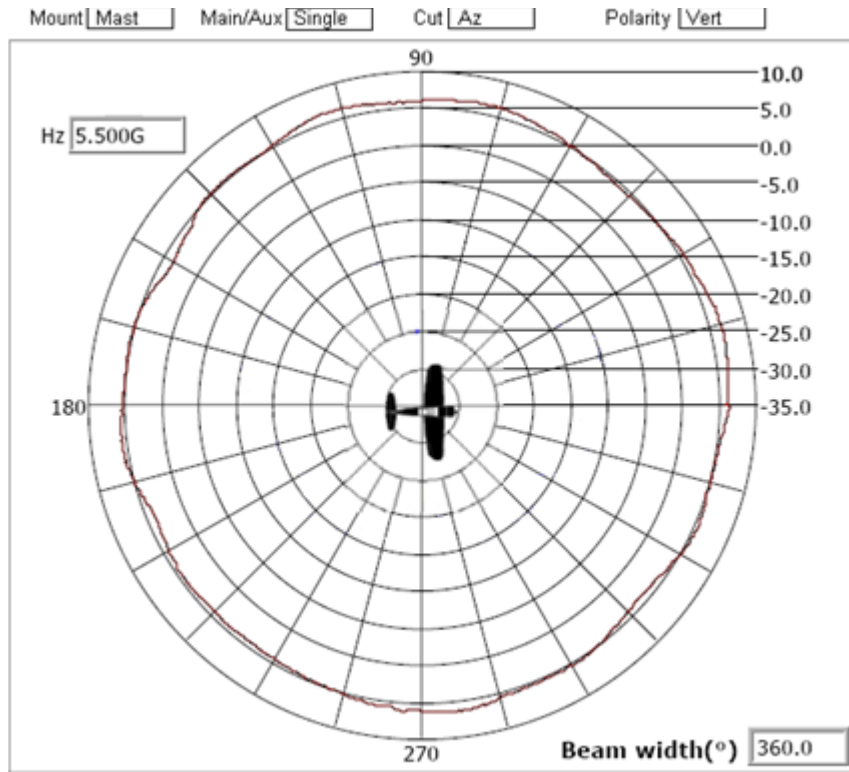

Azimuth Pattern

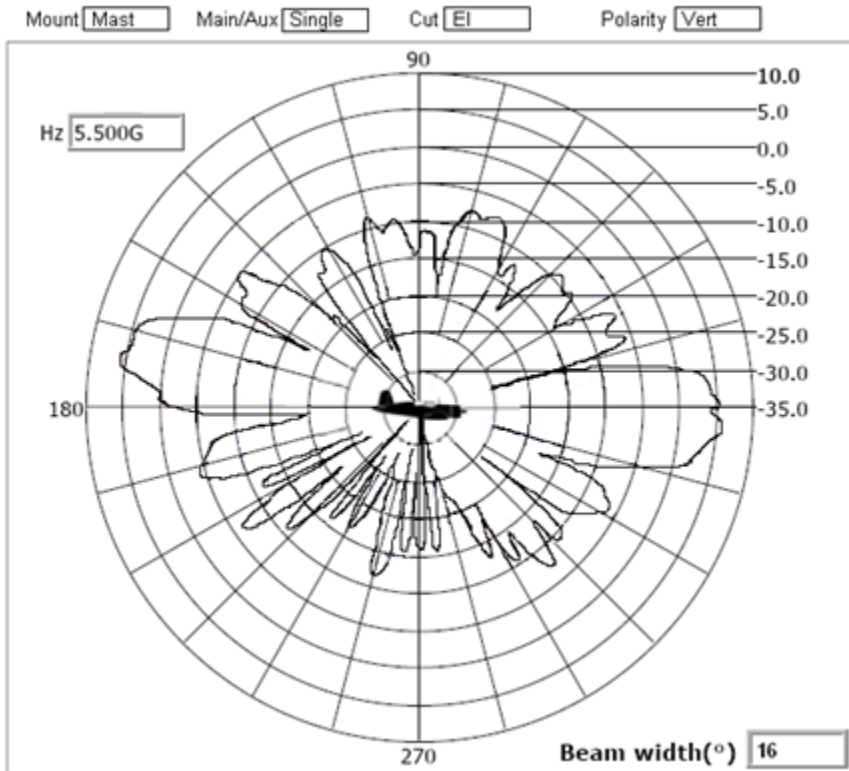

Elevation Pattern

4.1.7 ML-5299-BYGA15-012 Yagi Antenna: N-Female

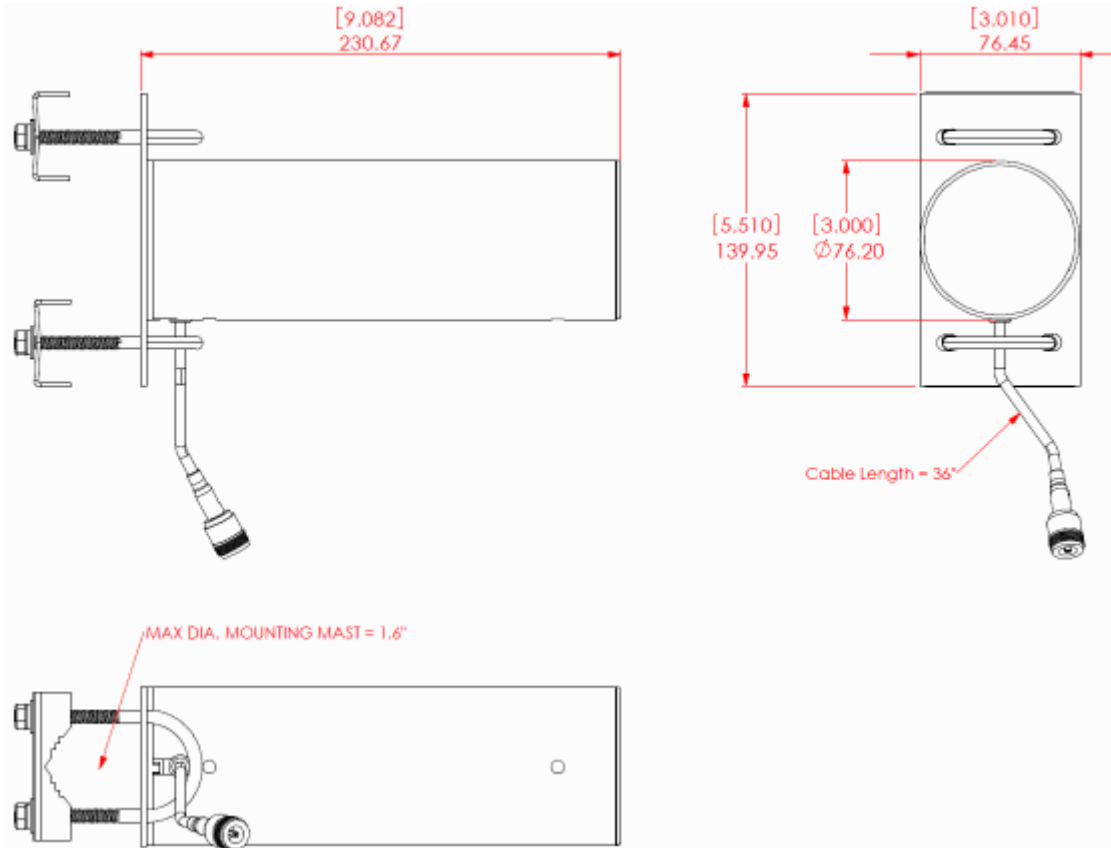

Type	Yagi
Frequency	4900-5800
Gain (dBi)	12.0
Polarization	Linear, Vertical
Azimuth	3dB Beamwidth: 31°
Elevation	3dB Beamwidth: 33°
Cable Length (in.)	N/A
Cable Type	ATX195
Connector Type	N Female
Weight	1.2 lbs
Plenum Antenna	No
Plenum Cable	No
Outdoor Rated	Yes

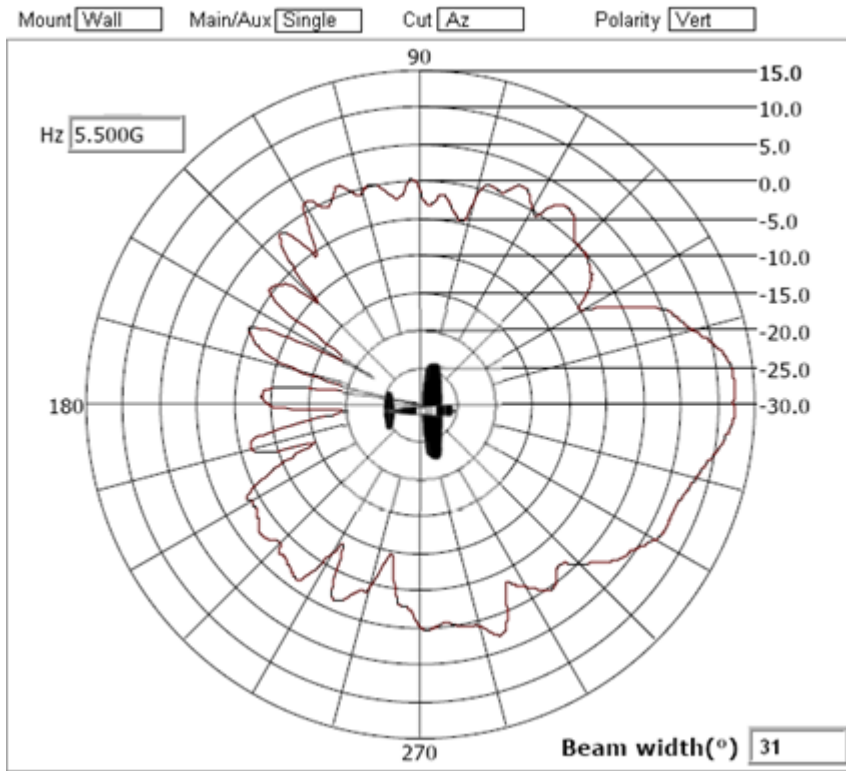

Azimuth Pattern

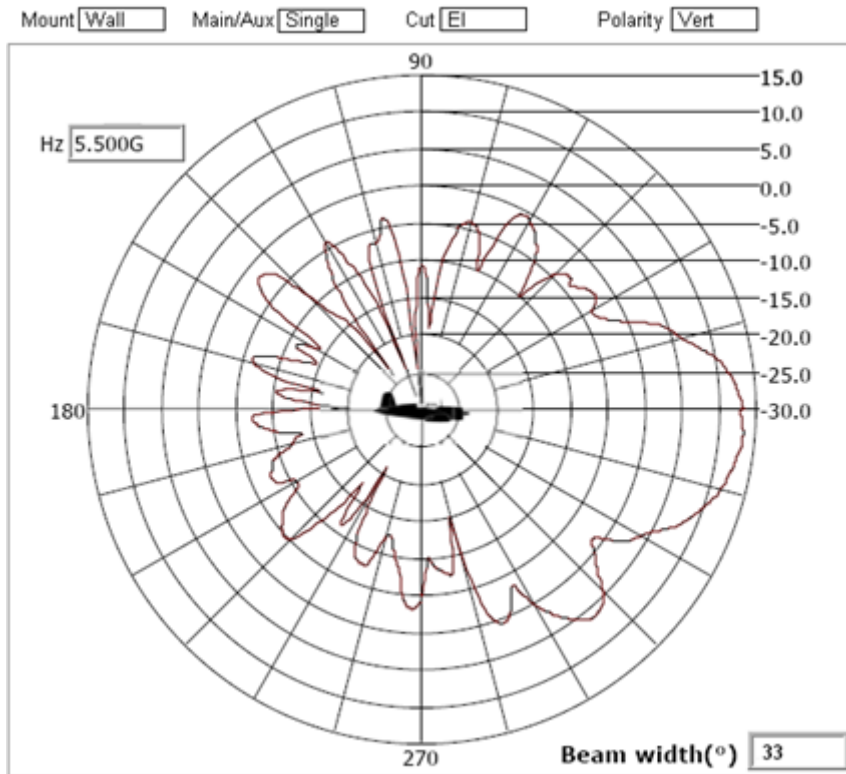

Elevation Pattern

2.4GHz - 5.2GHz Dual Band Antenna Suite

5.1 Supported 802.11a/b/g/n Dual Band Antennas

Motorola supports several 2.4GHz - 5.2GHz Dual Band antennas to suit the requirements of your unique access point or access port deployment. Check the Motorola Web site periodically, as newly supported 2.4GHz - 5.2GHz Dual Band antennas will be added to this document as they are released. For more information, go to <http://support.symbol.com/support/product/manuals.do>.

For detailed information on supported 2.4GHz - 5.2GHz Dual Band antenna models, refer to:

- *ML-2452-APA2-01 Indoor Dual Band Elbow Jointed Dipole: RP-SMA Male*
- *ML-2452-PNA5-01R Dual Band Panel: Connector Type N-Male*
- *ML-2452-PNA7-01R Dual Band Panel: Connector Type N-Male*
- *ML-2452-PTA2M3X3-1 AP-7131 MIMO Facade: 1 IN, RPSMA*
- *ML-2452-PTA3M3-036 Ceiling Mount, Dual Band, MIMO Patch: RPSMA*
- *ML-2452-APA6J-01 Dual Band Dipole, Microcell: RP-SMA Male*
- *ML-2452-HPA5-036 Dipole, RP-SMA-Male*
- *ML-2452-PNL9M3-036 MIMO Dual Band Selector, RP-SMA Male*

5.1.1 ML-2452-APA2-01 Indoor Dual Band Elbow Jointed Dipole: RP-SMA Male

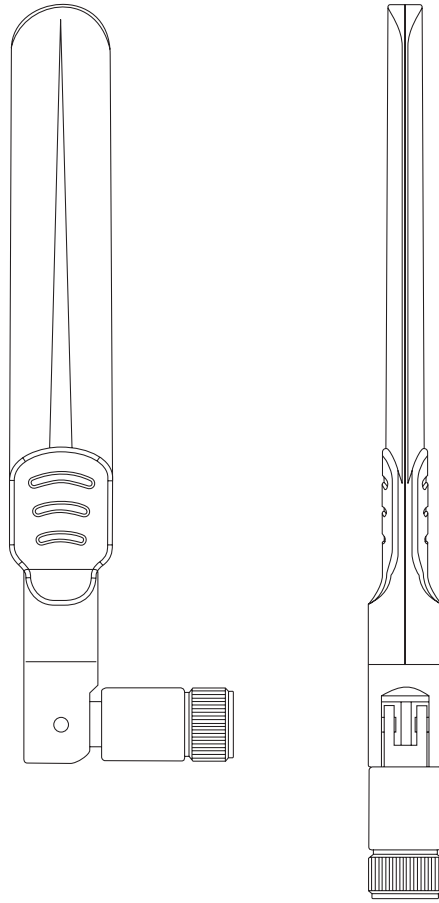

Type	Dipole
Frequency	2400-2500/5150-5850 MHz
Gain (dBi)	6 / 7
Polarization	Linear, Vertical
Azimuth	3dB Beamwidth: 360°
Elevation	3dB Beamwidth: 35°
Cable Length (in.)	N/A
Cable Type	N/A
Connector Type	RP-SMA Male
Weight	0.7 oz
Plenum Antenna	No
Plenum Cable	N/A
Outdoor Rated	No

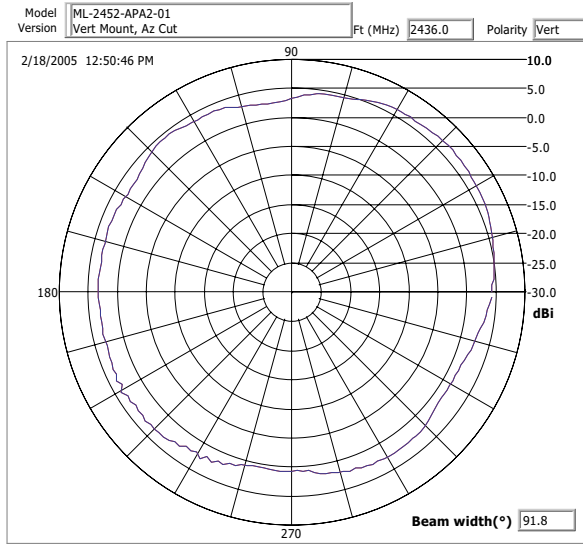

Azimuth Pattern

802.11b Band

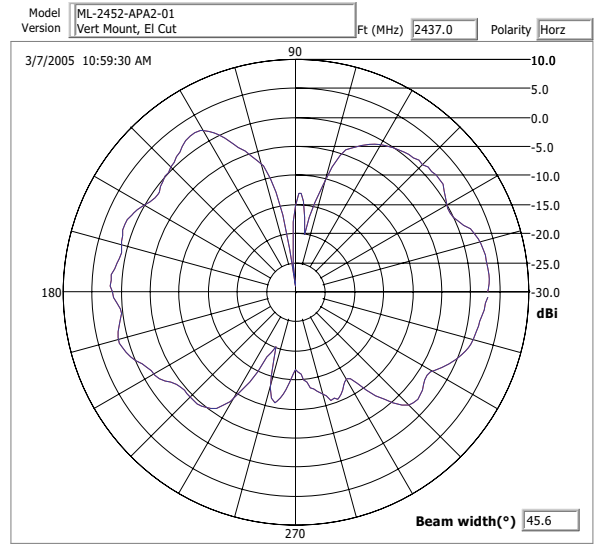

Elevation Pattern

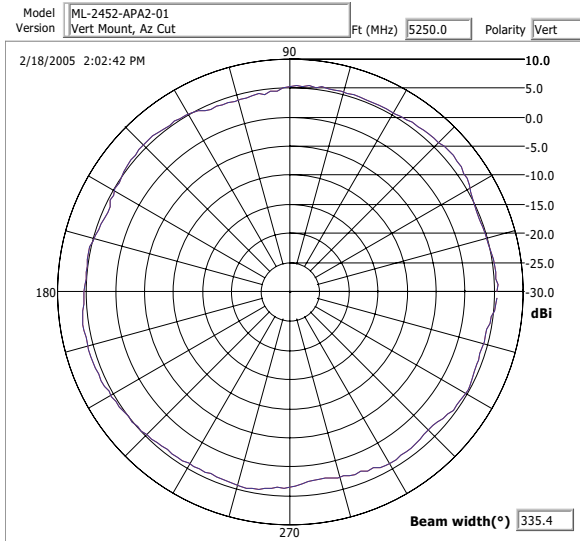

Azimuth Pattern

802.11a Band

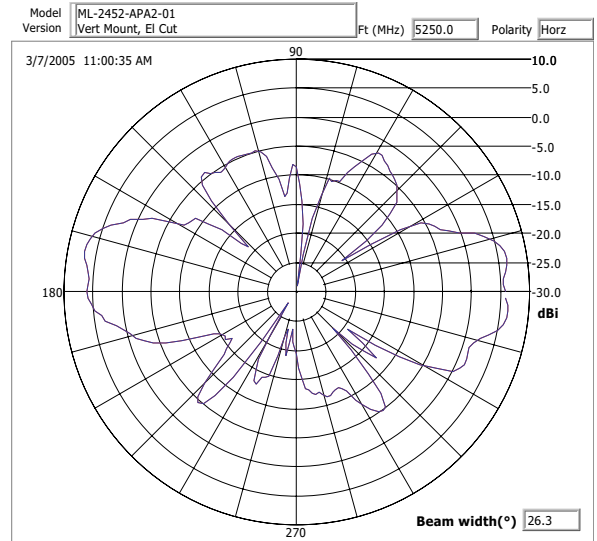

Elevation Pattern

5.1.2 ML-2452-PNA5-01R Dual Band Panel: Connector Type N-Male

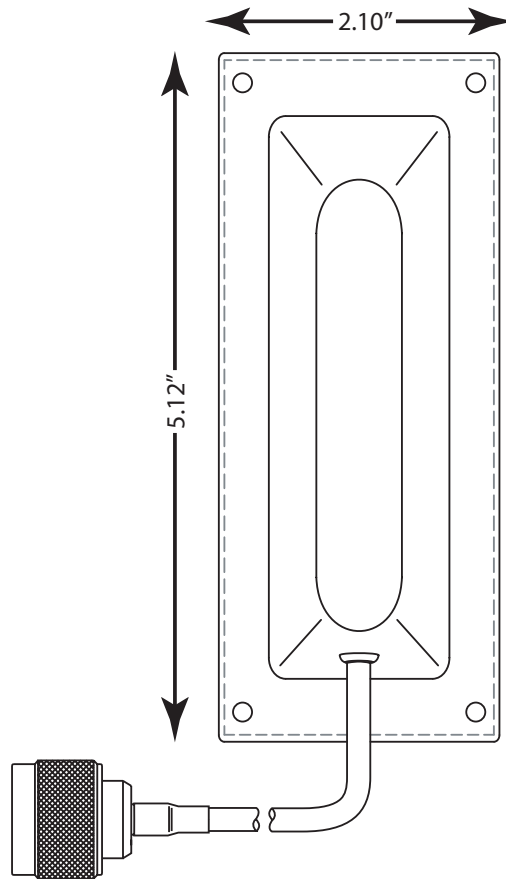

Type	Panel
Frequency	2400-2500/4900-5900 MHz
Gain (dBi)	4.5 (2400-2500); 5.0 (4900-5250); 4.0 (5250-5900)
Polarization	Linear, Vertical
Azimuth	3dB Beamwidth: 120°
Elevation	3dB Beamwidth: 65°
Cable Length (in.)	12
Cable Type	RG-58 Ultralink
Connector Type	Type N Male
Weight	0.2 lb
Plenum Antenna	No
Plenum Cable	Yes
Outdoor Rated	Yes

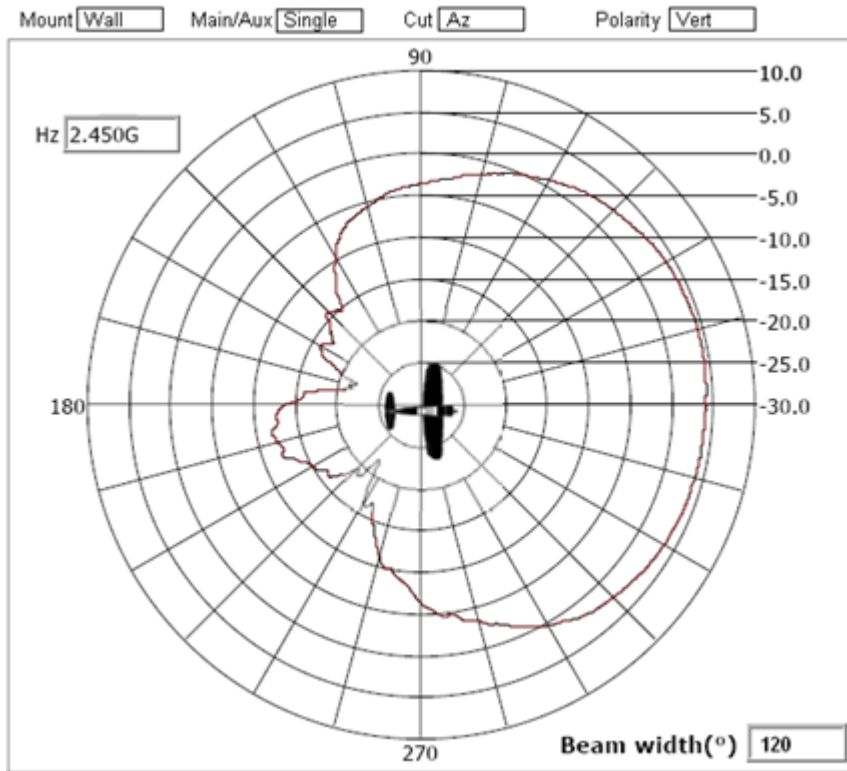

Azimuth Pattern

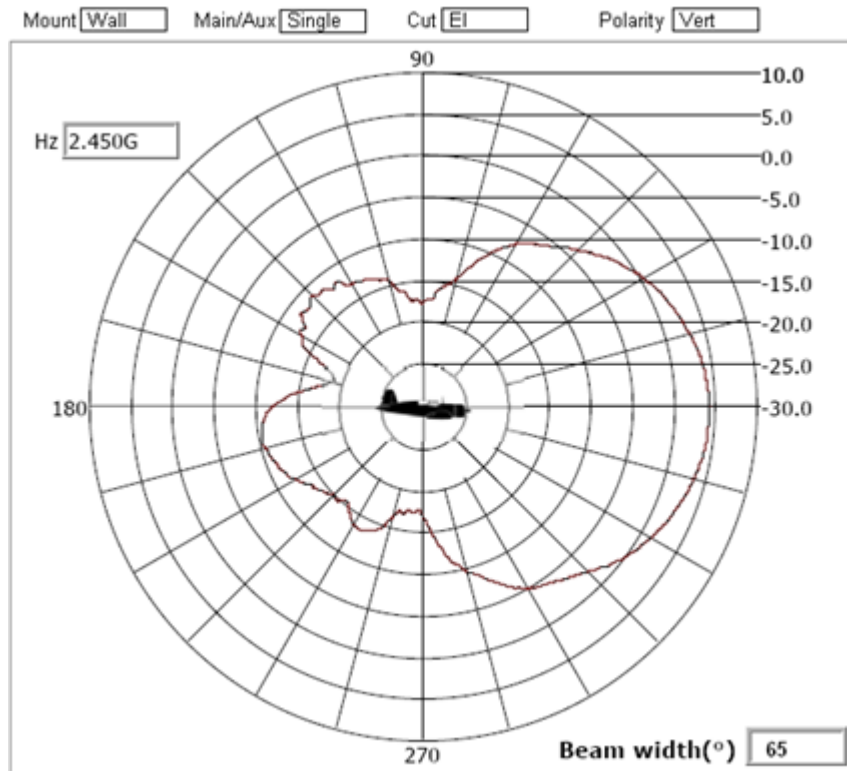

Elevation Pattern

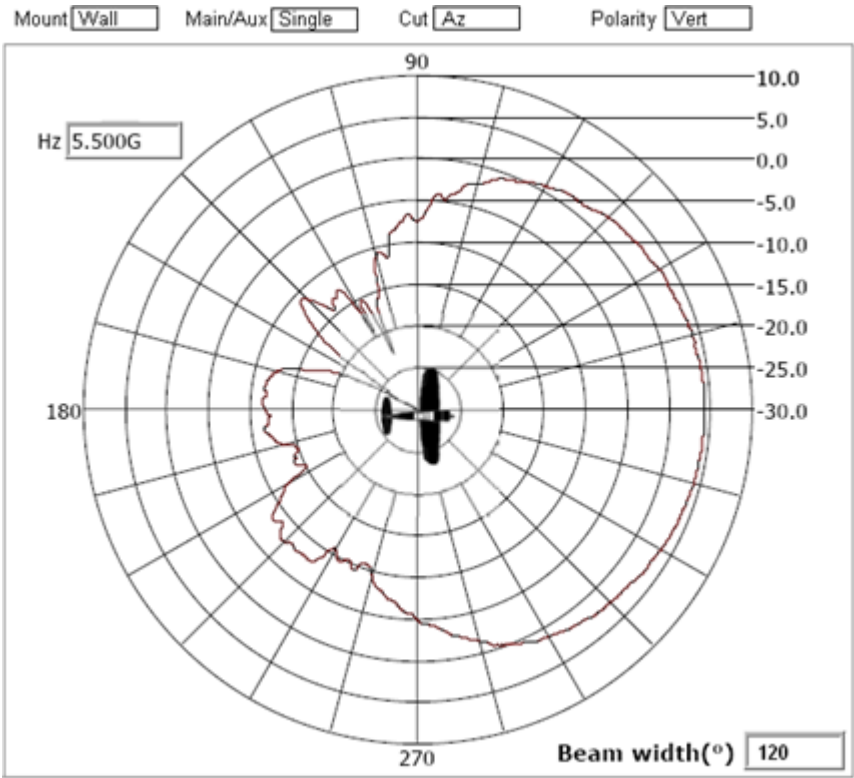

Azimuth Pattern

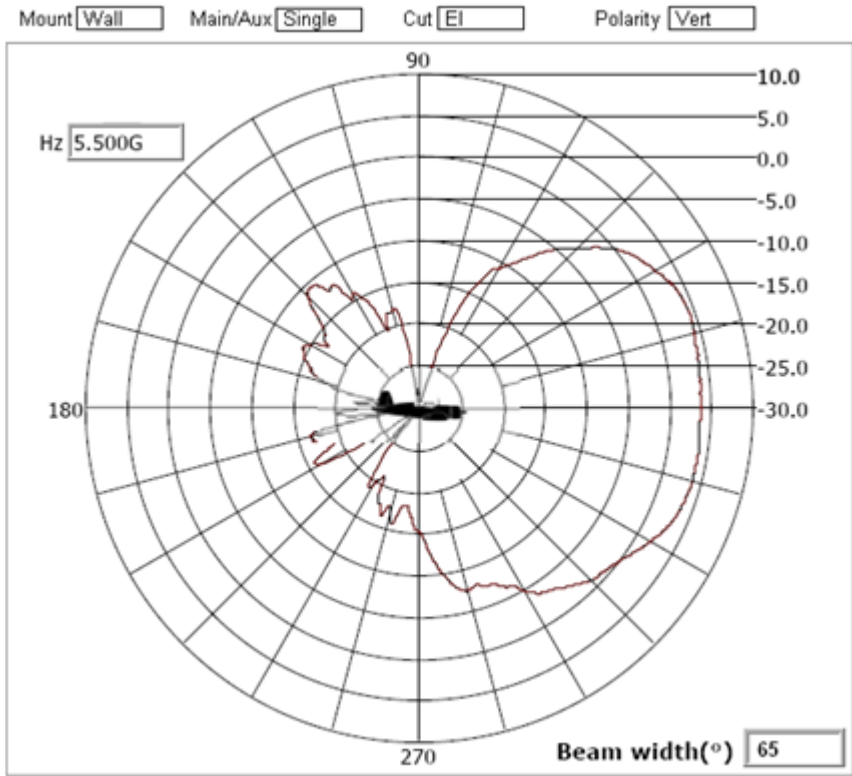

Elevation Pattern

5.1.3 ML-2452-PNA7-01R Dual Band Panel: Connector Type N-Male

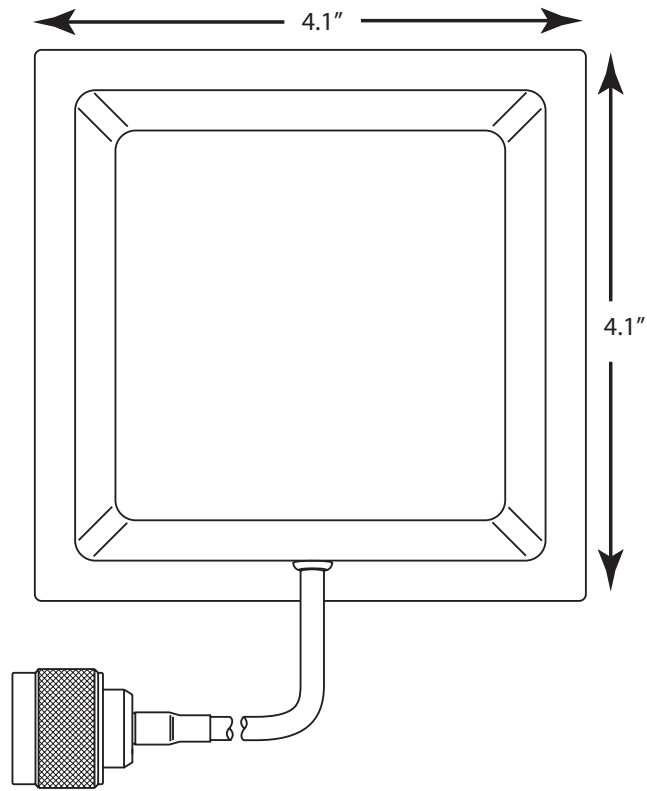

Type	Panel
Frequency	2400-2500/4900-5900 MHz
Gain (dBi)	7 (2400-2500); 6.3 (4900-5250); 9 (5250-5900)
Polarization	Linear, Vertical
Azimuth	3dB Beamwidth: 68° / 52°
Elevation	3dB Beamwidth: 66° / 60°
Cable Length (in.)	12
Cable Type	RG-58 Ultralink
Connector Type	Type N Male
Weight	0.5 lb
Plenum Antenna	No
Plenum Cable	Yes
Outdoor Rated	Yes

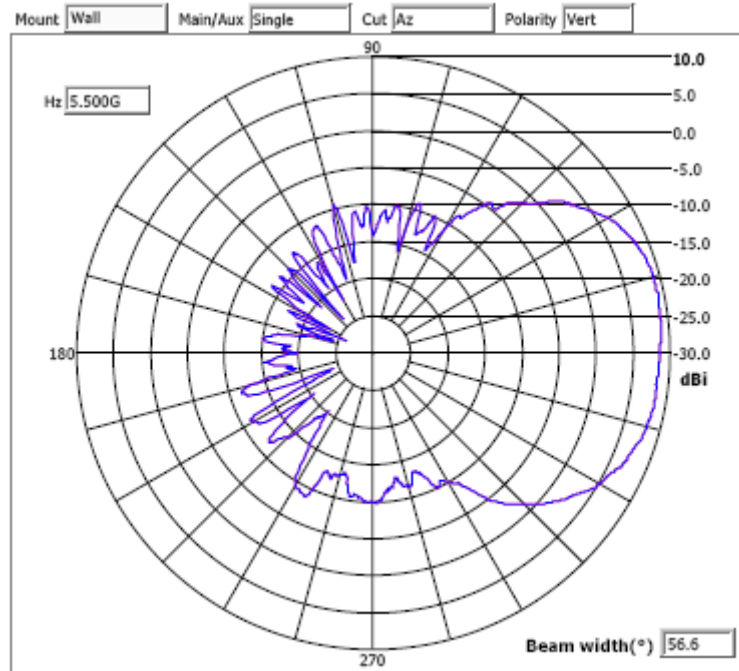
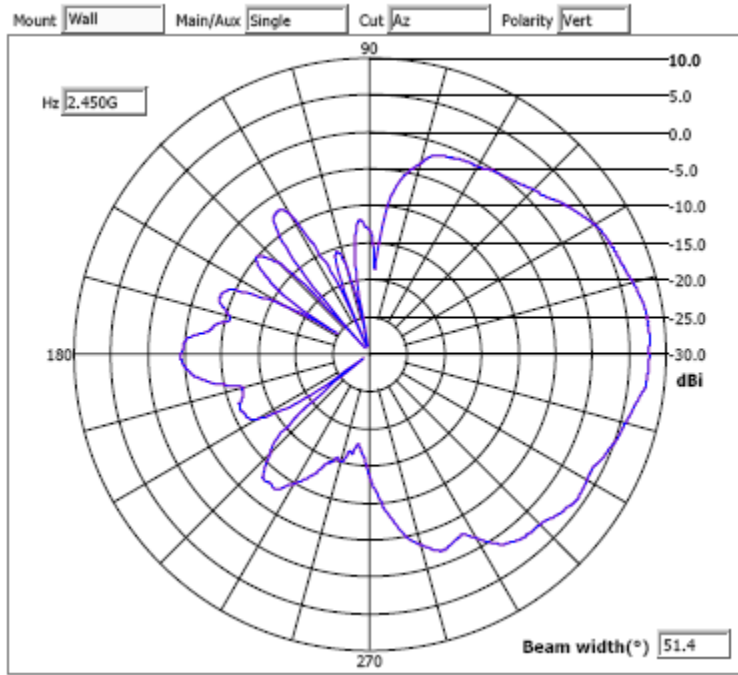

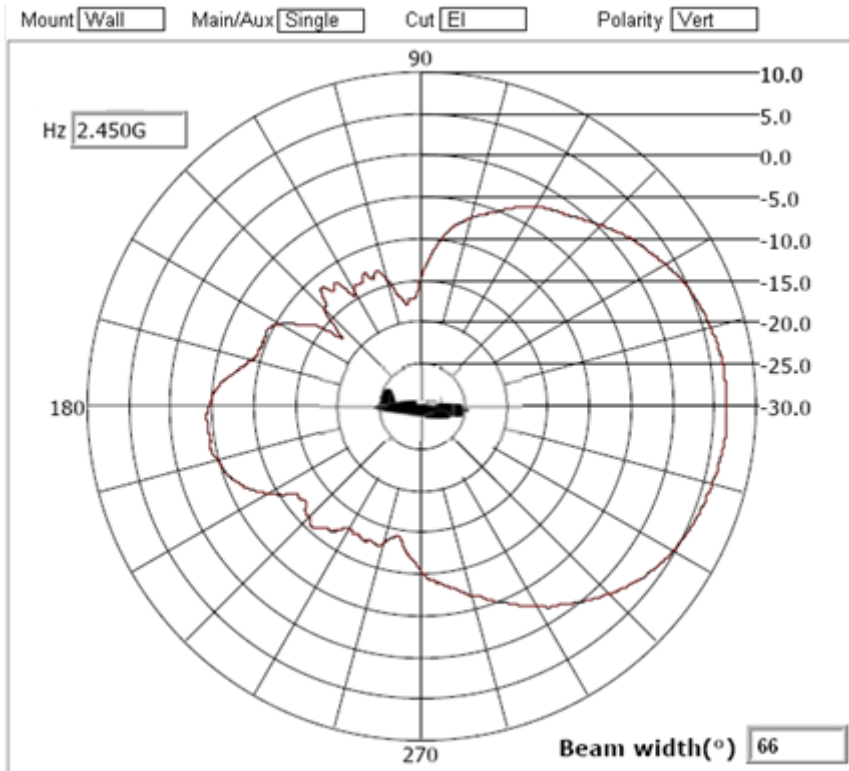

Elevation Pattern

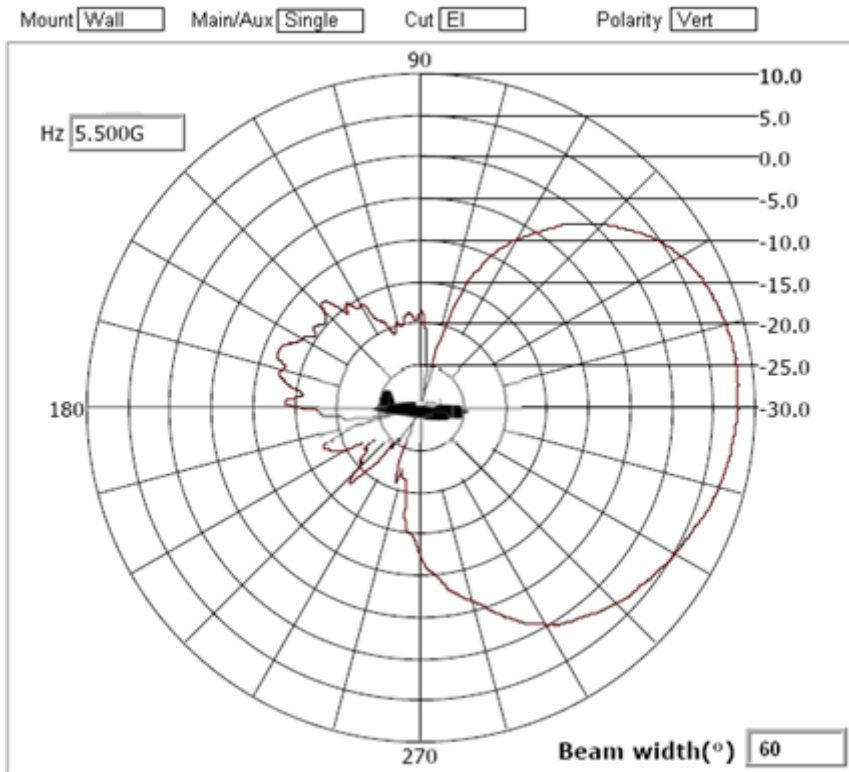

Elevation Pattern

5.1.4 ML-2452-PTA2M3X3-1 AP-7131 MIMO Facade: 1 IN, RPSMA

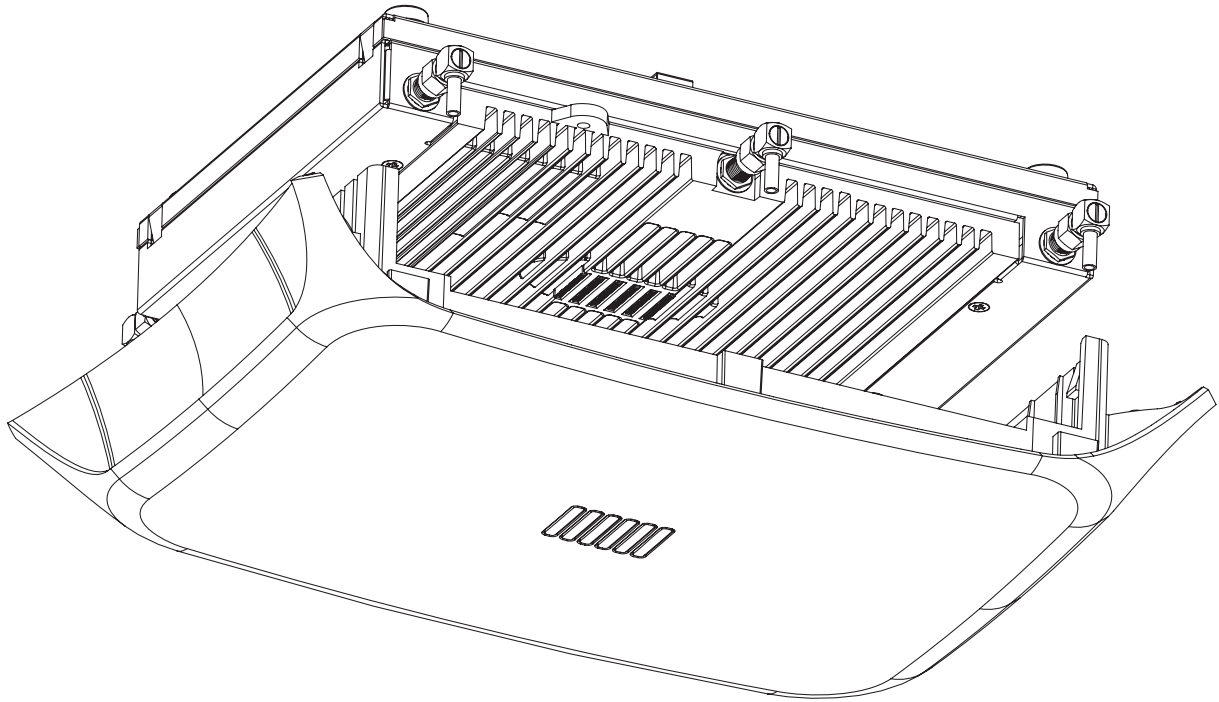

NOTE: ML-2452-PTA2M3x3-1 was formally released as Motorola part number ML-2452-APA2-FAC.

<i>Type</i>	Patch x 6 in snap-on facade
<i>Frequency</i>	2400-2500/4900-5990 MHz
<i>Gain (dBi)</i>	3 dBi 5 dBi
<i>Polarization</i>	Linear, Vertical
<i>Azimuth</i>	3dB Beamwidth: 360°
<i>Elevation</i>	3dB Beamwidth: 90° (southern hemisphere pattern)
<i>Cable Length (in.)</i>	Integrated into snap-on facade
<i>Cable Type</i>	1.20 mm coax
<i>Connector Type</i>	RP-SMA Male
<i>Antenna Plenum Rated</i>	No
<i>Cable Plenum Rated</i>	No
<i>Outdoor Rated</i>	No
<i>Weight</i>	0.79 lb

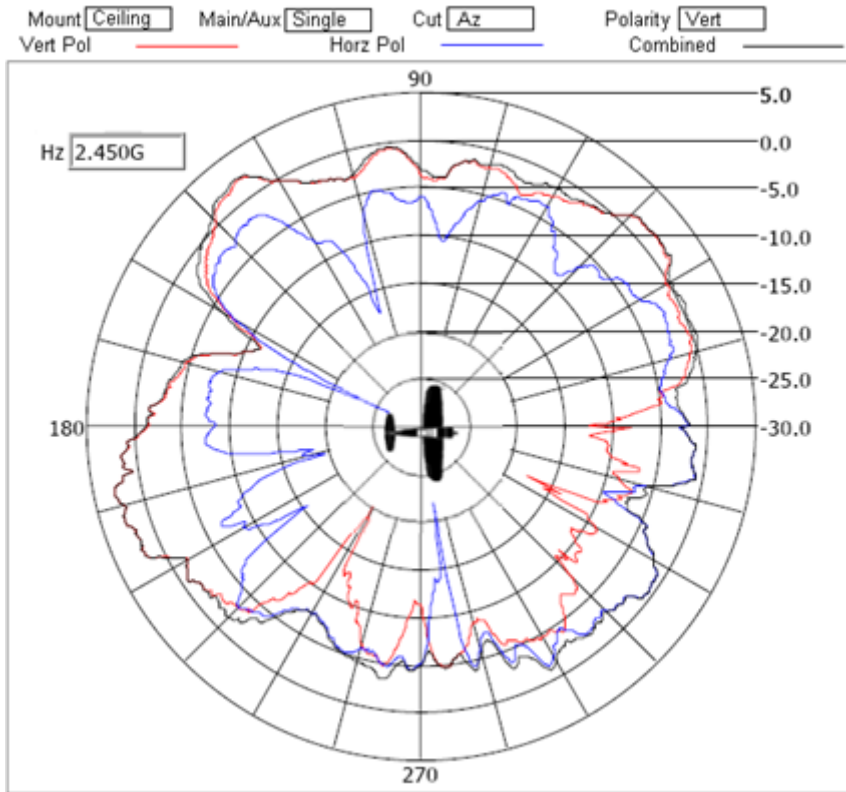

Azimuth Pattern

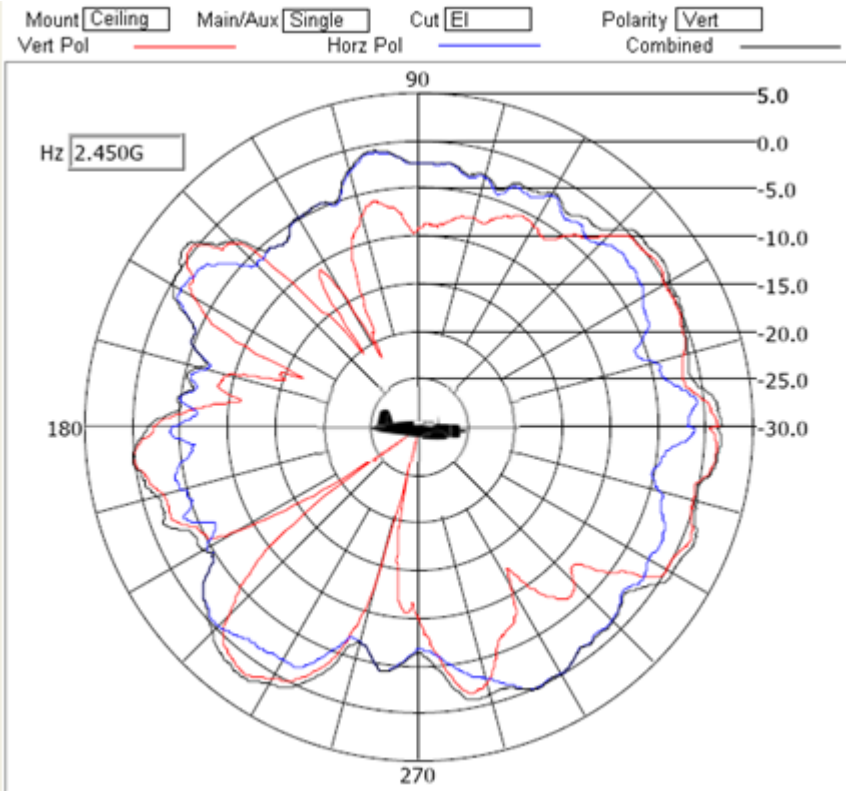

Elevation Pattern

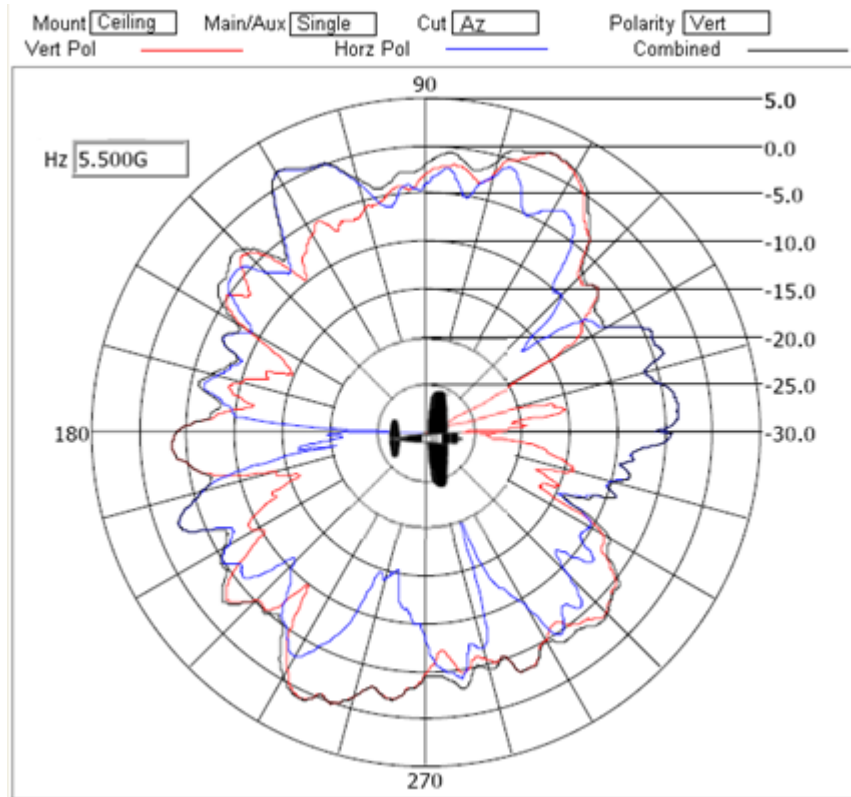

Azimuth Pattern

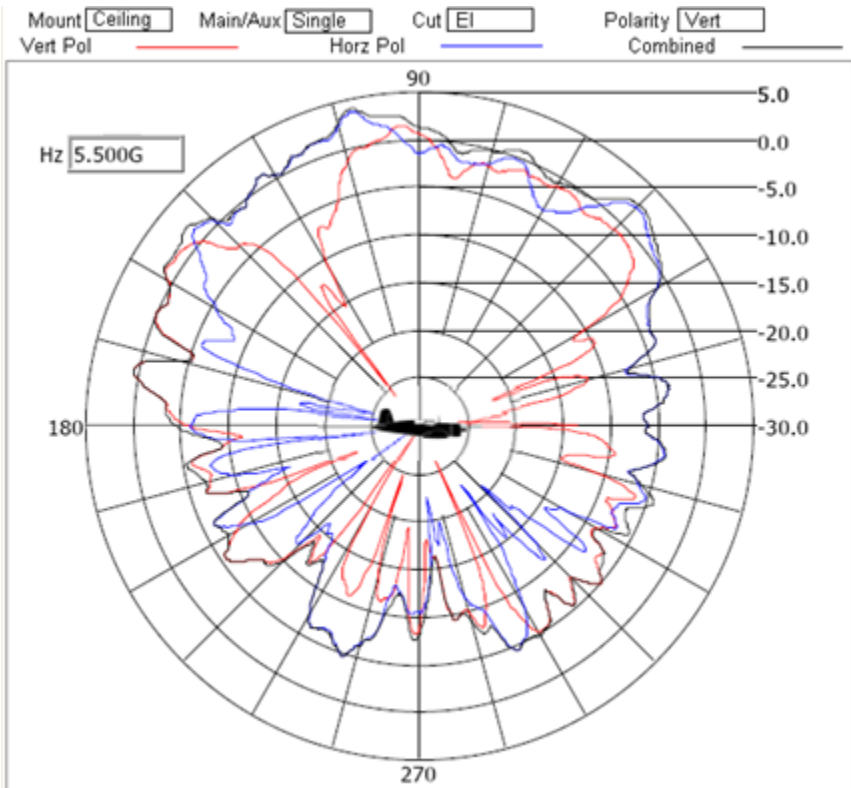

Elevation Pattern

5.1.5 ML-2452-PTA3M3-036 Ceiling Mount, Dual Band, MIMO Patch: RPSMA

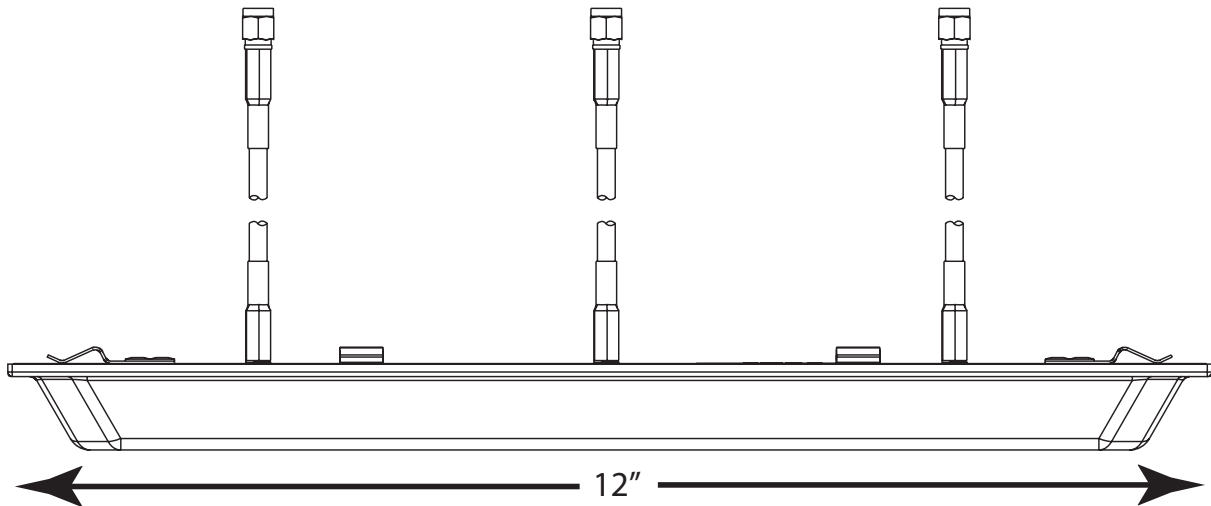

<i>Type</i>	Patch x 3
<i>Frequency</i>	2400-2500/4900-5990 MHz
<i>Gain (dBi)</i>	3 dBi 7 dBi
<i>Polarization</i>	Linear, Vertical
<i>Azimuth</i>	3dB Beamwidth: 360°
<i>Elevation</i>	3dB Beamwidth: 90° (southern hemisphere pattern)
<i>Cable Length (in.)</i>	36
<i>Cable Type</i>	RG-58 50 Ohm coax
<i>Connector Type</i>	RP-SMA Male
<i>Antenna Plenum Rated</i>	No
<i>Cable Plenum Rated</i>	Yes
<i>Outdoor Rated</i>	No
<i>Weight</i>	0.7 lb

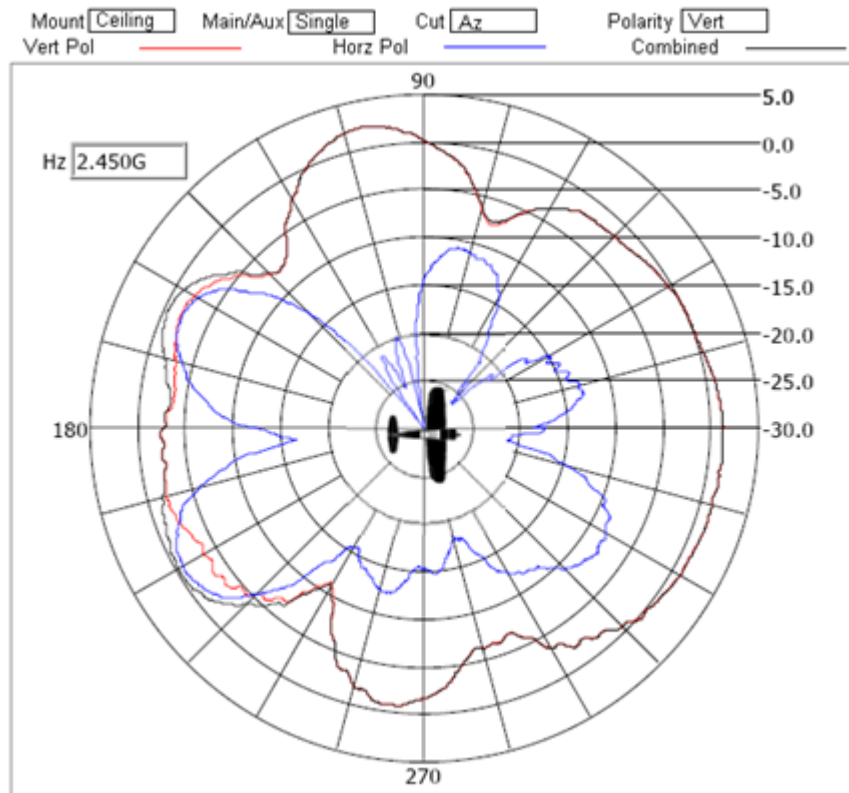

Azimuth Pattern

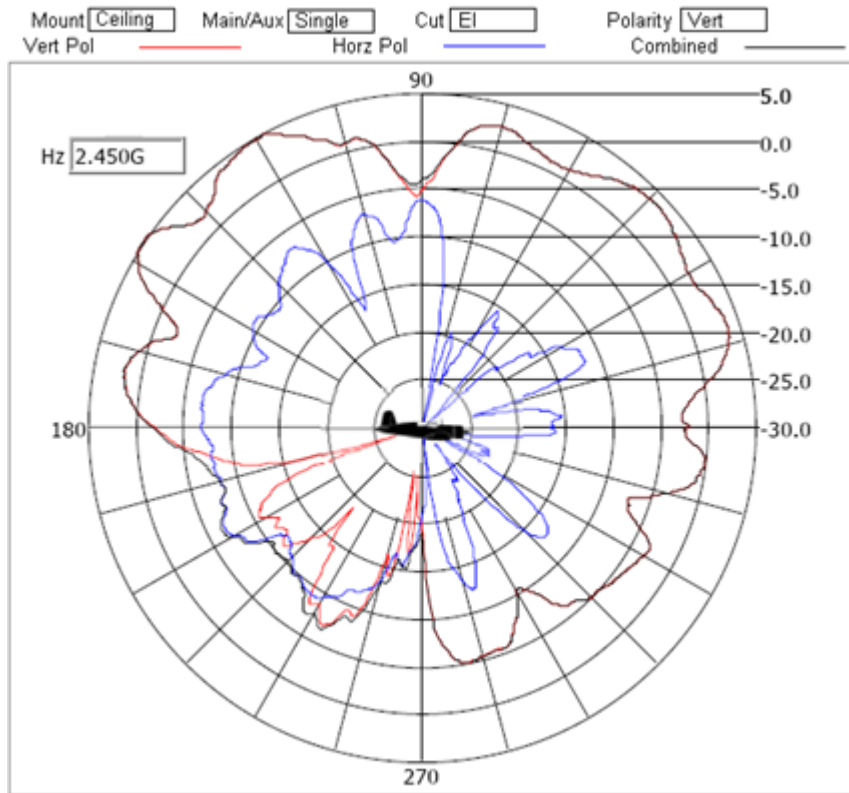

Elevation Pattern

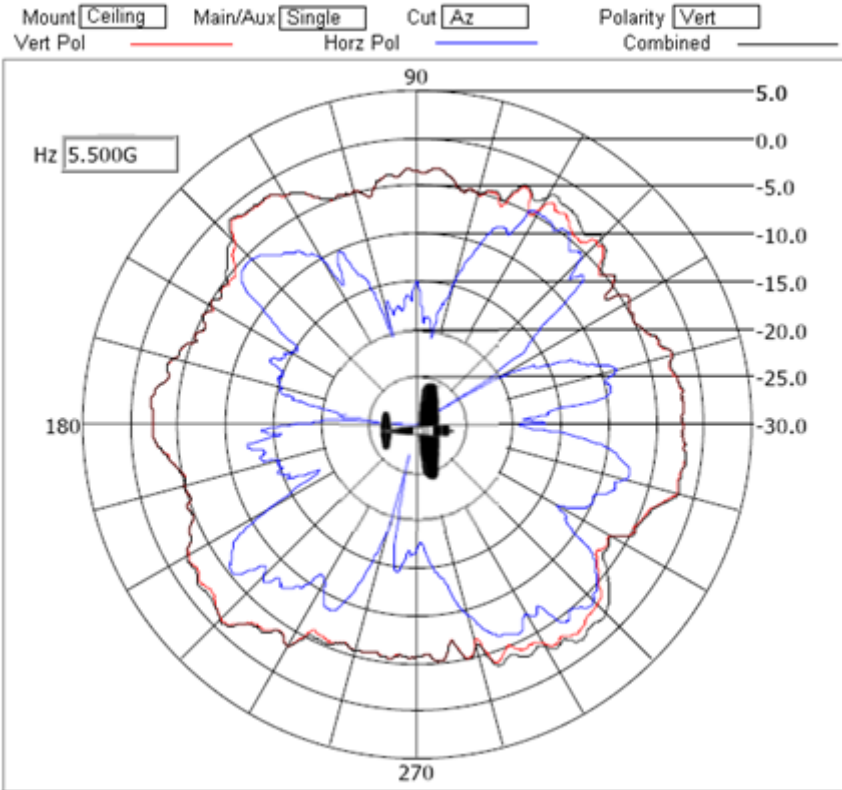

Azimuth Pattern

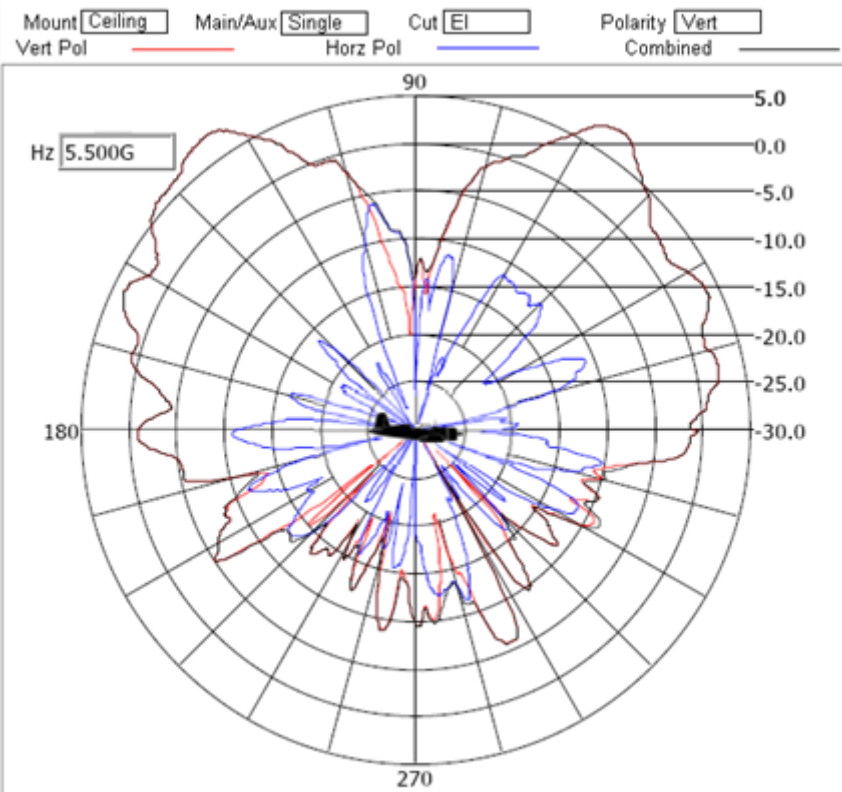

Elevation Pattern

5.1.6 ML-2452-APA6J-01 Dual Band Dipole, Microcell: RP-SMA Male

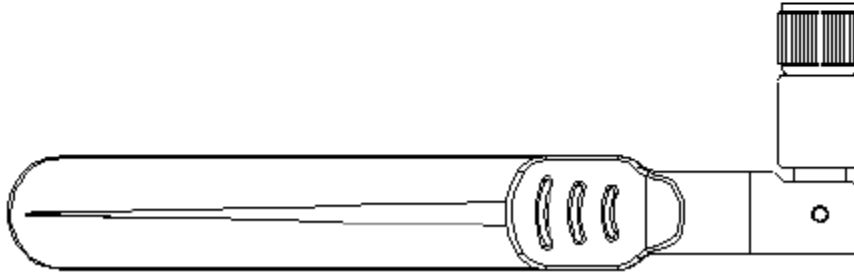
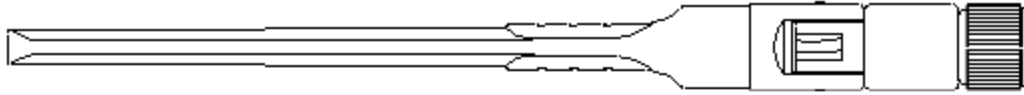

<i>Type</i>	Dipole
<i>Frequency</i>	2400-2500/4900-5850 MHz
<i>Gain (dBi)</i>	-6 / -8
<i>Polarization</i>	Linear, Vertical
<i>Azimuth</i>	3dB Beamwidth: 360°
<i>Elevation</i>	3dB Beamwidth: 35°
<i>Cable Length (in.)</i>	N/A
<i>Cable Type</i>	N/A
<i>Connector Type</i>	RP-SMA Male
<i>Antenna Plenum Rated</i>	N/A
<i>Cable Plenum Rated</i>	No
<i>Outdoor Rated</i>	N/A
<i>Weight</i>	0.76 oz

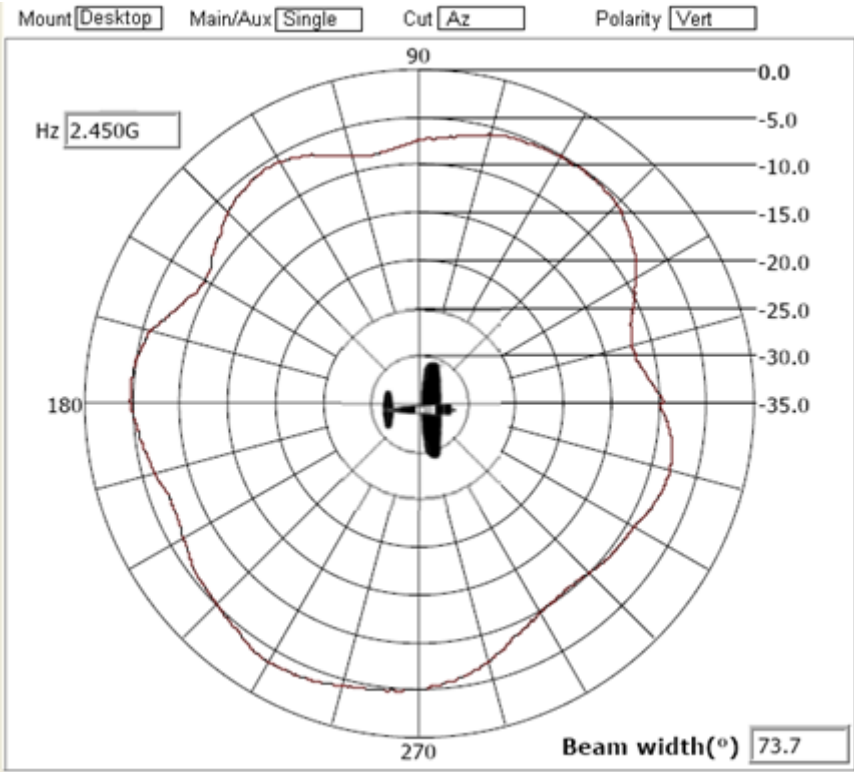

Azimuth Pattern

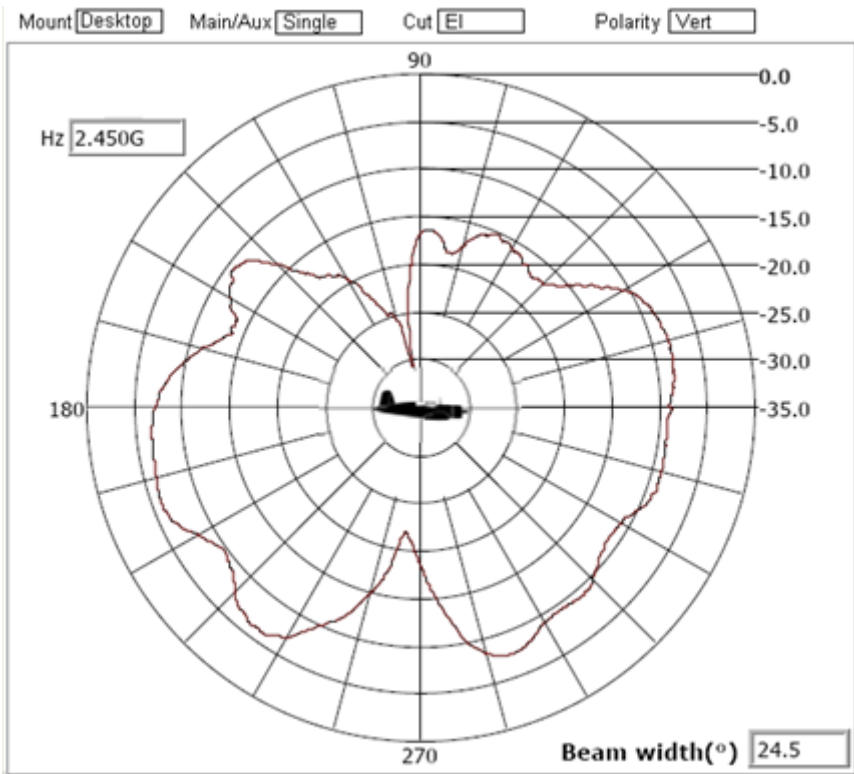

Elevation Pattern

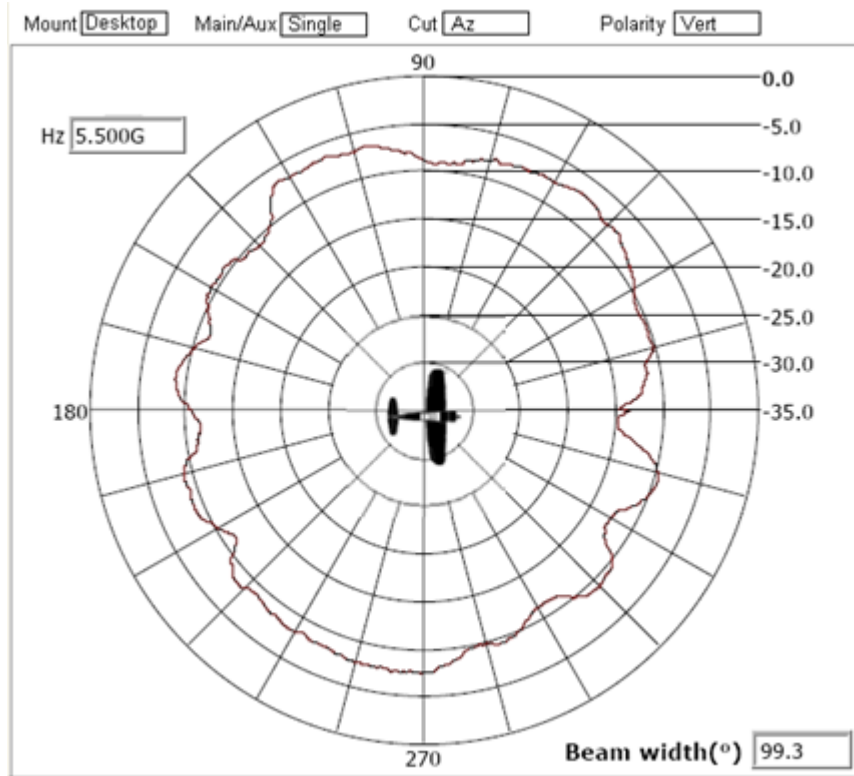

Azimuth Pattern

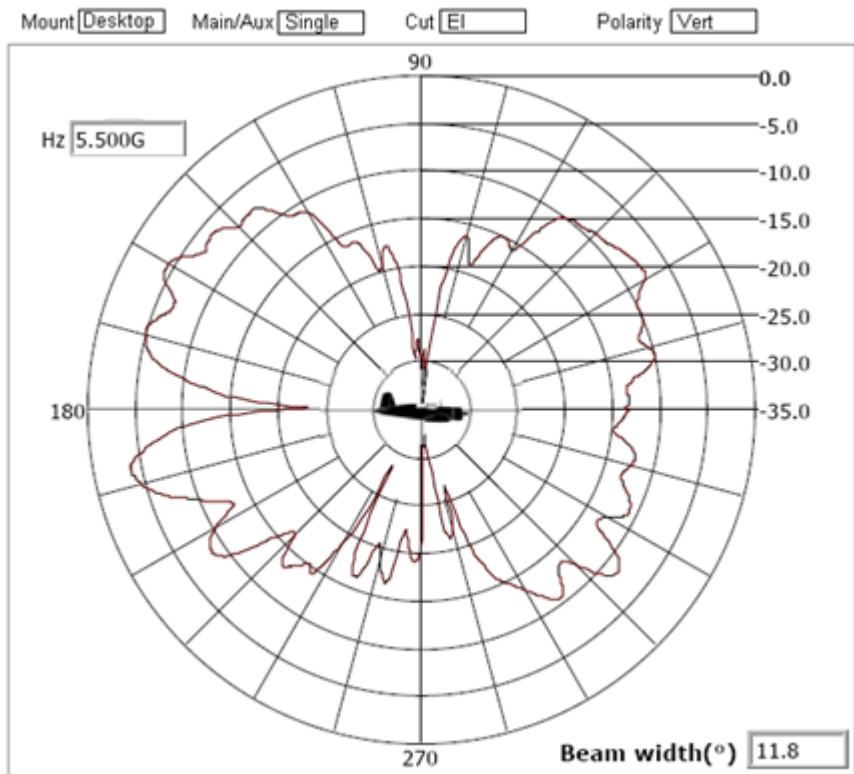

Elevation Pattern

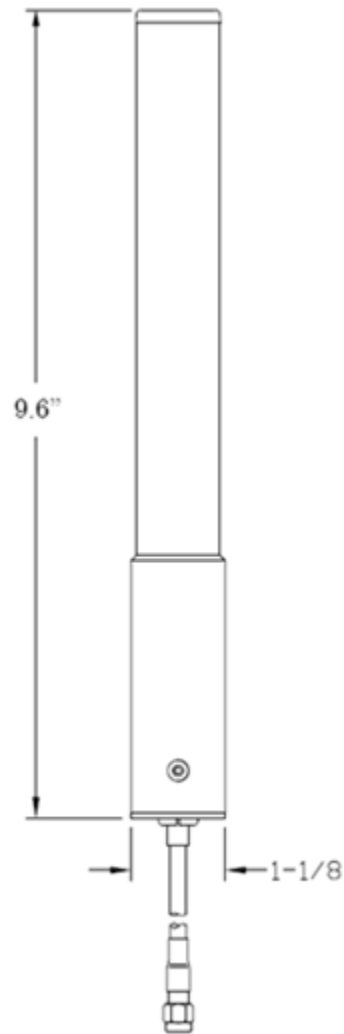
5.1.7 ML-2452-HPA5-036 Dipole, RP-SMA-Male

<i>Type</i>	Dipole
<i>Frequency</i>	2450-2500/5150-5875 MHz
<i>Gain (dBi)</i>	2.9 / 4.9
<i>Polarization</i>	Linear, Vertical
<i>Azimuth</i>	3dB Beamwidth: 360°
<i>Elevation</i>	3dB Beamwidth: 44°, 18°
<i>Cable Length (in.)</i>	243.8 (36)
<i>Cable Type</i>	RG-58 Plenum
<i>Connector Type</i>	RP-SMA Male
<i>Antenna Plenum Rated</i>	N/A
<i>Cable Plenum Rated</i>	N/A
<i>Outdoor Rated</i>	N/A
<i>Weight</i>	0.3 lbs

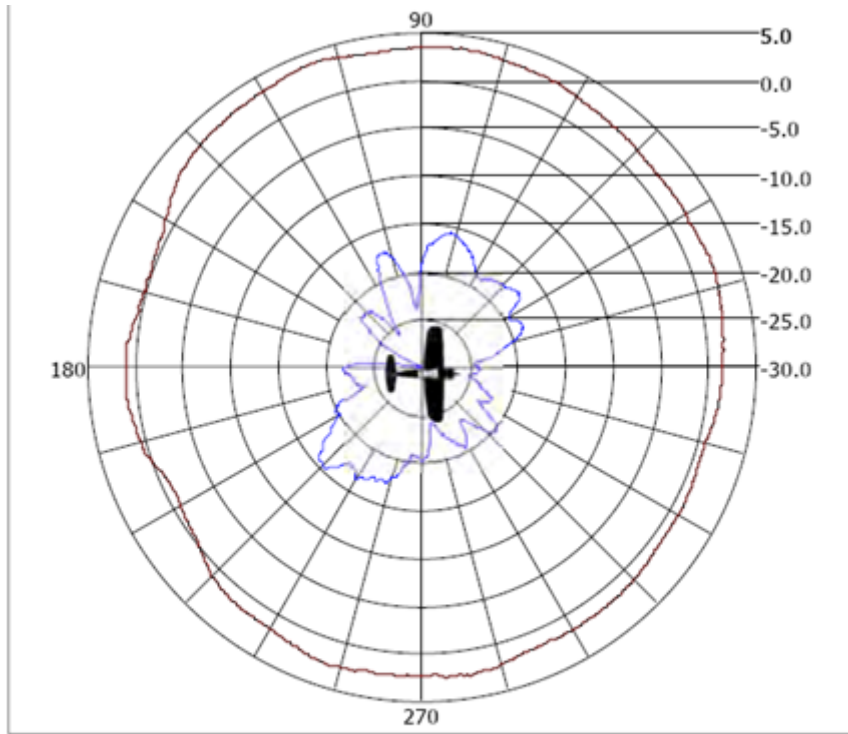

Azimuth Antenna Pattern

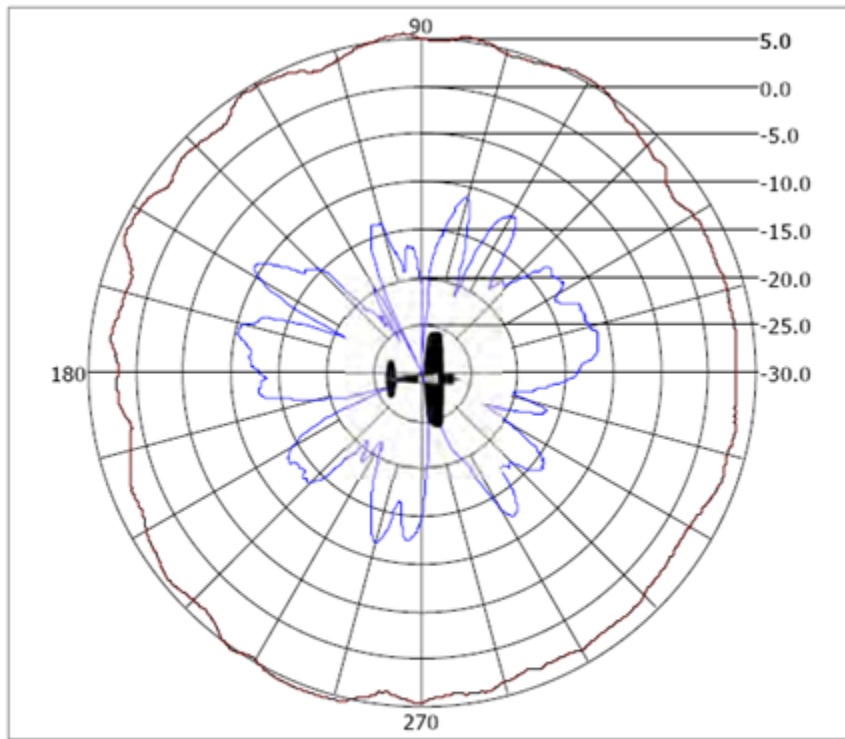

Azimuth Antenna Pattern

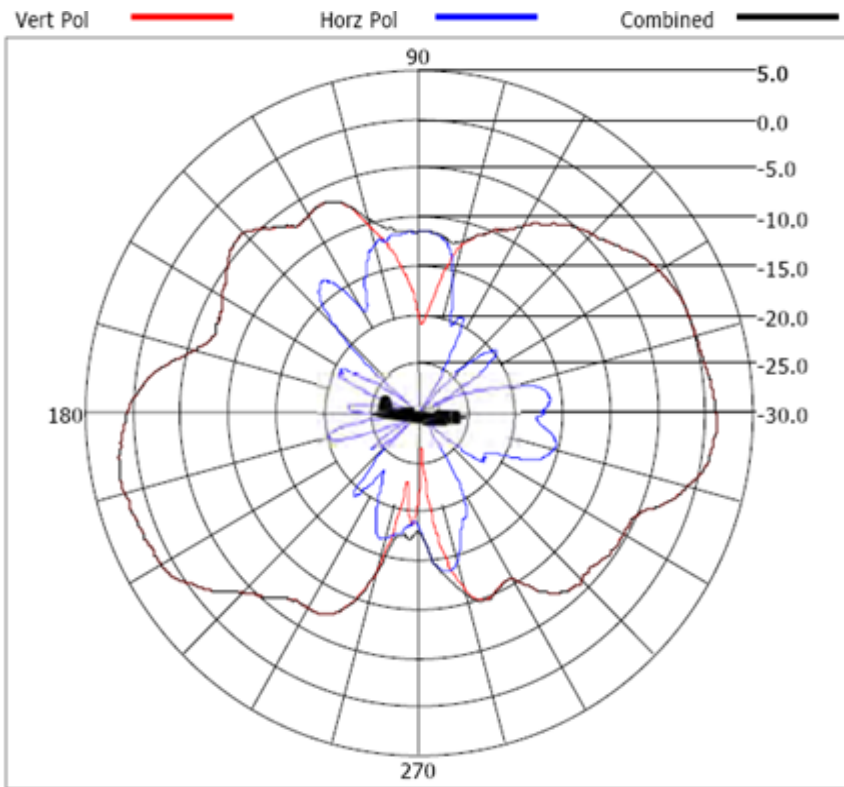

Elevation Antenna Pattern

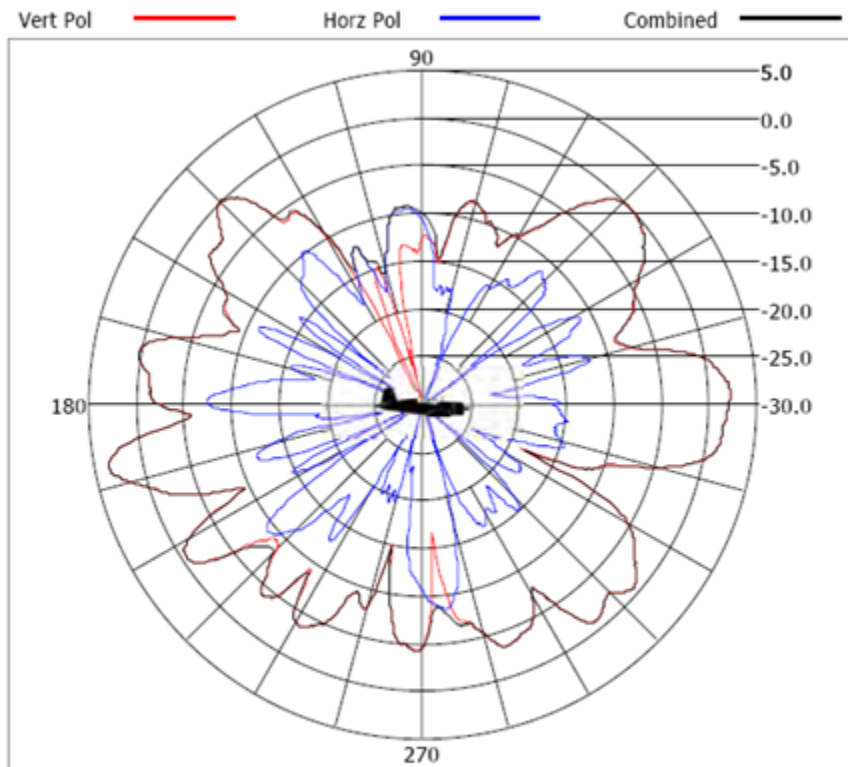

Elevation Antenna Pattern

5.1.8 ML-2452-PNL9M3-036 MIMO Dual Band Selector, RP-SMA Male

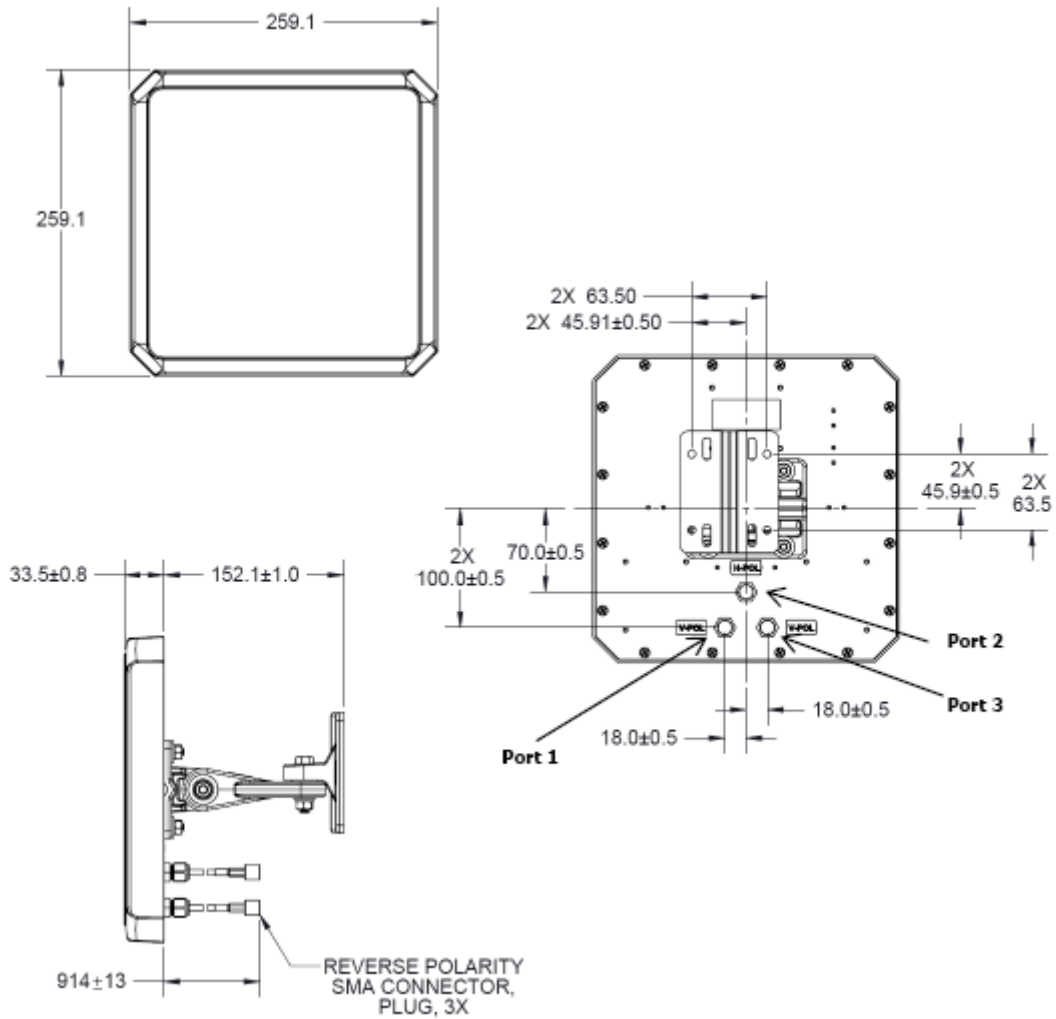

NOTE: The dimensions for the ML-2452-PNL9M3-036 model antenna are displayed in millimeters (mm) within the illustration above.

<i>Type</i>	MIMO Dual Band Selector
<i>Frequency</i>	2450-2500/5150-5875 MHz
<i>Gain (dBi)</i>	8.0 / 10.7
<i>Polarization</i>	Linear, Vertical
<i>Azimuth</i>	3dB Beamwidth: 75° / 55°
<i>Elevation</i>	3dB Beamwidth: 70° / 60°
<i>Cable Length (in.)</i>	36
<i>Cable Type</i>	Low Temperature Plenum
<i>Connector Type</i>	RP-SMA Male
<i>Antenna Plenum Rated</i>	N/A
<i>Cable Plenum Rated</i>	No
<i>Outdoor Rated</i>	N/A
<i>Weight</i>	1.81 lbs

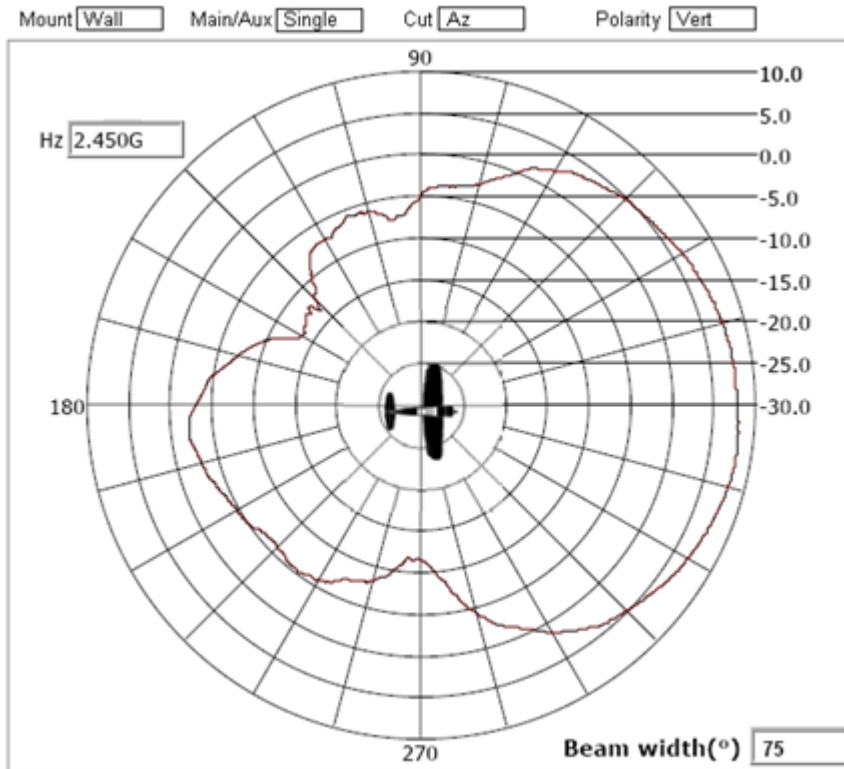

Port 1 Azimuth Pattern

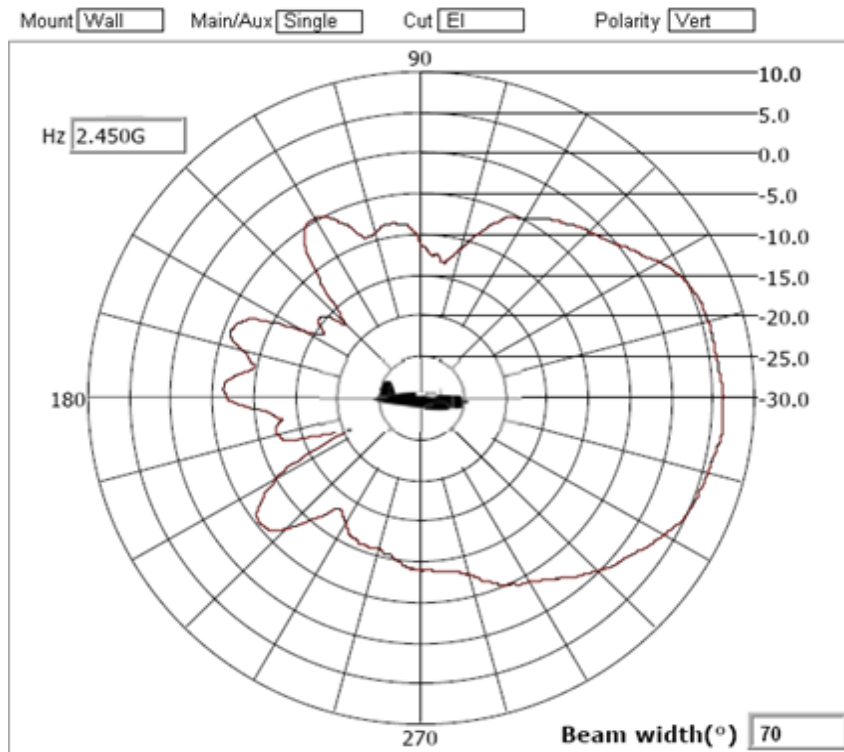

Port 1 Elevation Pattern

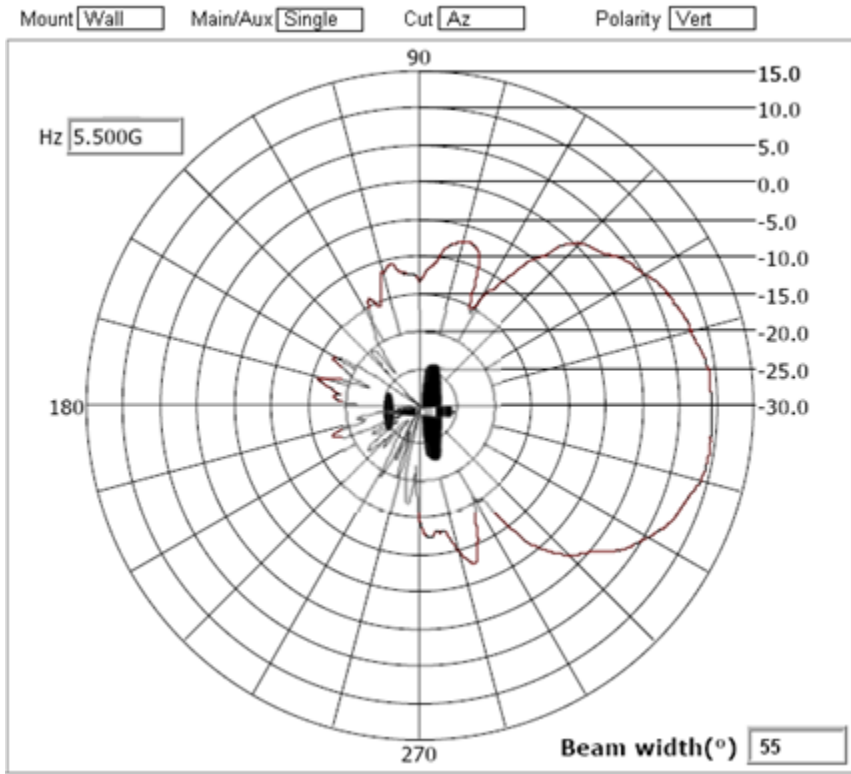

Port 1 Azimuth Pattern

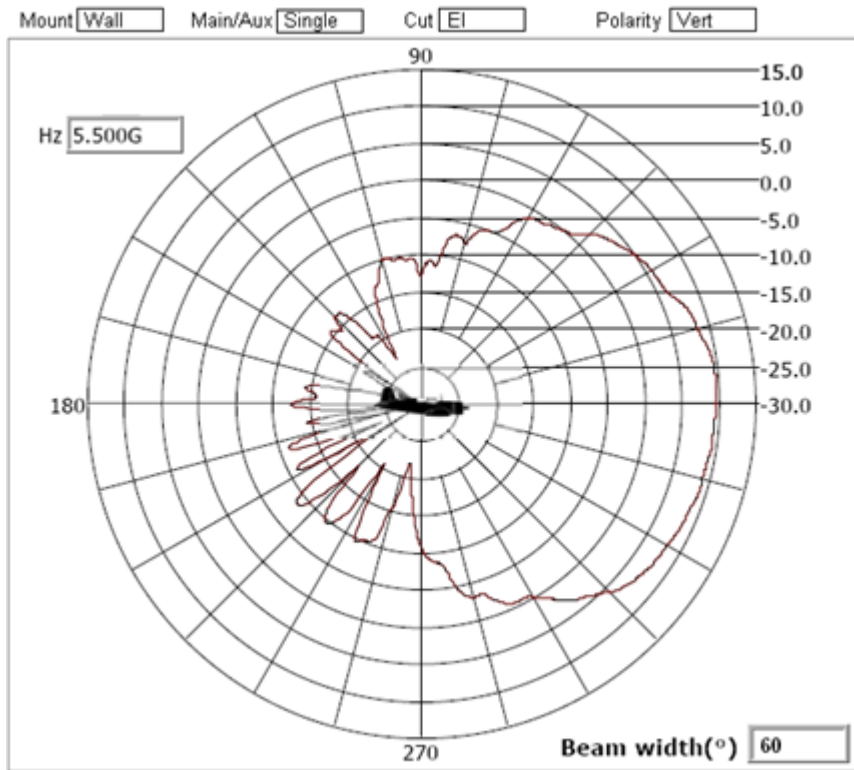

Port 1 Elevation Pattern

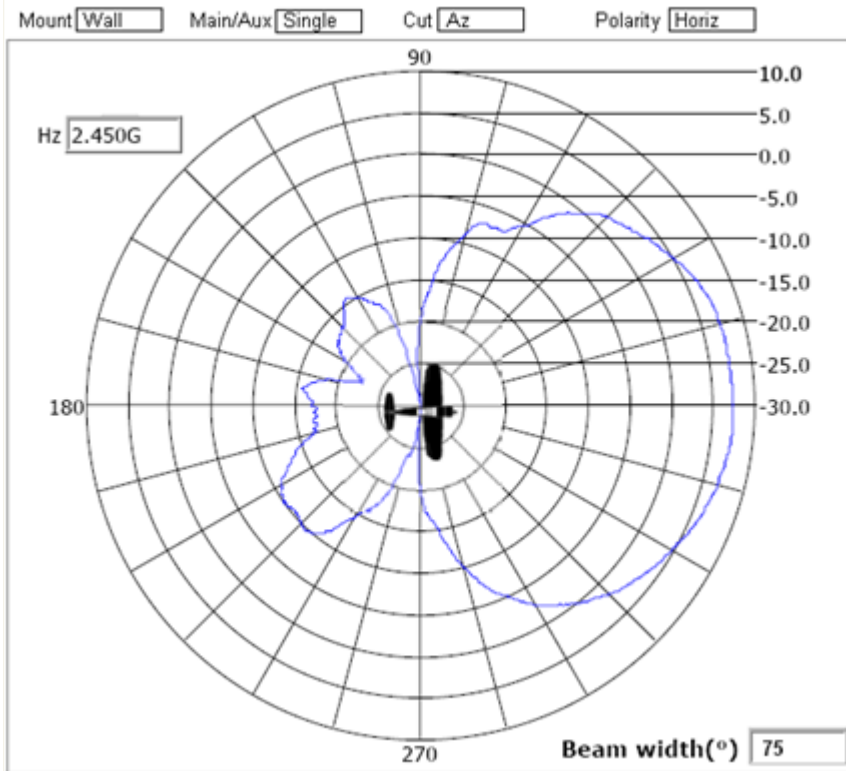

Port 2 Azimuth Pattern

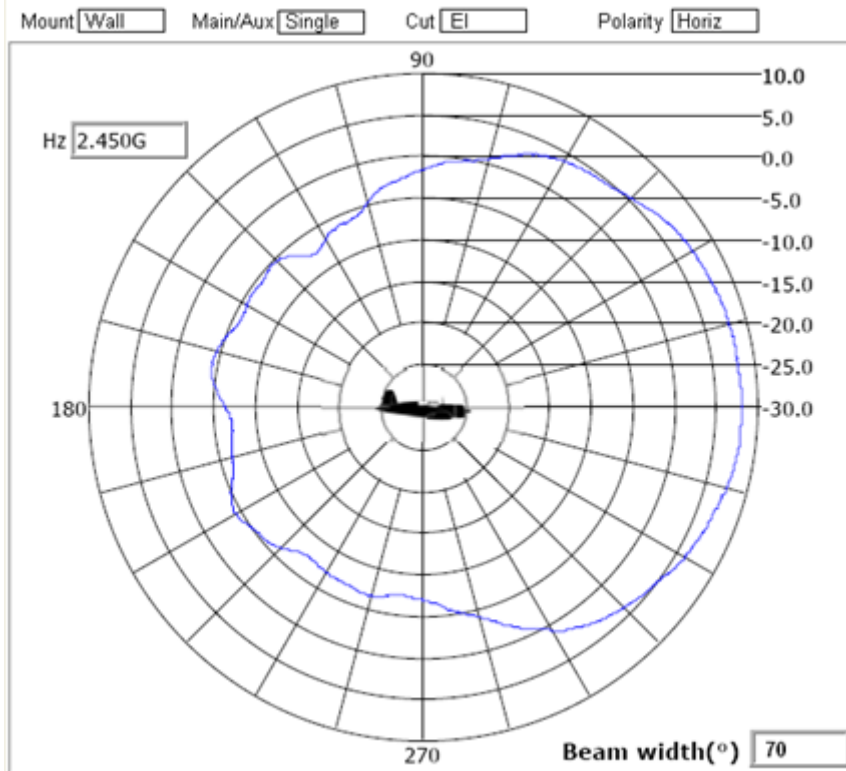

Port 2 Elevation Pattern

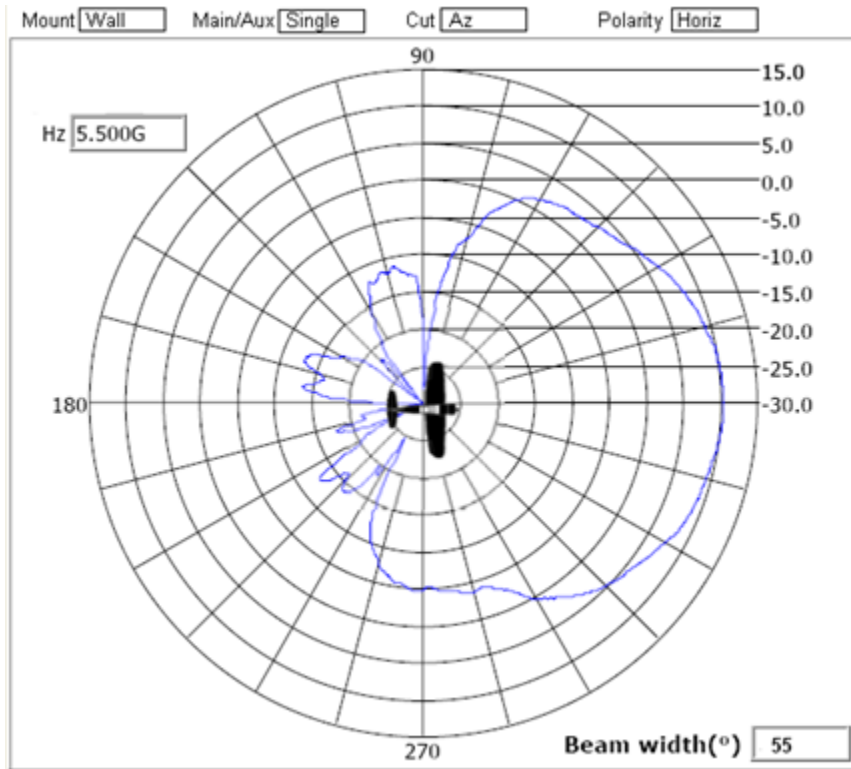

Port 2 Azimuth Pattern

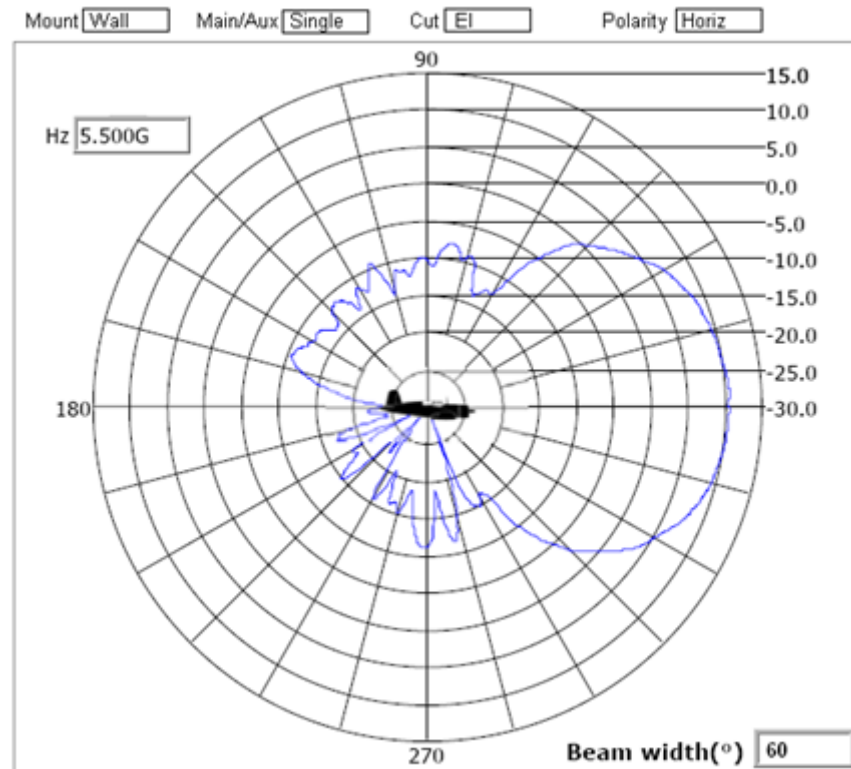

Port 2 Elevation Pattern

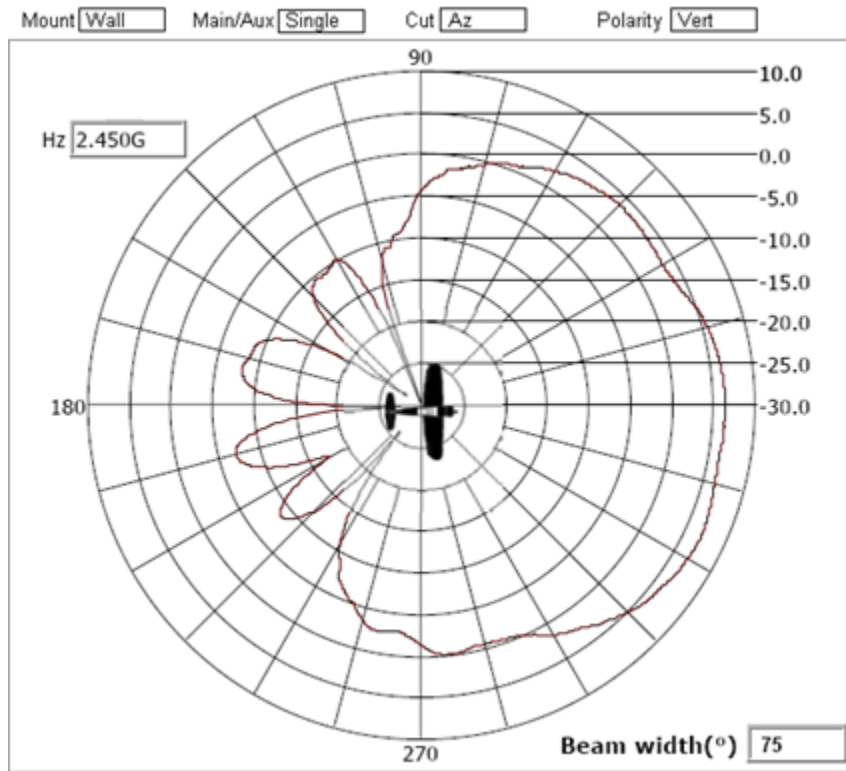

Port 3 Azimuth Pattern

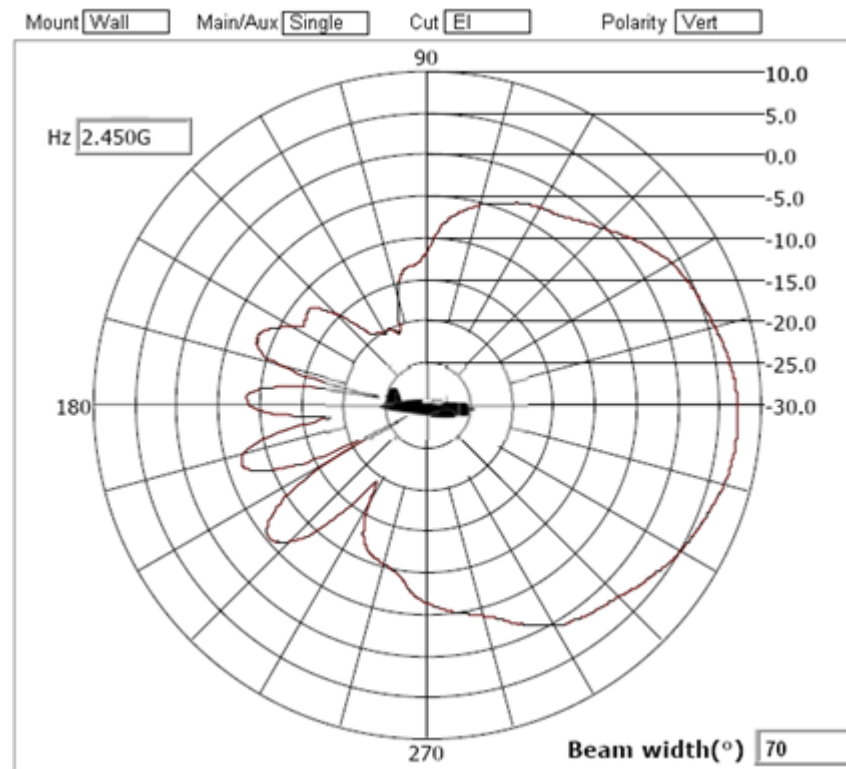

Port 3 Elevation Pattern

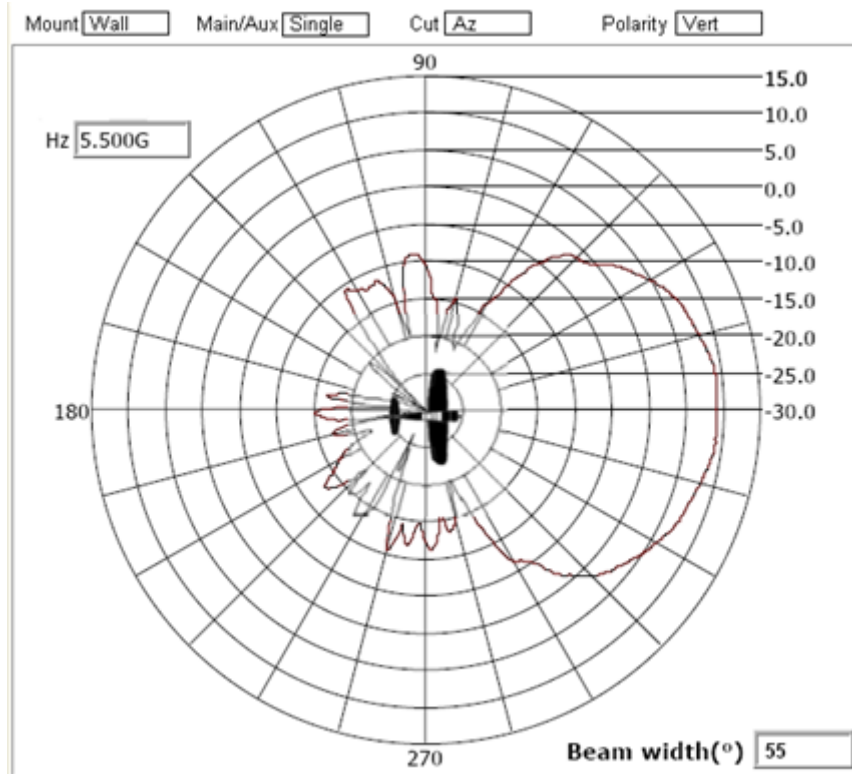

Port 3 Azimuth Pattern

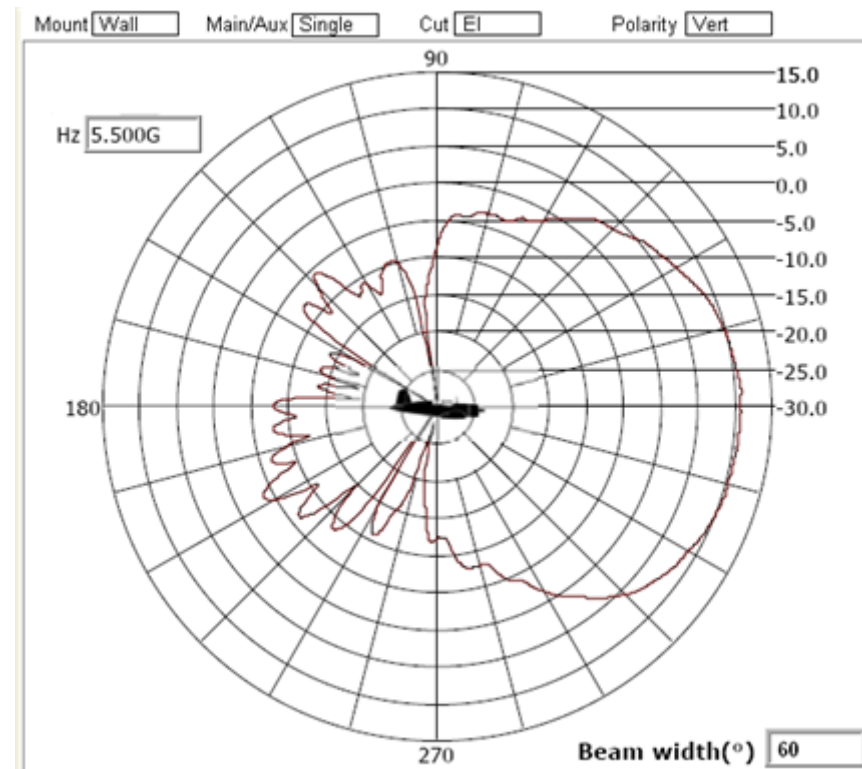

Port 3 Elevation Pattern

Antenna Cables

6.1 Supported Antenna Cables

Motorola supports numerous cables to suit your unique access point or access port deployment. Check the Motorola Web site periodically, as new cables will be added to this document as they are released. For more information, go to <http://support.symbol.com/support/product/manuals.do>.

For detailed information on supported cables, refer to:

- *ML-1499-100JK-01R 100 ft. Low-Loss Coaxial Cable Jumper: N Male to N Male with 2 Connector Seal Kits*
- *ML-1499-10JK-01R 10 ft. Low-Loss Coaxial Cable Jumper: N Male to N Male*
- *ML-1499-25JK-01R 25 ft. Low-Loss Coaxial Cable Jumper: N Male to N Male with 2 Connector Seal Kits*
- *ML-1499-50JK-01R 50 ft. Low-Loss Coaxial Cable Jumper: N Male to N Male with 2 Connector Seal Kits*
- *ML-1499-72PJ-01R 6 ft. RP BNC Female to RP BNC Male Plenum Coaxial Jumper*

6.1.1 ML-1499-100JK-01R 100 ft. Low-Loss Coaxial Cable Jumper: N Male to N Male with 2 Connector Seal Kits

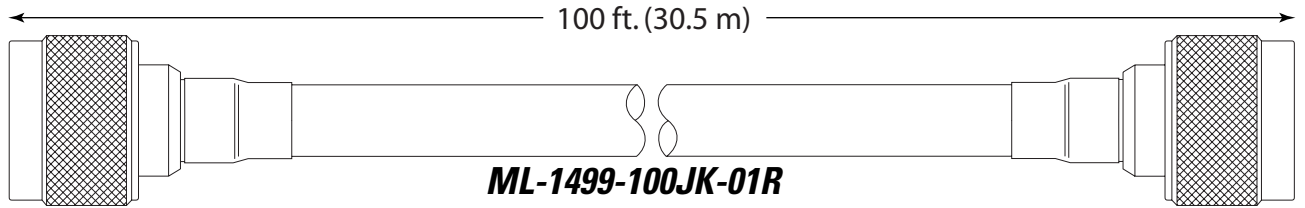

Type	Ultralink TL 93605
RF Connectors	N (m) to N (m)
Cable Attenuation (dB)	10.6 @ 2.4 GHz; 15.5 @ 5.8 GHz
Frequency	2 - 6 GHz

6.1.2 ML-1499-10JK-01R 10 ft. Low-Loss Coaxial Cable Jumper: N Male to N Male

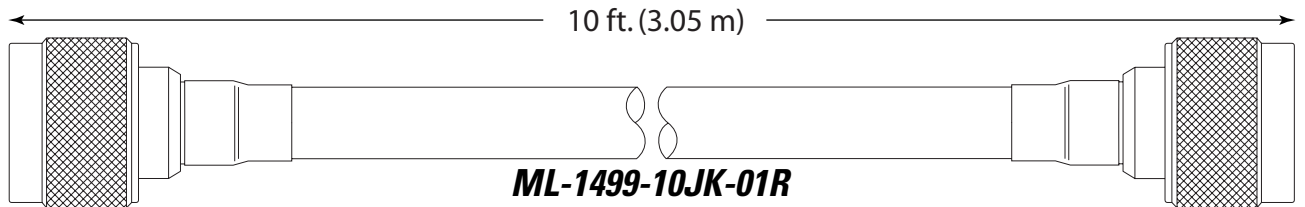

Type	Ultralink TL 93605
RF Connectors	N (m) to N (m)
Cable Attenuation (dB)	2.0 @ 2.4 GHz; 2.9 @ 5.8 GHz
Frequency	2 - 6 GHz

6.1.3 ML-1499-25JK-01R 25 ft. Low-Loss Coaxial Cable Jumper: N Male to N Male with 2 Connector Seal Kits

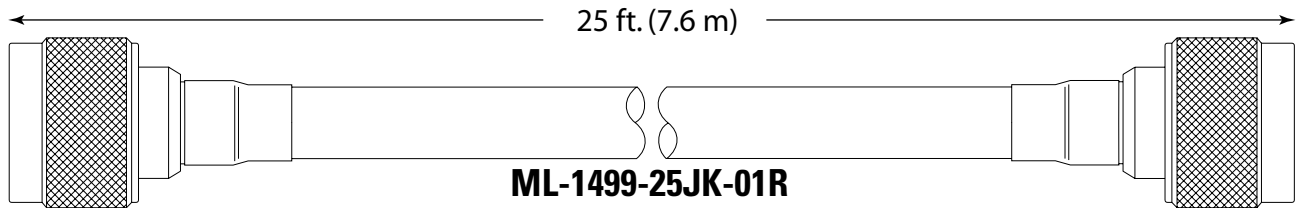

Type	Ultralink TL 93605
RF Connectors	N (m) to N (m)
Cable Attenuation (dB)	2.5 @ 2.4 GHz; 4.0 @ 5.8 GHz
Frequency	2 - 6 GHz

6.1.4 ML-1499-50JK-01R 50 ft. Low-Loss Coaxial Cable Jumper: N Male to N Male with 2 Connector Seal Kits

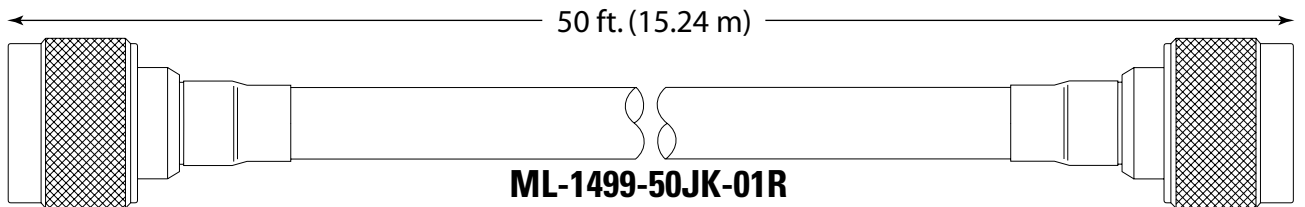

Type	Ultralink TL 93605
RF Connectors	N (m) to N (m)
Cable Attenuation (dB)	4.5 @ 2.4 GHz; 7.0 @ 5.8 GHz
Frequency	2 - 6 GHz

6.1.5 ML-1499-72PJ-01R 6 ft. RP BNC Female to RP BNC Male Plenum Coaxial Jumper

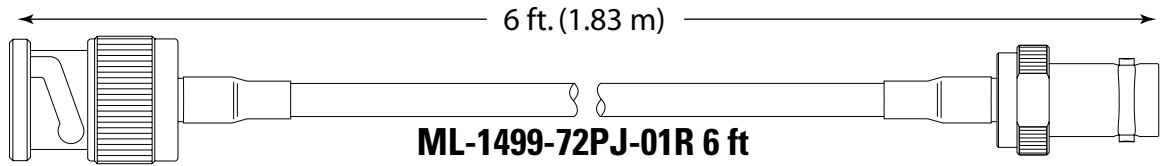

<i>Type</i>	CMP Plenum, RG-58
<i>RF Connectors</i>	RP BNC (f) to RP. BNC (m)
<i>Cable Attenuation (dB)</i>	2.3 dB
<i>Frequency</i>	2400-2500 Mhz

Supported Antenna Adapters

7.1 Supported Adapters

Motorola supports many adapters to suit your unique access point or access port deployment. Check the Motorola Web site periodically, as new adapters will be added to this document as they are released. For more information, go to <http://support.symbol.com/support/product/manuals.do>.

For detailed information on supported antenna adapters, refer to:

- *ML-1499-RBNCA1-01R 1 ft. N Female to RP BNC Female Cable Adapter with Connector Seal Kit*
- *ML-1499-RBNCA2-01R 1 ft. N Male to RP BNC Female Cable Adapter with Connector Seal Kit*
- *25-85391-01R 3.5 in. Jumper Cable, RP-SMA (Male) to Type N (Male) Adaptor*
- *25-85392-01R 3.5 in. Jumper Cable, RP-SMA (Male) to Type N (Female) Adaptor*
- *25-72178-01 Jumper, RP-SMA(M) to RP-BNC(F)*
- *25-90262-01R RP-SMA (Female) to Type N (Female) Adapter*
- *25-90263-01R Type N (Male) to RP-SMA (Female) Bulkhead Adapter*
- *25-97262-01R Connector for ML-2499-BYGA2-01R and AP300*
- *25-116485-01R Coax, RP-BNC(M) to N(F), 3.5 In.*
- *25-99175-01R Type N, Female to Female Adaptor*

7.1.1 ML-1499-RBNCA1-01R 1 ft. N Female to RP BNC Female Cable Adapter with Connector Seal Kit

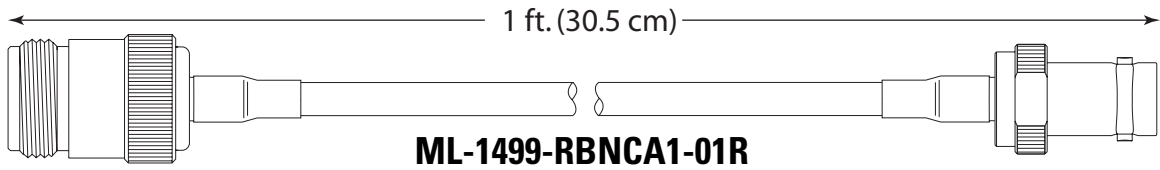

Type	Black, Ultralink, RG-58
RF Connectors	N (f) to RP. BNC (f)
Frequency	2400-2500 MHz
Attenuation	0.2 dB

7.1.2 ML-1499-RBNCA2-01R 1 ft. N Male to RP BNC Female Cable Adapter with Connector Seal Kit

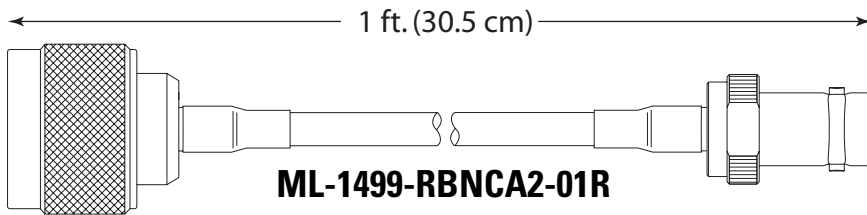

Type	RG-58
Frequency	2400-2500 MHz
Cable Loss (dB)	0.85 dB
Cable Length (in.)	12
Connector 1	N - Male
Connector 2	RP-BNC-F
Color	Black

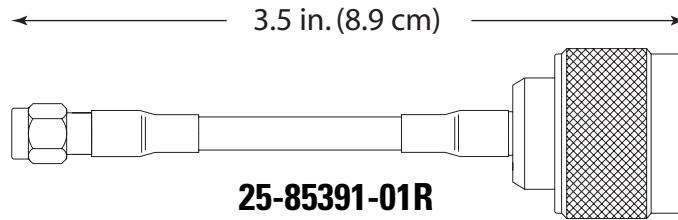
7.1.3 25-85391-01R 3.5 in. Jumper Cable, RP-SMA (Male) to Type N (Male) Adaptor

Type	Clear Jacket, RG-316
Connector 1	RP-SMA, Male
Connector 2	Type N, Male
Insertion Loss	2.4 GHz: 0.2 dB MIN
Insertion Loss	5.2 GHz: 0.3 dB MIN

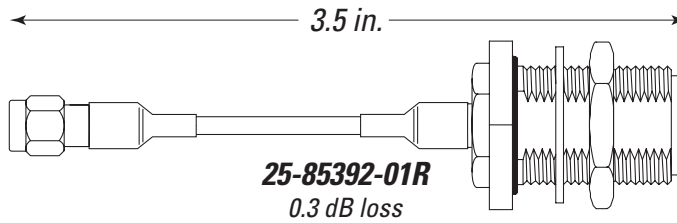
7.1.4 25-85392-01R 3.5 in. Jumper Cable, RP-SMA (Male) to Type N (Female) Adaptor

Type	Clear Jacket, RG-316
Connector 1	RP-SMA, Male
Connector 2	Type N, Female, Bulkhead
Insertion Loss	2.4 GHz: 0.2 dB MIN
Insertion Loss	5.2 GHz: 0.3 dB MIN

7.1.5 25-72178-01 Jumper, RP-SMA(M) to RP-BNC(F)

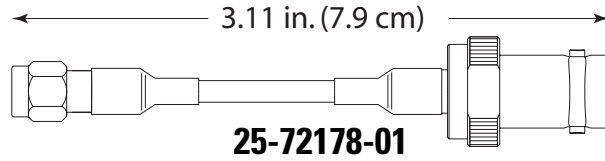

Type	RG-316
Connector 1	RP-SMA, Male
Connector 2	RP-BNC, Female
Insertion Loss	2.4 GHz: .2 dB
Insertion Loss	5.2 GHz: .3 dB

7.1.6 25-90262-01R RP-SMA (Female) to Type N (Female) Adapter

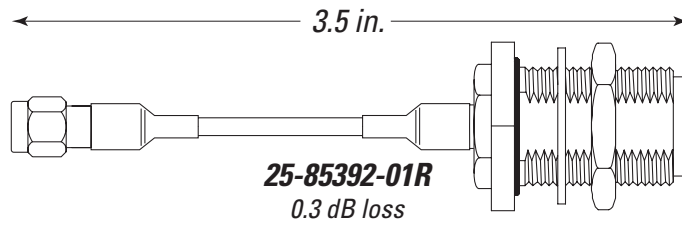

Type	RG-316
Connector 1	RP-SMA, Female, Bulkhead
Connector 2	Type N, Female, Bulkhead
Insertion Loss	2.4 GHz: .2 dB
Insertion Loss	5.2 GHz: .3 dB

7.1.7 25-90263-01R Type N (Male) to RP-SMA (Female) Bulkhead Adapter

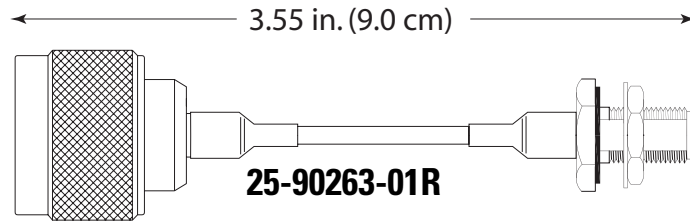

<i>Type</i>	RG-316
<i>Connector 1</i>	Type N, Male
<i>Connector 2</i>	RP-SMA, Female, Bulkhead
<i>Insertion Loss</i>	2.4 GHz: 0.2 dB MIN
<i>Insertion Loss</i>	5.2 GHz: 0.3 dB MIN

7.1.8 25-97262-01R Connector for ML-2499-BYGA2-01R and AP300

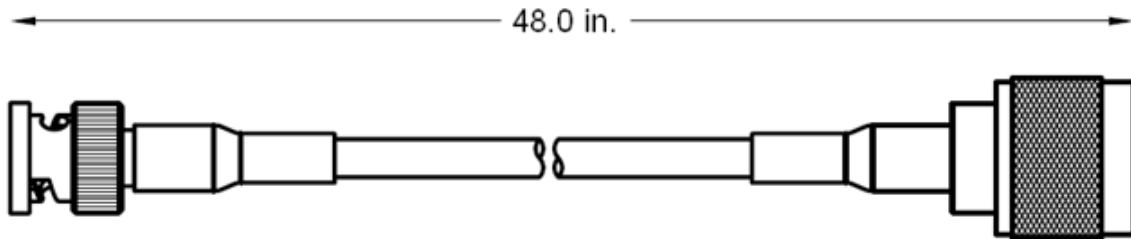

Type	RG-316
Frequency (MHz)	2400-2500
Connector 1	Type N, Male
Connector 2	RP-BNC-Male
Cable Loss (dB)	1.5
Cable Length (inches)	48
Color	Black

7.1.9 25-116485-01R Coax, RP-BNC(M) to N(F), 3.5 In.

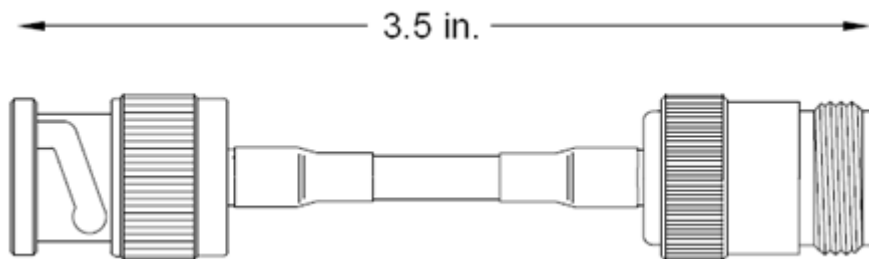

Type	RG-3 16/RG -174
Frequency (MHz)	2400-2500
Connector 1	RPBNC-Male
Connector 2	TYPE N -Female
Cable Loss (dB)	0.3
Cable Length (inches)	3.5

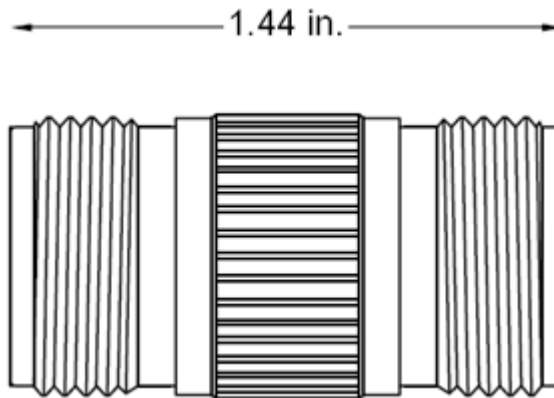
7.1.10 25-99175-01R Type N, Female to Female Adaptor

<i>Connector 1</i>	Type N, Female
<i>Connector 2</i>	Type N, Female
<i>Cable Loss (dB)</i>	0.3
<i>Cable Length (inches)</i>	1.44

Supported Lightning Arrestors

8.1 Lightning Arrestors

Motorola supports several lightning arrestors to support your unique access point or access port deployment safety requirements. Check the Motorola Web site periodically, as new lightning arrestors will be added to this document as they are released. For more information, go to <http://support.symbol.com/support/product/manuals.do>.

For detailed information on supported lightning arrestors refer to:

- *ML-1499-LAK1-01R 1 ft. N Male to RP BNC Male Lightning Arrestor with Connector Seal Kit*
- *ML-1499-LAK2-01R Lightning Arrestor Kit with N Male to N Male Barrel Adapter*
- *ML-2452-LAK1-01R Lightning Arrestor (N Female to N Female) with N Male to RP-SMA Male Adapter*



WARNING! The grounding lug on a lightning arrestor must be grounded in compliance with local electrical codes.

8.1.1 ML-1499-LAK1-01R 1 ft. N Male to RP BNC Male Lightning Arrestor with Connector Seal Kit

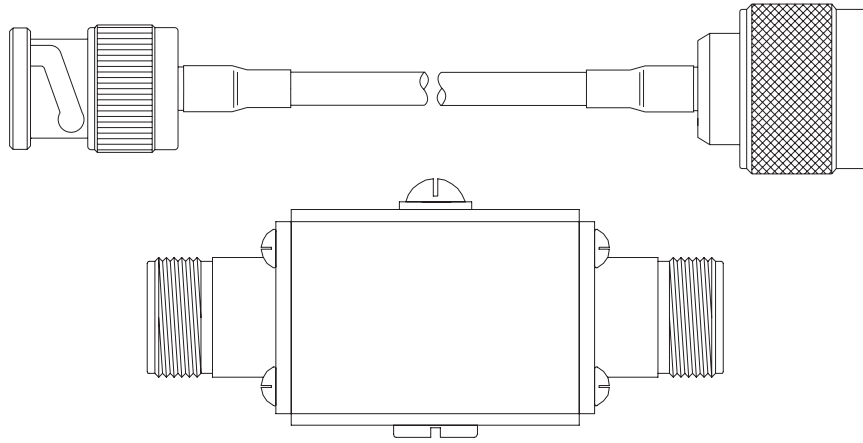

ML-1499-LAK1-01R

<i>Cable</i>	Black, Ultralink, RG-58
<i>RF Connectors</i>	N (m) to RP. BNC (m)
<i>Arrestor RF Connectors</i>	N (f) to N (f)
<i>Frequency</i>	2400-2500 MHz
<i>Insertion Loss - Lightning Arrestor</i>	0.25 dB @ 2.4 GHz
<i>Insertion Loss - Cable</i>	0.6 dB @ 2.4 GHz



NOTE: Not for use above 2500 MHz.

8.1.2 ML-1499-LAK2-01R Lightning Arrestor Kit with N Male to N Male Barrel Adapter

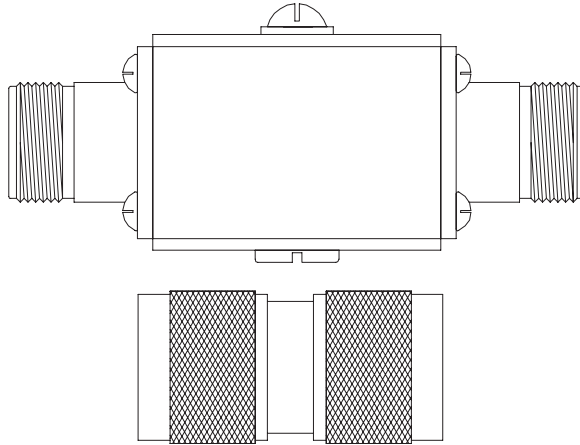

ML-1499-LAK2-01R

<i>RF Connectors</i>	N (m) to N (m)
<i>Arrestor RF Connectors</i>	N (f) to N (f)
<i>Frequency</i>	2400-2500 MHz
<i>Maximum RF Power</i>	100 W
<i>Insertion Loss - Lightning Arrestor</i>	0.25 dB @ 2.4 GHz / 14 dB @ 5.5GHz



NOTE: Not for use above 2500 MHz.

8.1.3 ML-2452-LAK1-01R Lightning Arrestor (N Female to N Female) with N Male to RP-SMA Male Adapter

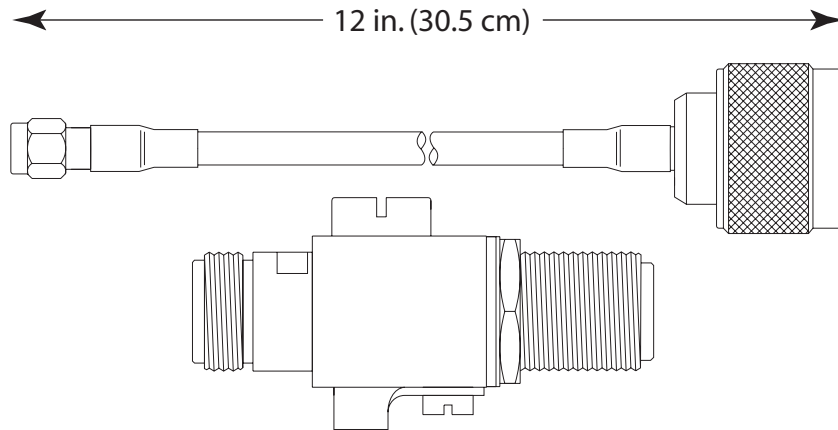

ML-2452-LAK1-01R

<i>Cable</i>	Black, Ultralink, RG-58
<i>Connectors - Cable</i>	N (m) to RP. SMA (m)
<i>Frequency</i>	100-6000 MHz
<i>Insertion Loss - Cable</i>	0.6 @ 2.4 GHz, 1.4 @ 5.5 GHz
<i>Insulation Resistance</i>	50 M-ohms
<i>Connectors - Lightning Arrestor</i>	Type N (f) to N (f)
<i>Weight</i>	4.5 oz
<i>Operating Temperature</i>	- 40° to 85°C
<i>Insertion Loss - Lightning Arrestor</i>	0.14 @ 2.4 GHz, 0.35 @ 5.5 GHz

Mounting Kits

9.1 Mounting Kit Support

Motorola supports mounting kits to support your unique access point or access port deployment. Check the Motorola Web site periodically, as new kits will be added to this document as they are released. For more information, go to <http://support.symbol.com/support/product/manuals.do>.

For detailed information on supported mounting kits refer to:

-
- *[ML-1499-SD3MK-01R Articulating I-Beam Mount Kit for ML-2499-SD3-01 Omni Antenna](#)*

9.1.1 ML-1499-APAMK-01R Magnetic Base for ML-2452-APA2-01 with 6 Ft. Cable RP-SMA (Male)

 **NOTE:** The dimensions displayed for the ML-1499-APAMK-01R mounting kit in the illustration below are in millimeters (mm).

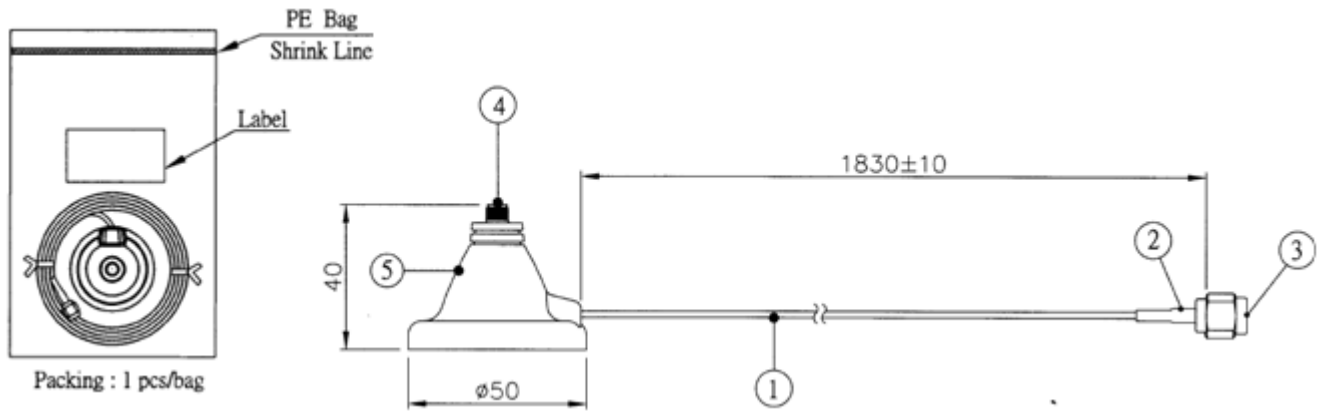

Cable	RG-178
Connector 3	RP-SMA, Male
Connector 4	RP-SMA, Female
Attenuation (dB)	2.6 @ 2.4 GHz; 4.6 @ 5.5 Ghz

9.1.2 ML-1499-SD3MK-01R Articulating I-Beam Mount Kit for ML-2499-SD3-01 Omni Antenna

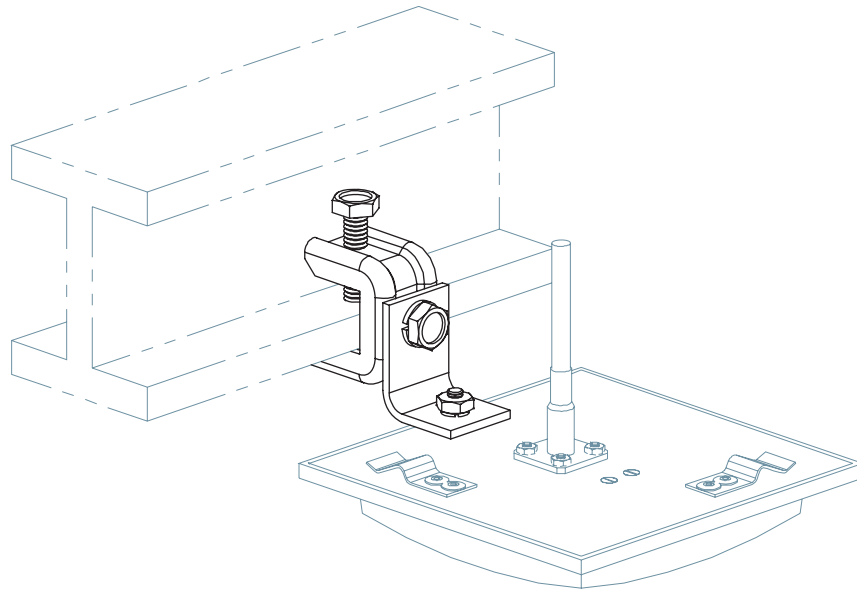

<i>Functionality</i>	Mounts Part No. ML-2499-SD3-01 to an I-beam.
----------------------	----------------------------------------------

AP-5131 Antenna Connections

This chapter describes how the 2.4 and 5 GHz antennas described within this guide are physically connected to an AP-5131 model access point. Central in this discussion are descriptions of the single and dual-band antennas supported, their supported connector models and how lightning arrestors are supported for specific antenna and connector combinations. For more information, see:

- [2.4 GHz AP-5131 Antenna Connections](#)
- [5 GHz AP-5131 Antenna Connections](#)

P/N	Length	Conn 1	Conn 2	Attn 2.4	Attn 5.5
25-72178-01	3.1 in.	RSMA-m	RBNC-f	0.2	N/A
25-85391-01R	3.5 in.	RSMA-m	N-m	0.2	0.3
25-85392-01R	3.5 in.	RSMA-m	N-f bulkhead	0.2	0.3
25-90262-01R	3.55 in.	RSMA-f	N-f bulkhead	0.2	0.3
25-90263-01R	3.55 in.	RSMA-f	N-m	0.2	0.3
25-97261-01R	48 in.	N-m	RBNC-m	1.5	N/A
25-99175-01R	1.5 in.	N-f	N-f	0.2	0.3
ML-1499-100JK-01R	100 ft	N-m	N-m	10.6	15.5
ML-1499-10JK-01R	10 ft	N-m	N-m	2	2.9
ML-1499-25JK-01R	25 ft	N-m	N-m	2.5	4
ML-1499-50JK-01R	50 ft	N-m	N-m	4.5	7
ML-1499-72PJ-01R	6 ft	RPBNC-f	RBNC-m	2.3	N/A
ML-1499-LAK1 Cable	12 in.	N-m	RBNC-m	0.6	N/A
ML-1499-LAK1/2 Arrestor	2.25 in.	N-f	N-f	0.24	N/A
ML-1499-LAK2 Adapter	1.5 in.	N-m	N-m	0.15	N/A
ML-1499-RBNCA1-01R	1 ft	N-f	RBNC-f	0.85	N/A
ML-1499-RBNCA2-01R	1 ft	N-m	RBNC-f	0.85	N/A
ML-2452-LAK1 Arrestor	1.75 in.	N-m	N-m	0.14	0.35
ML-2452-LAK1 Cable	12 in.	N-m	RSMA-m	0.6	1.4



CAUTION: The installation of lightning arrestors (as described in several of the AP-5131 antenna connection scenarios in this chapter) must meet local electrical codes.

10.1 2.4 GHz AP-5131 Antenna Connections

This section describes how the components described within this guide are used collectively in the following AP-5131 installation scenarios supporting the 2.4 GHz band:

- [RP-BNC Male Antenna Installation](#)
- [Type N Male Connector Installation](#)



NOTE: For information on the individual 2.4 GHz antennas approved for use with an AP-5131, see [2.4 GHz Single Band Antenna Suite](#).

10.1.1 RP-BNC Male Antenna Installation

Refer to the following for a graphical depiction of the parts and connection options available for cabling an 2.4 GHz AP-5131 model access point using RP-BNC male antennas:

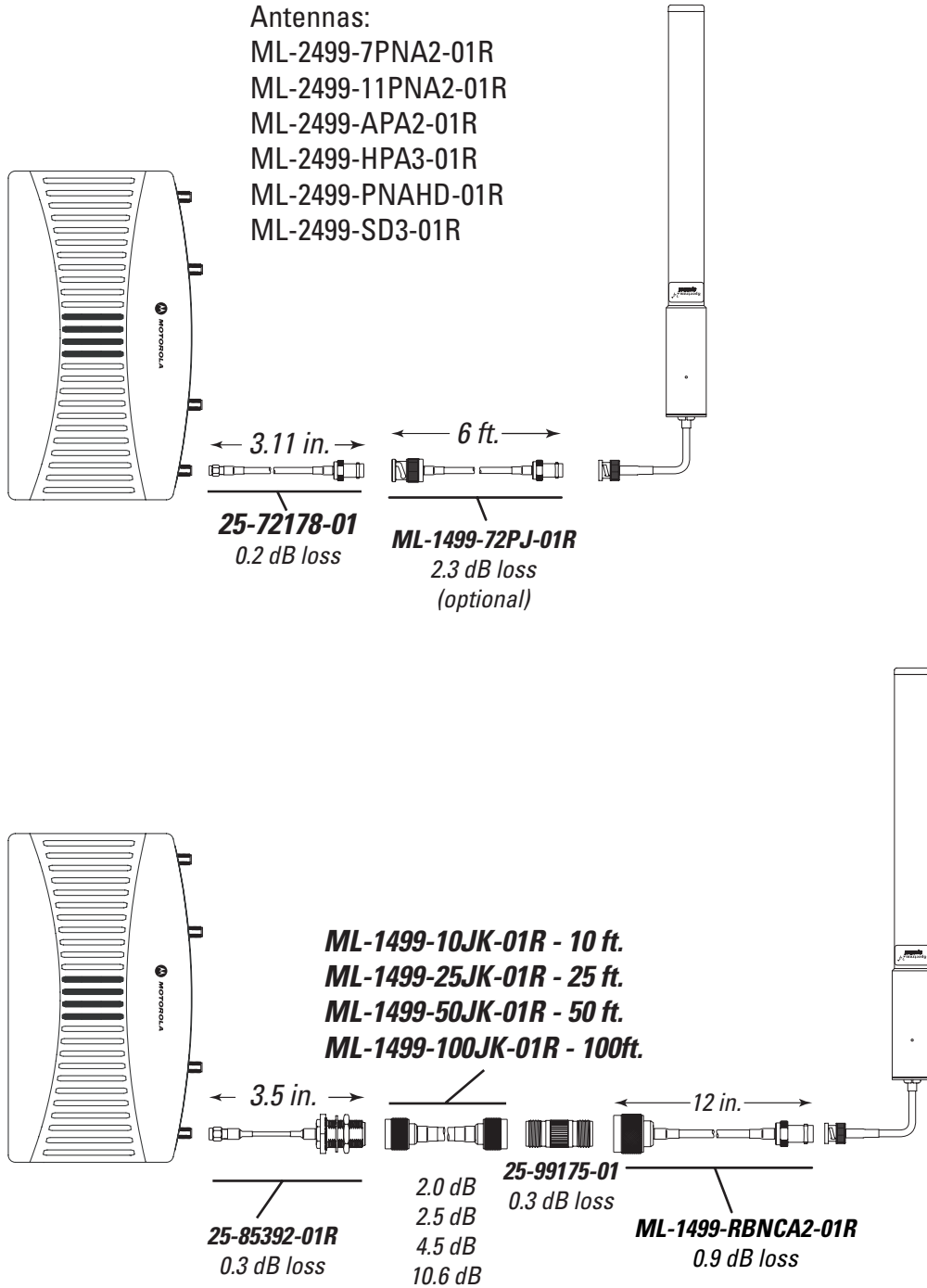

Lightning Aresstor, Antenna side

Antennas:
 ML-5299-PTA1-01R
 ML-5299-WPNA1-01R
 ML-5299-HPA1-01R

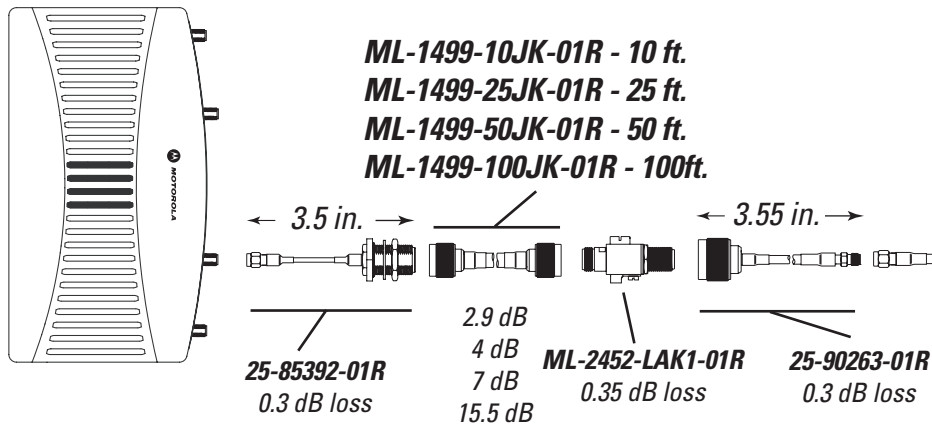

Lightning Aresstor, AP side

Antennas:
 ML-5299-PTA1-01R
 ML-5299-WPNA1-01R
 ML-5299-HPA1-01R

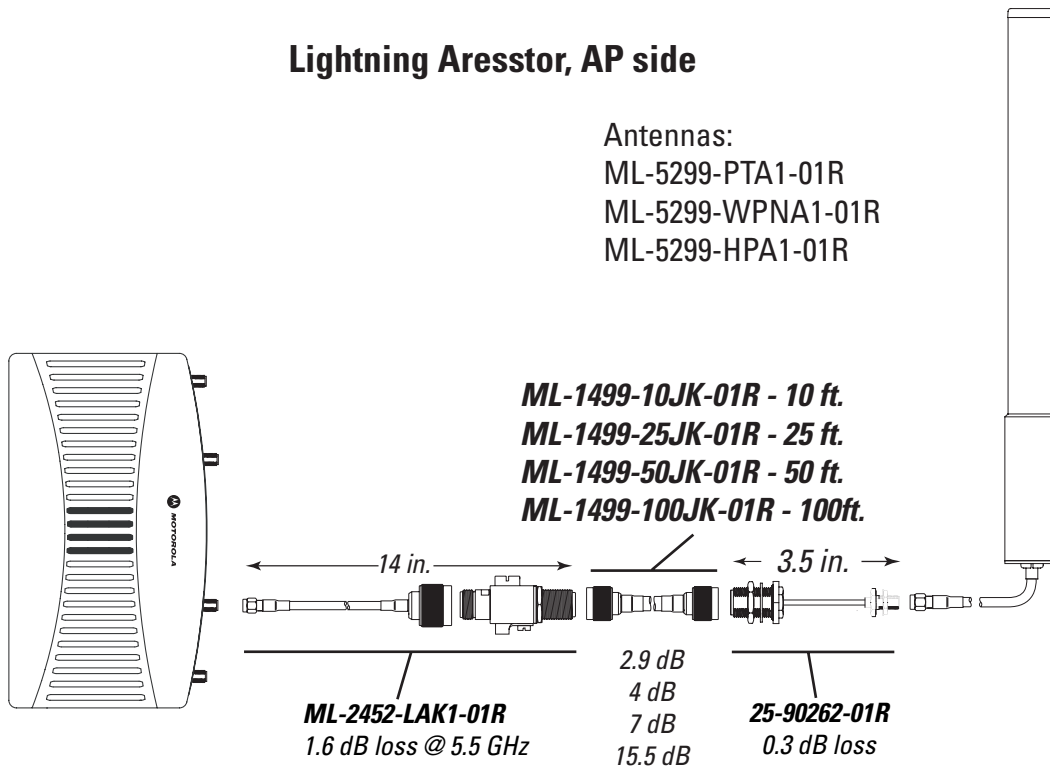

10.1.2 Type N Female Connector Installation

Refer to the following for a graphical depiction of the parts and connection options available for cabling an 2.4 GHz AP-5131 model access point using Type N female connectors:

Antennas:
 ML-2499-BPDA1-01R
 ML-2499-BPNA3-01R
 ML-2499-BYGA2-01R

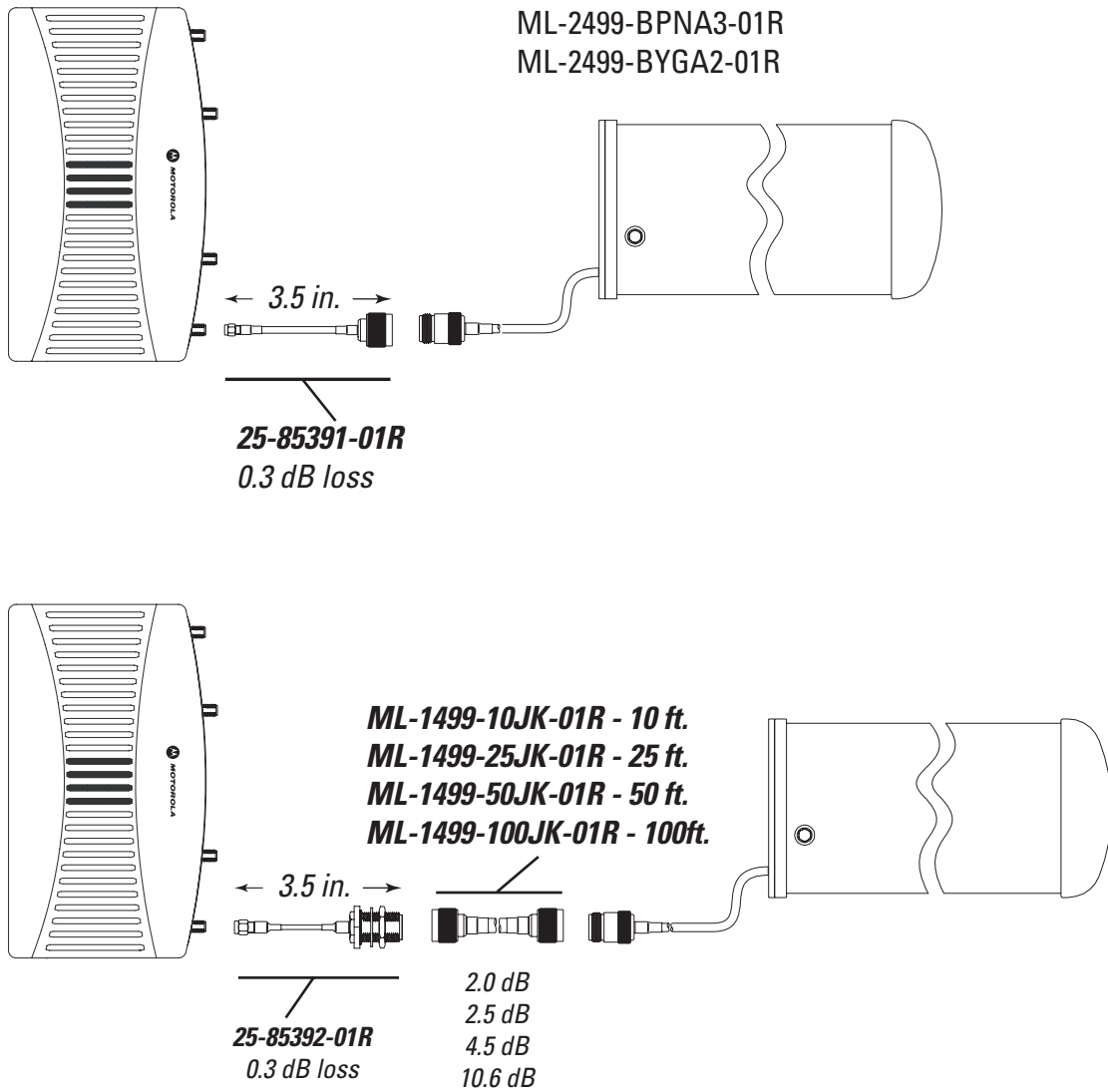

 **CAUTION:** The minimum cable configuration is required to meet regulatory requirements.

Lightning Aresstor, Antenna side

Antennas:
 ML-2499-BPDA1-01R
 ML-2499-BPNA3-01R
 ML-2499-BYGA2-01R

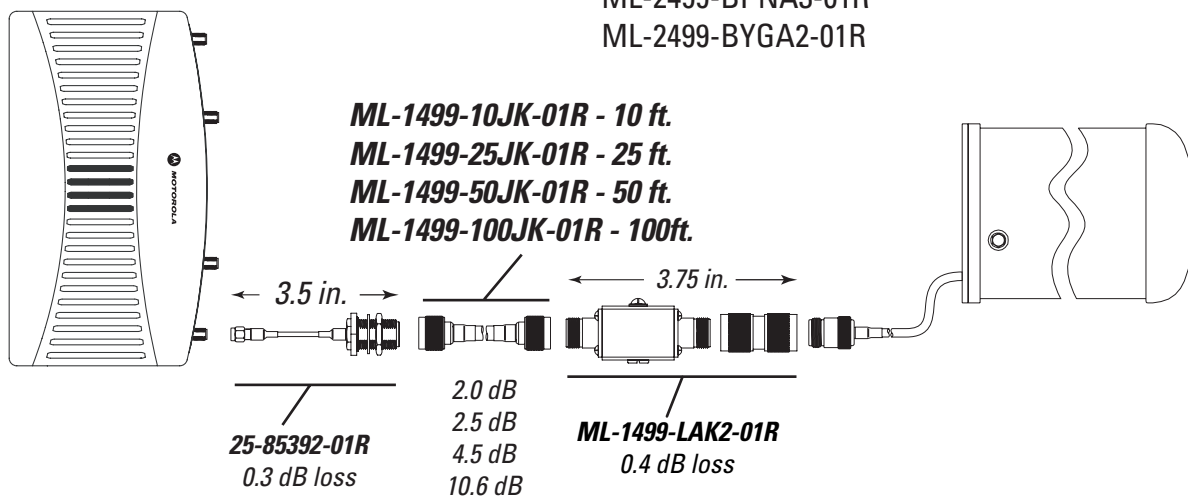

Lightning Aresstor, AP side

Antennas:
 ML-2499-BPDA1-01R
 ML-2499-BPNA3-01R
 ML-2499-BYGA2-01R

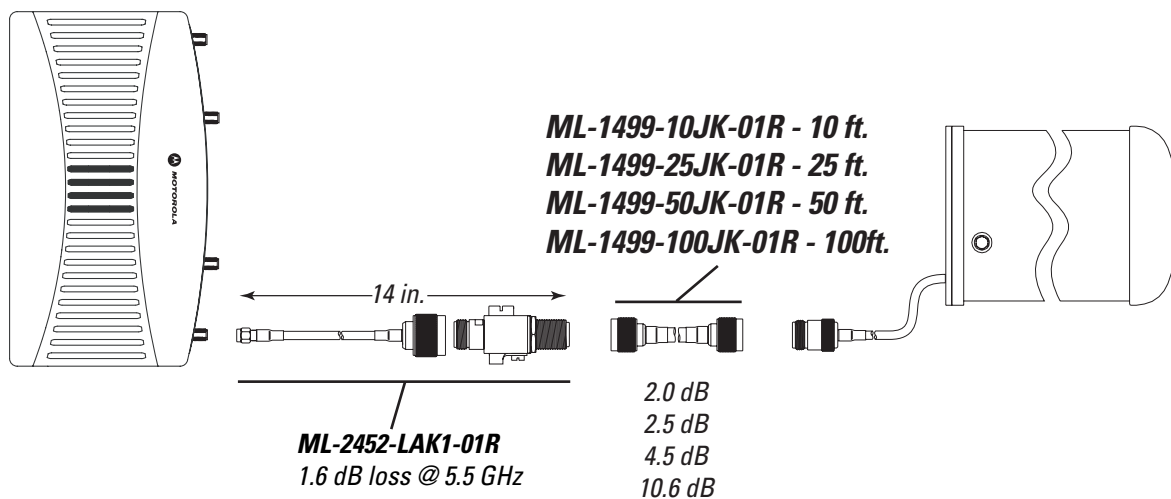

10.1.3 Type N Male Connector Installation

Refer to the following for a graphical depiction of the parts and connection options available for cabling an 2.4 GHz AP-5131 model access point using Type N male connectors:

Antennas:
 ML-2499-5PNL-72-N
 ML-2499-FHPA5-01R
 ML-2499-FHPA9-01R

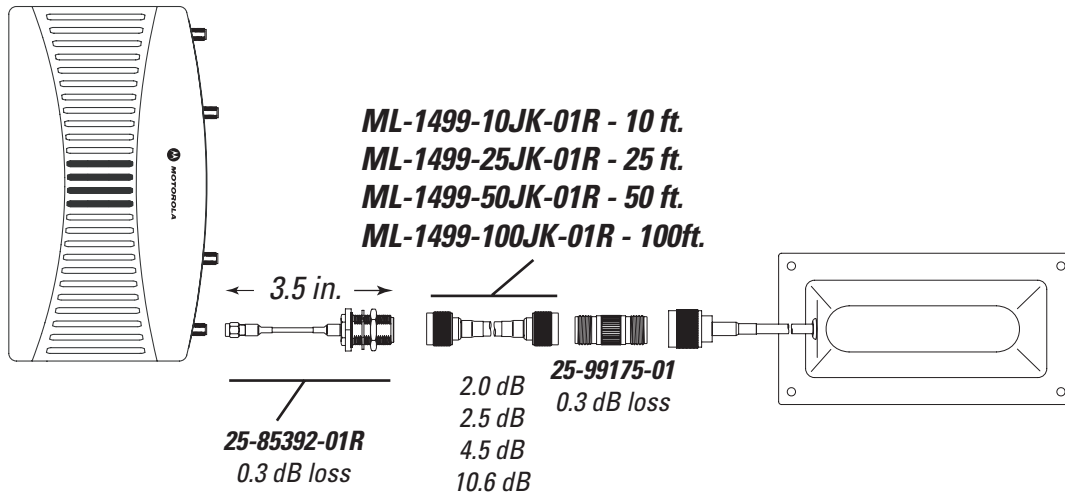

Antennas:
 ML-2499-5PNL-72-N
 ML-2499-FHPA5-01R
 ML-2499-FHPA9-01R

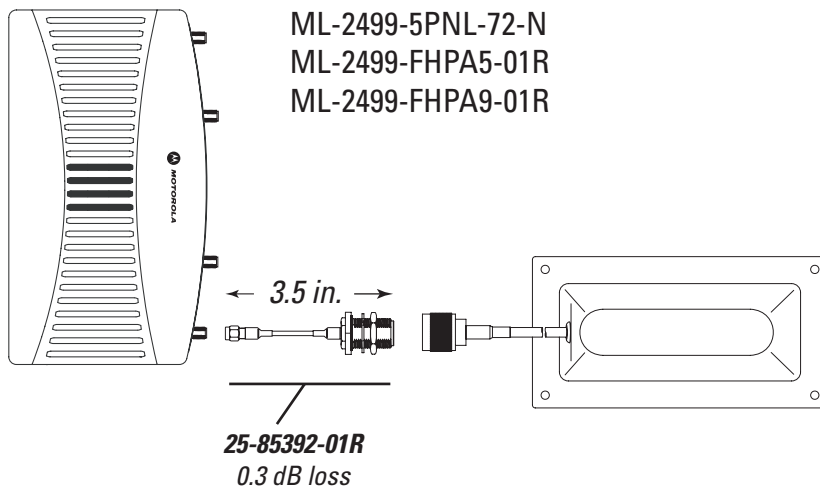

Antennas:
ML-2499-HPA3-01R

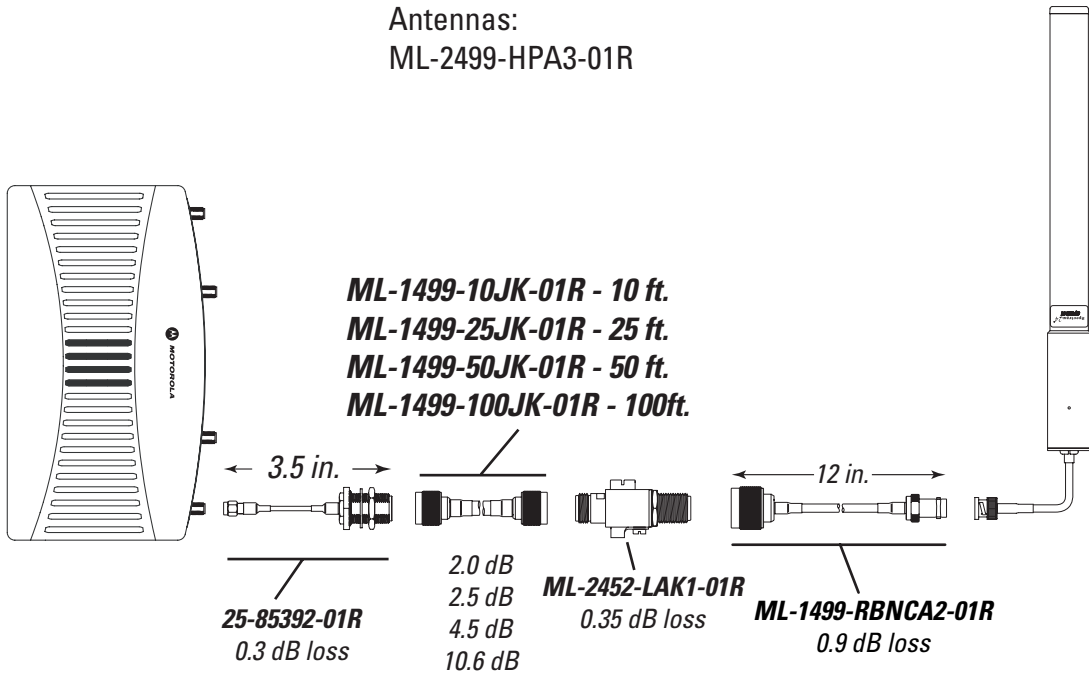

Lightning Arrestor, AP side

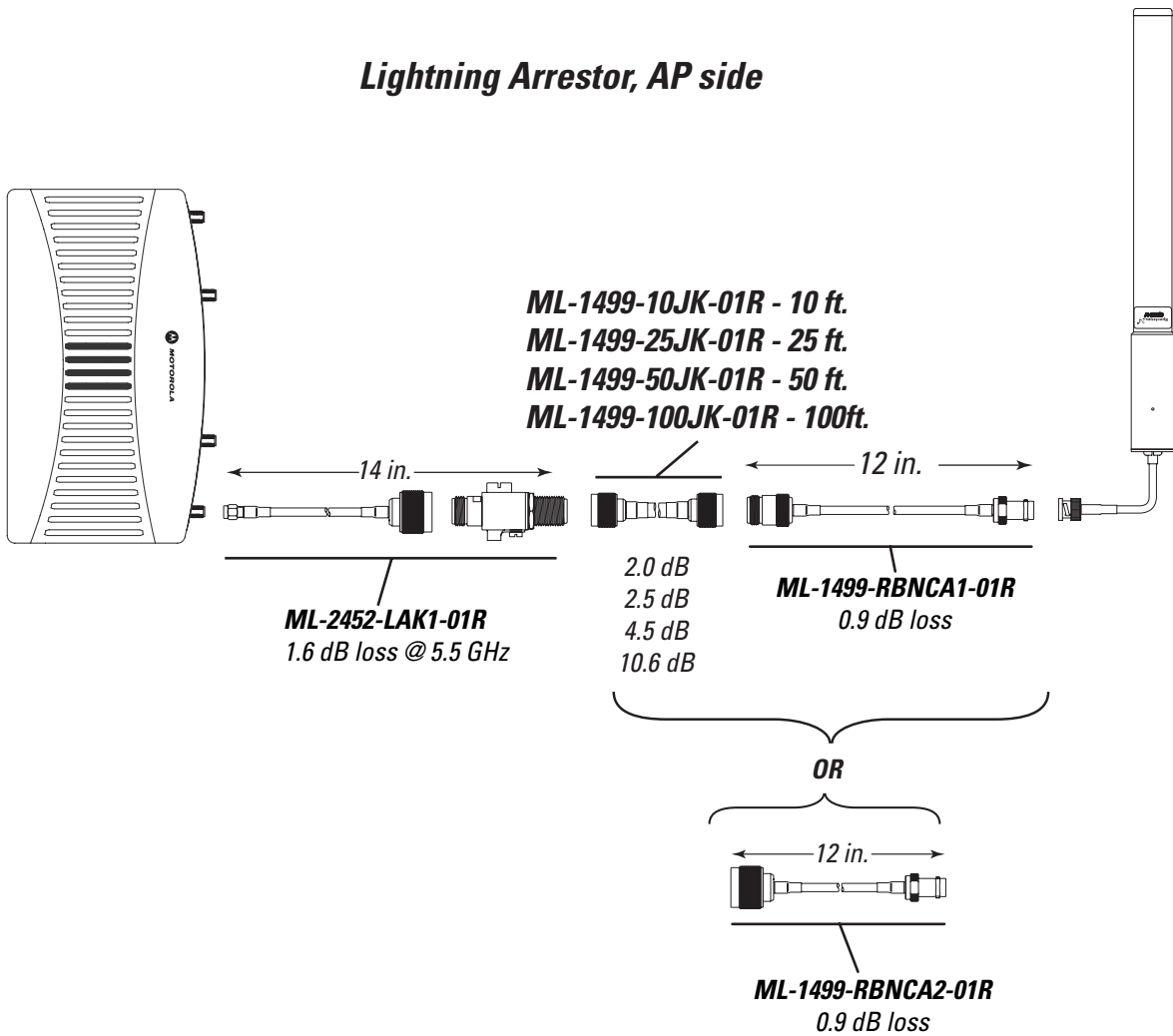

10.2 5 GHz AP-5131 Antenna Connections

This section describes how the components described within this guide are used collectively in the following AP-5131 installation scenarios supporting the 5 GHz band:

- [RP-SMA Male Antenna Installation](#)
- [Type N Male Connector Installation](#)



NOTE: For information on the individual 5 GHz antennas approved for use with an AP-5131, see [5.2 Ghz Single Band Antenna Suite](#).

10.2.1 RP-SMA Male Antenna Installation

Refer to the following for a graphical depiction of the parts and connection options available for cabling an 5 GHz AP-5131 model access point using a RP-SMA male antenna (with no lightning arrestor):

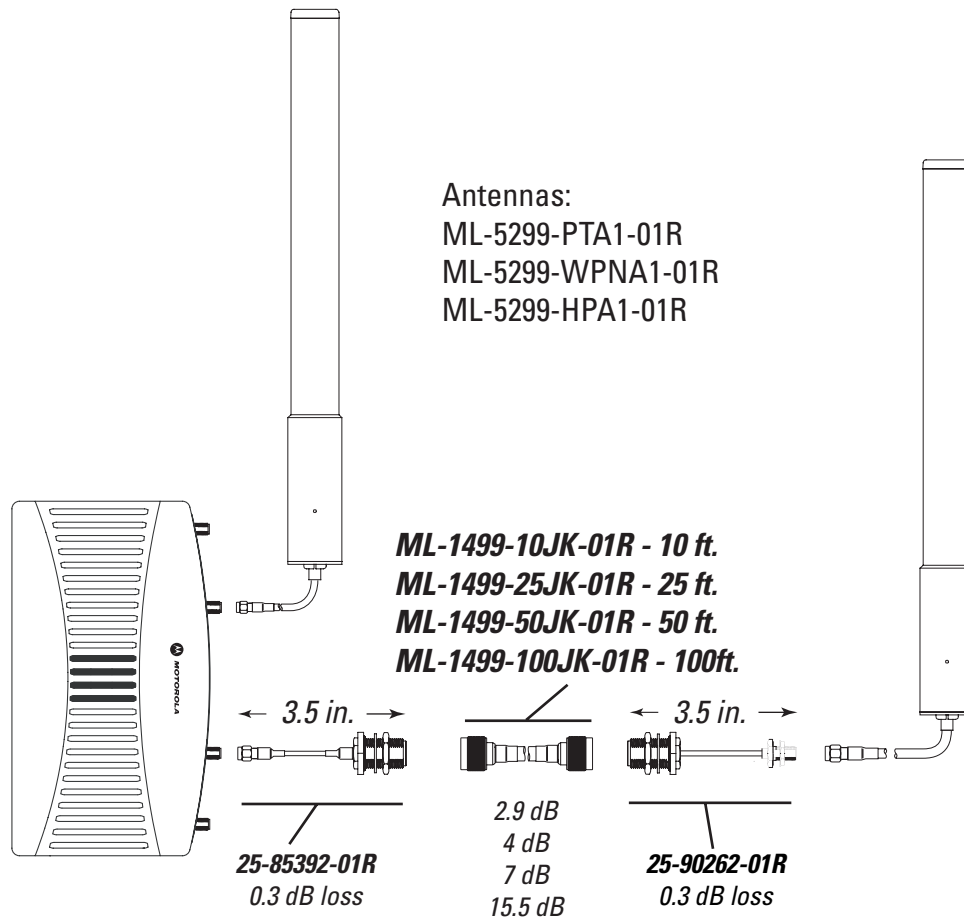

Refer to the following for a graphical depiction of the parts and connection options available for cabling an 5 GHz AP-5131 model access point using a RP-SMA male antenna (with a lightning arrestor):

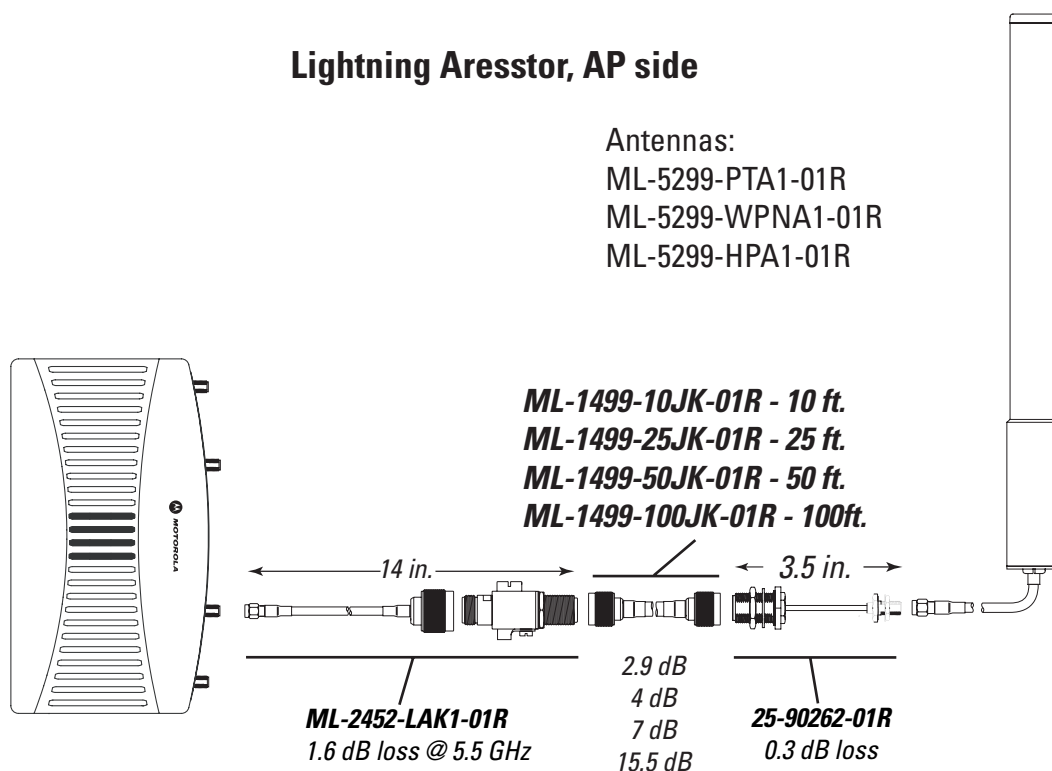
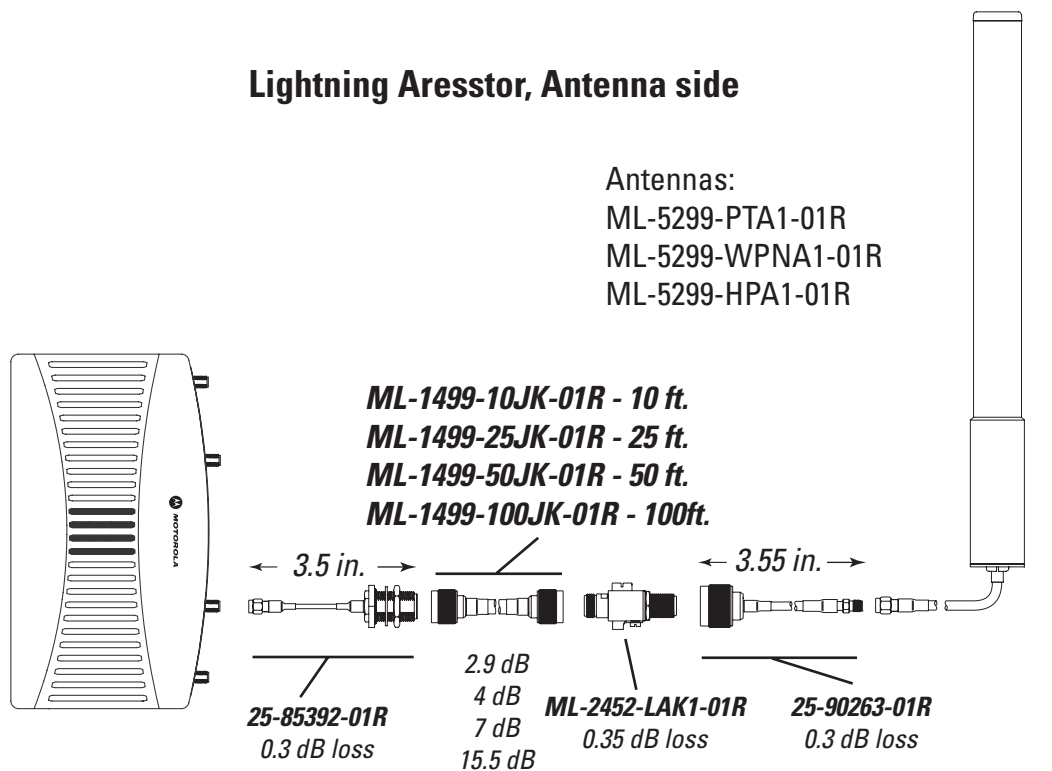

10.2.2 Type N Male Connector Installation

Refer to the following for a graphical depiction of the parts and connection options available for cabling an 5 GHz AP-5131 model access point using Type N male connectors:

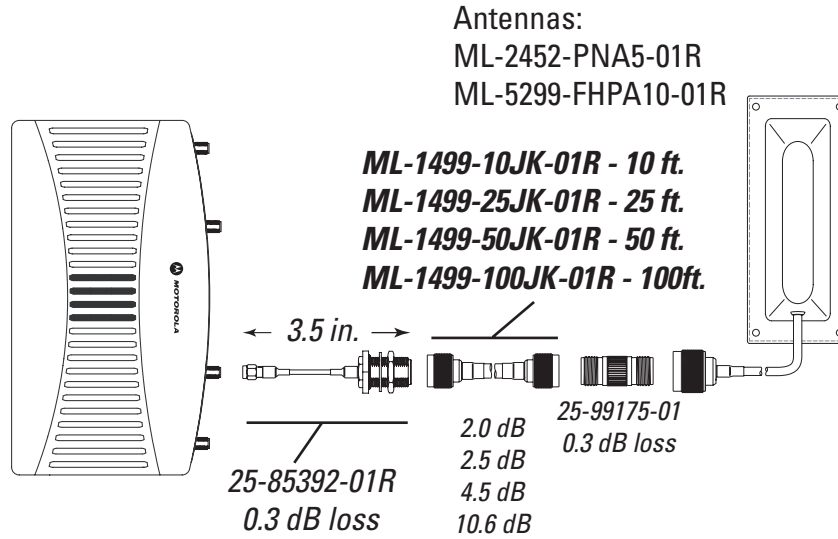

Lightning Aresstor, Antenna side

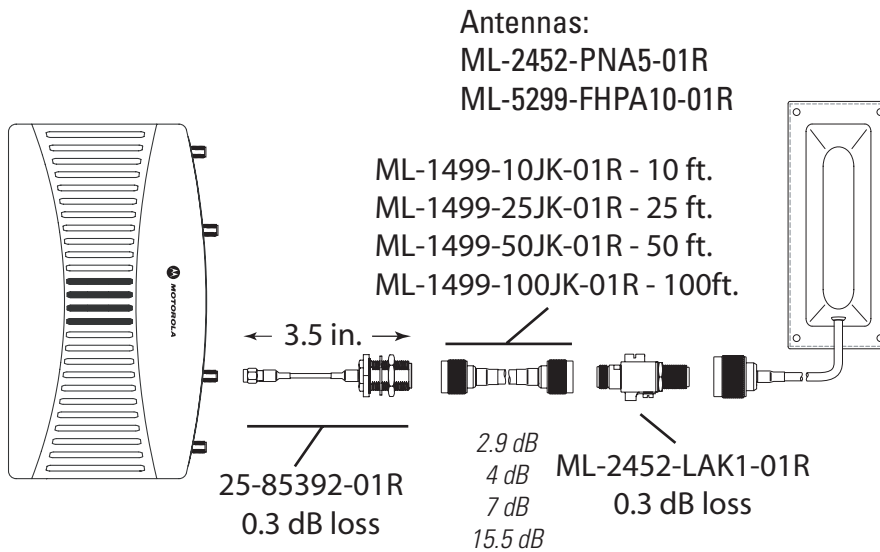

Lightning Aresstor, AP side

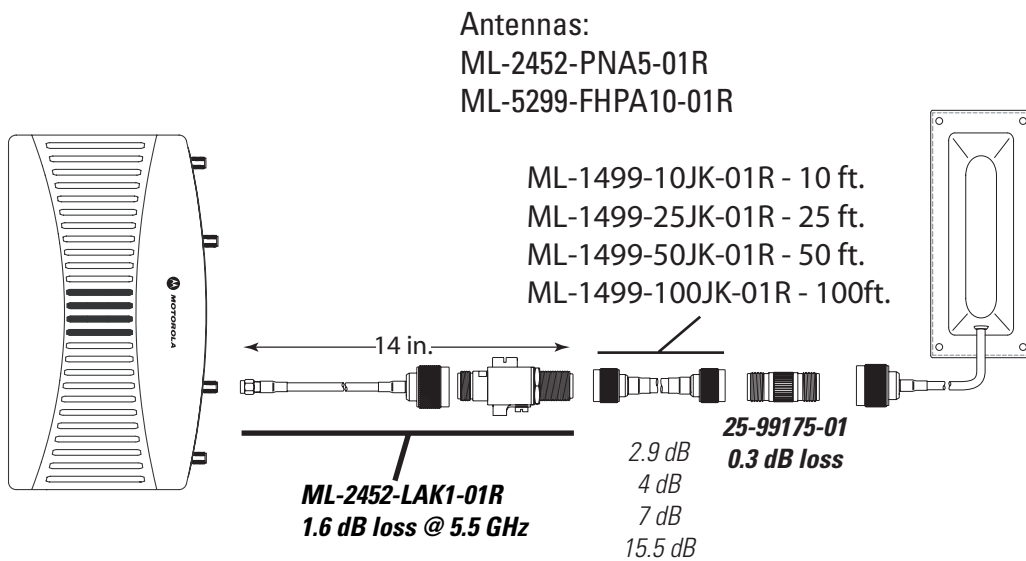

AP300 Antenna Connections

This chapter describes how the 2.4 and 5 GHz antennas described within this guide are physically connected to an AP300 model access port. The information in this chapter supports an AP300 external antenna model only.



CAUTION: The installation of lightning arrestors (as described in several of the AP300 antenna connection scenarios in this chapter) must meet local electrical codes.

For more information, see:

- [2.4 GHz AP300 Antenna Connections](#)
- [5 GHz AP300 Antenna Connections](#)

11.1 2.4 GHz AP300 Antenna Connections

This section describes how the components described within this guide are used collectively in the following AP300 installation scenarios supporting the 2.4 GHz band:

- [RP-BNC Male Antenna Installation](#)
- [Type N Female Connector Installation](#)
- [Type N Male Connector Installation](#)

11.1.1 RP-BNC Male Antenna Installation

Refer to the following for a graphical depiction of the parts and connection options available for cabling an 2.4 GHz AP300 model access port using RP-BNC male antennas:

Antennas:

- ML-2499-7PNA2-01R
- ML-2499-11PNA2-01R
- ML-2499-APA2-01R
- ML-2499-HPA3-01R
- ML-2499-PNAHD-01R
- ML-2499-SD3-01R

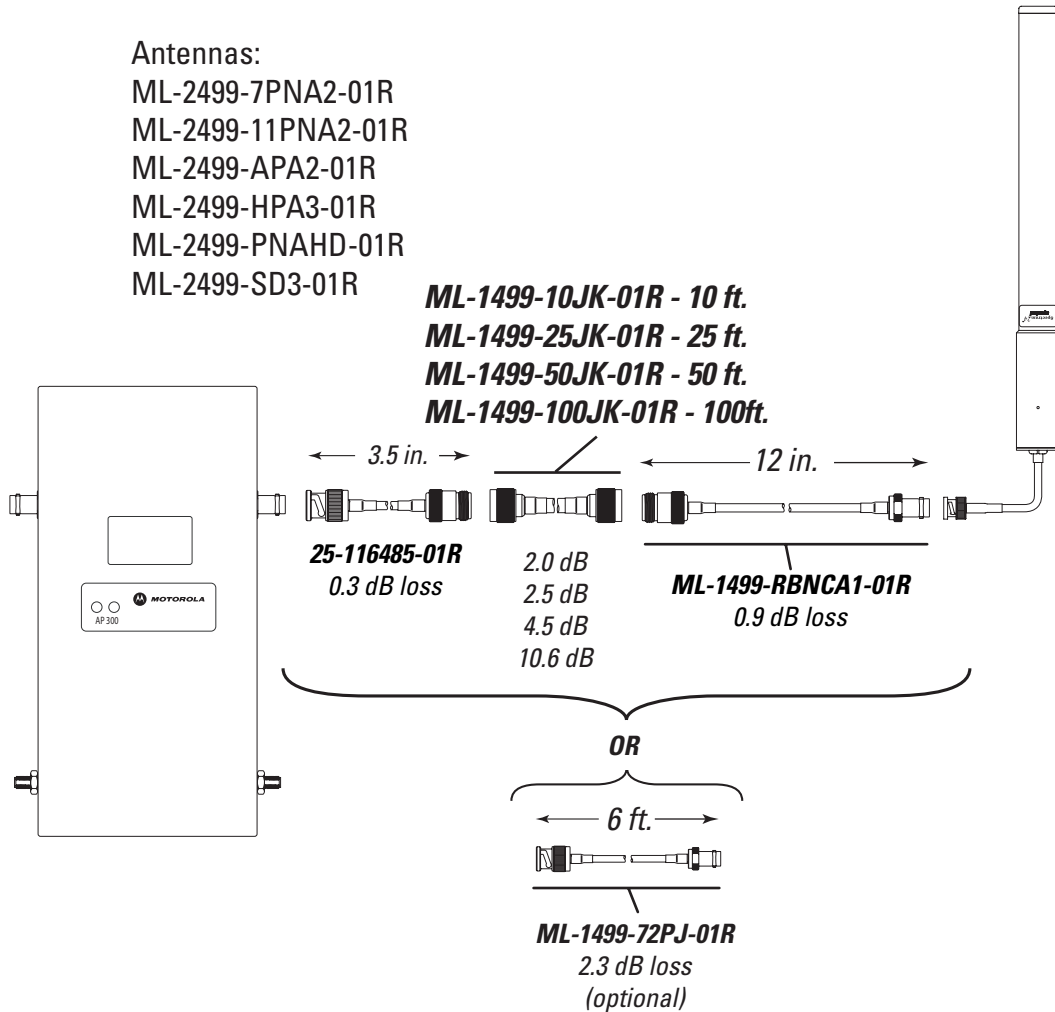

Lightning Arrestor, Antenna side

Antennas:
ML-2499-HPA3-01R

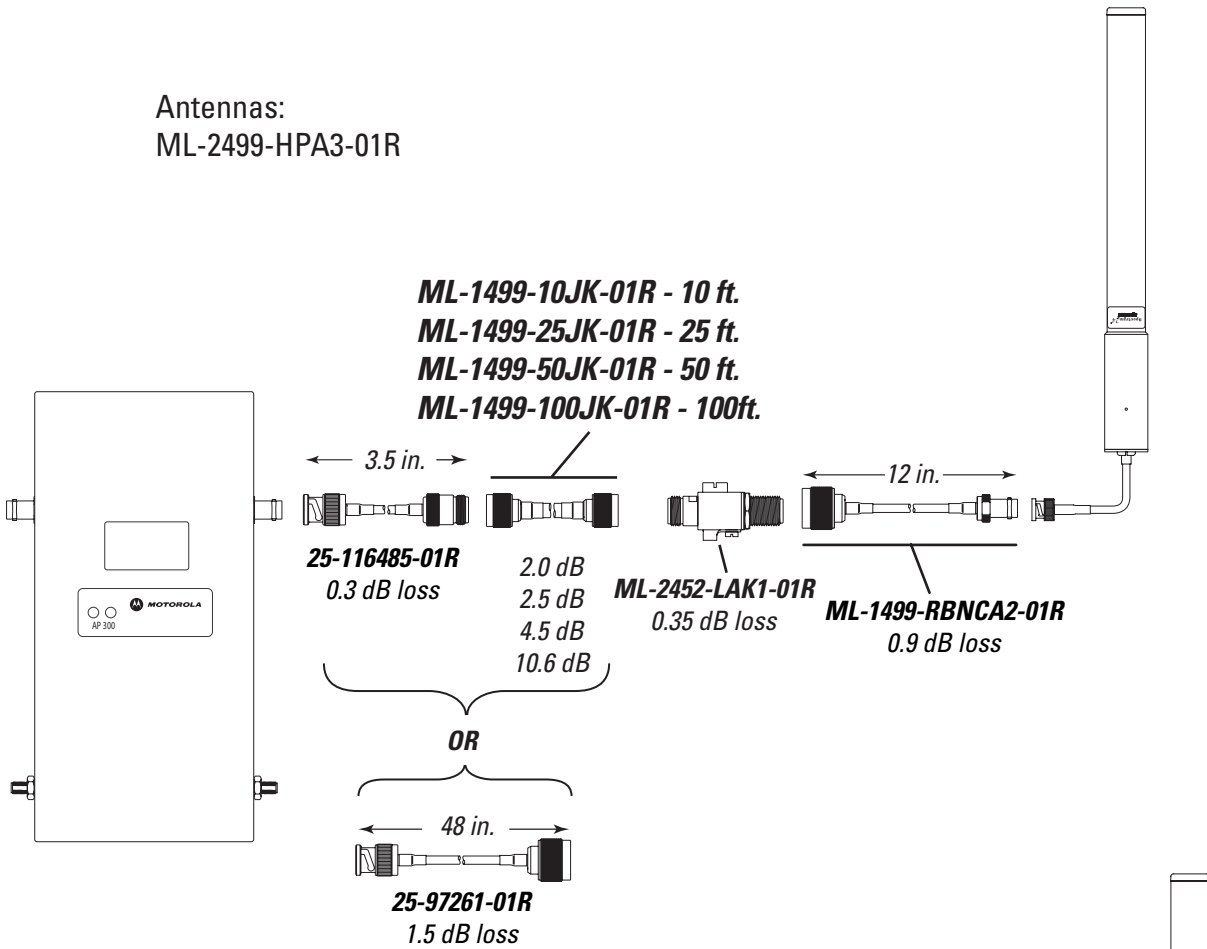

Lightning Arrestor, AP side

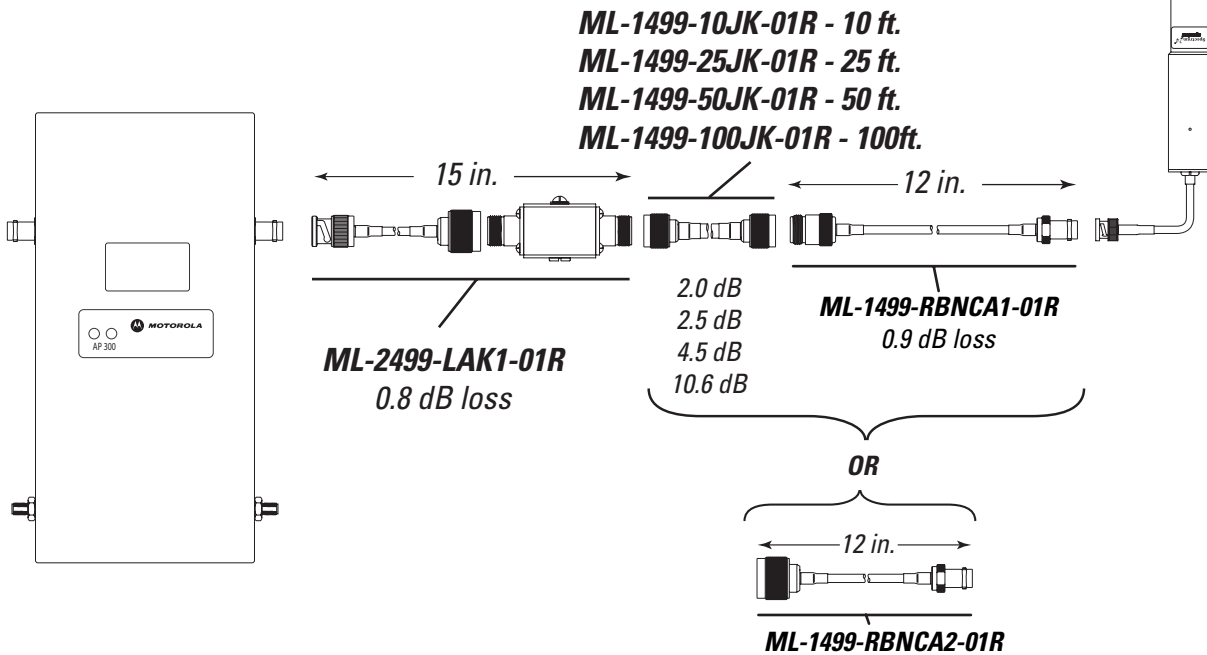

11.1.2 Type N Female Connector Installation

Refer to the following for a graphical depiction of the parts and connection options available for cabling an 2.4 GHz AP300 model access port using Type N female connectors.

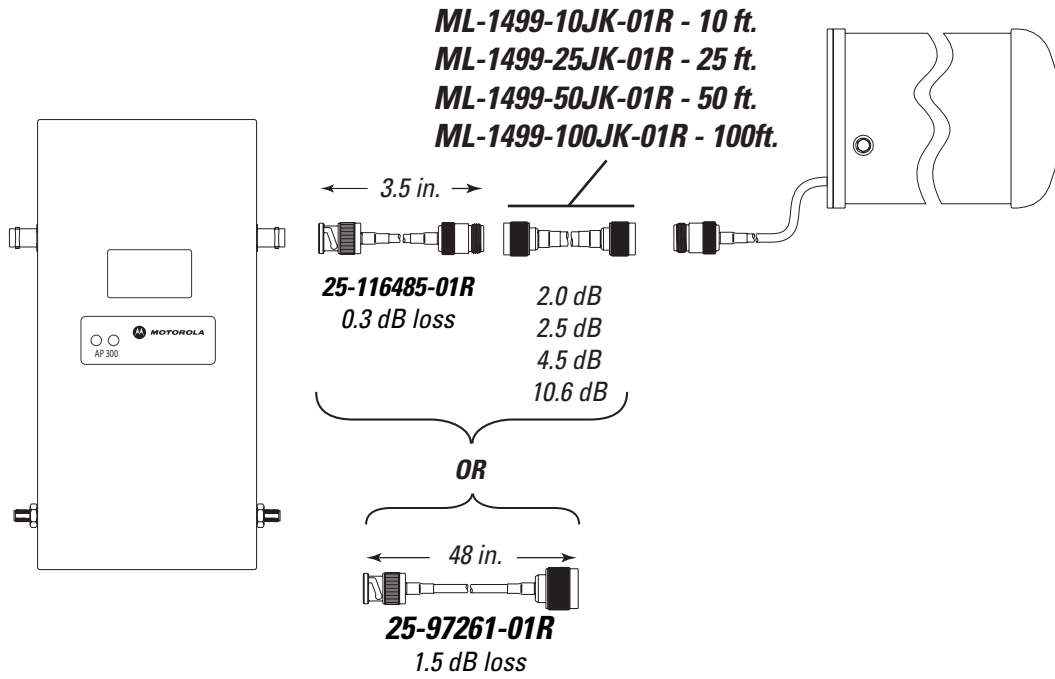

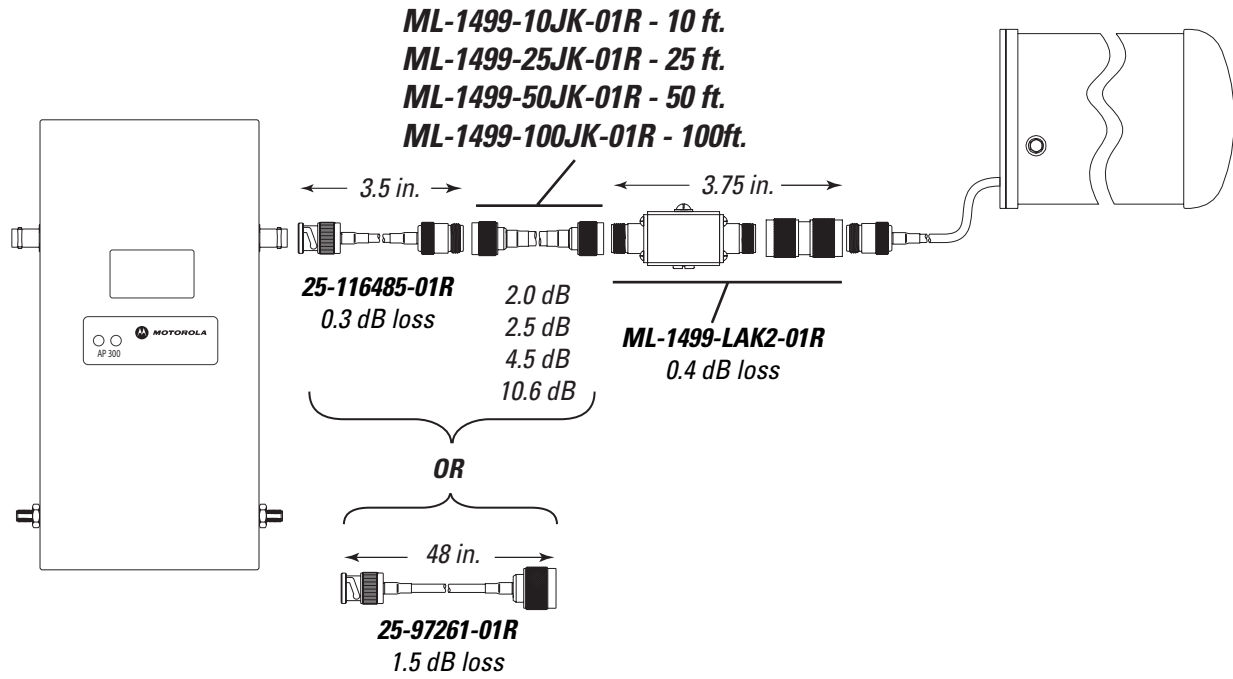

Lightning Aresstor, AP side

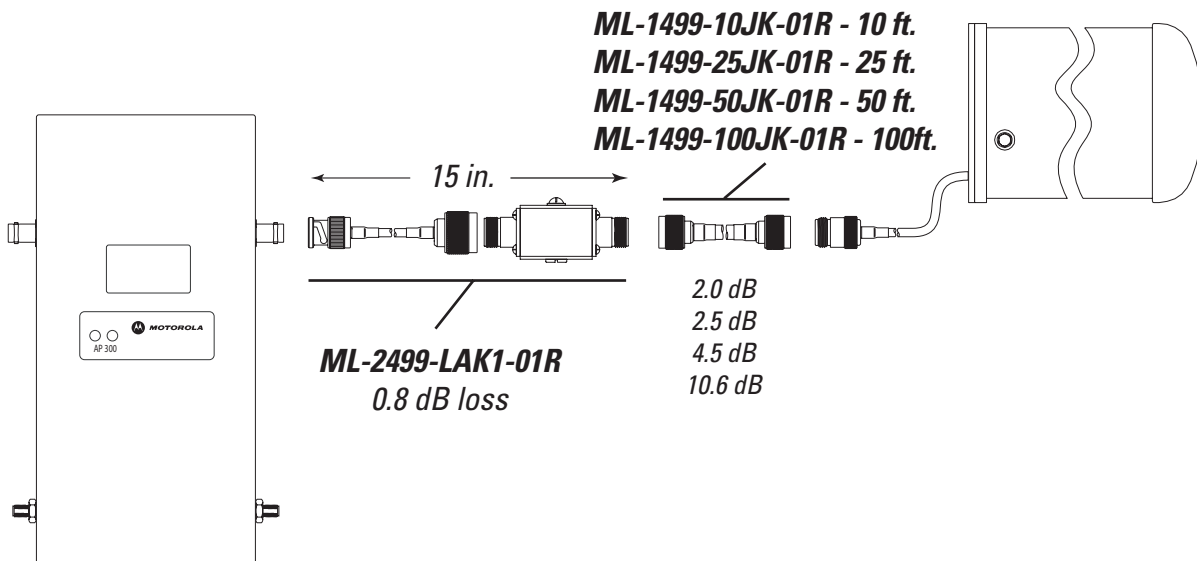

11.1.3 Type N Male Connector Installation

Refer to the following for a graphical depiction of the parts and connection options available for cabling an 2.4 GHz AP300 model access port using Type N male connectors:

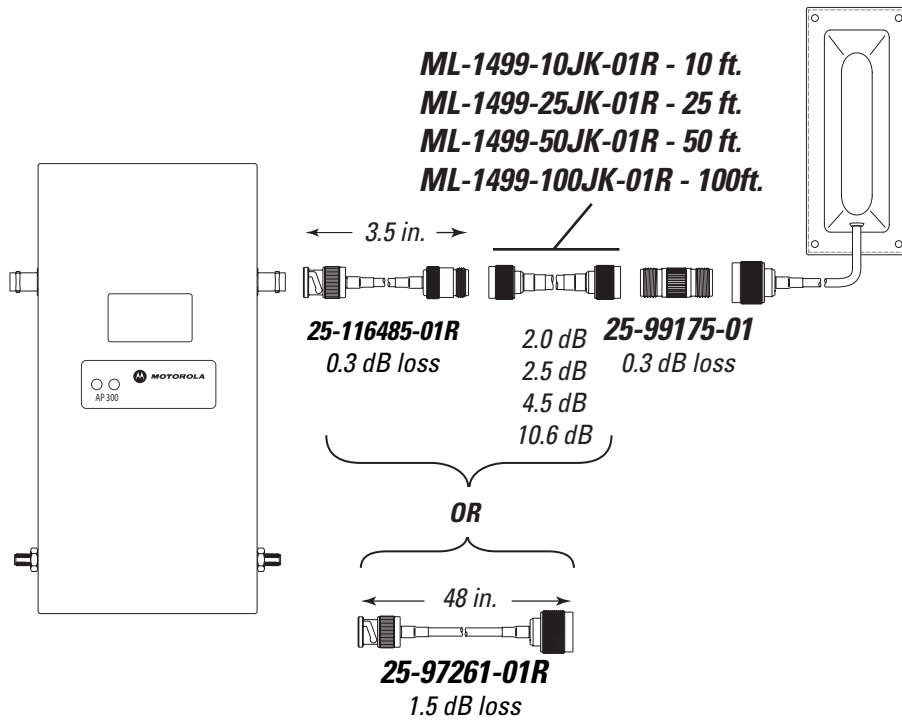

Lightning Arrestor, Antenna side

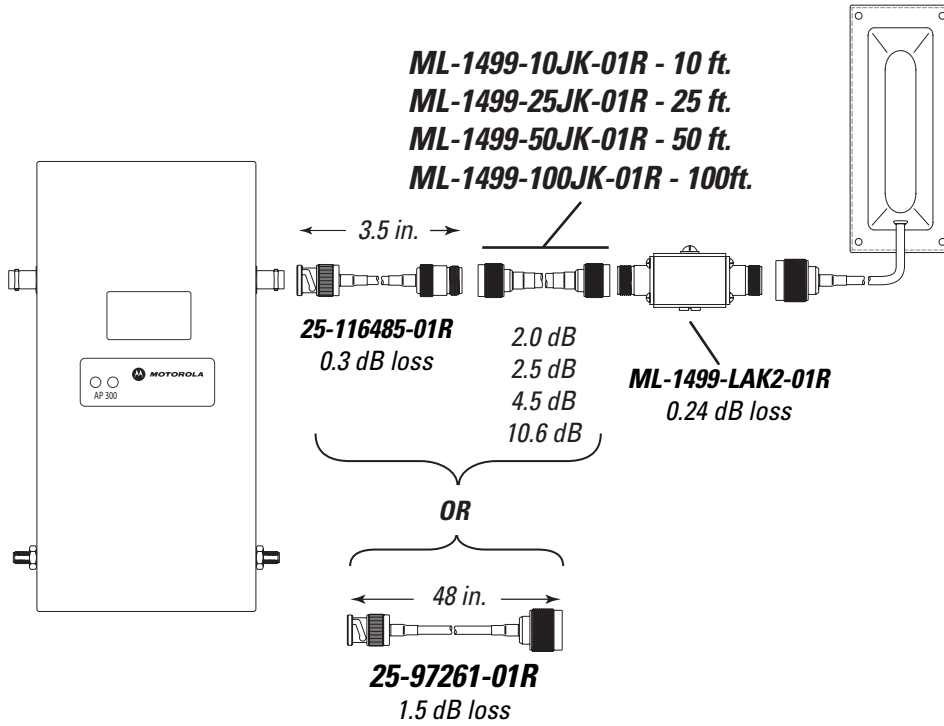

Lightning Arrestor, AP side

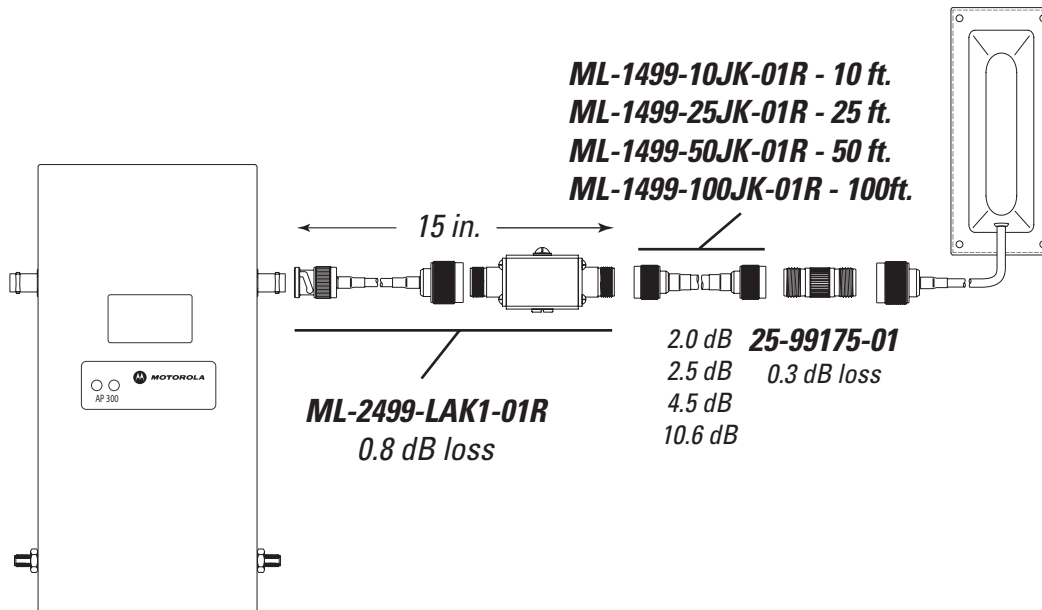

11.2 5 GHz AP300 Antenna Connections

This section describes how the components described within this guide are used collectively in the following AP300 installation scenarios supporting the 5 GHz band:

- [RP-SMA Male Antenna Installation](#)
- [Type N Male Connector Installation](#)

11.2.1 RP-SMA Male Antenna Installation

Refer to the following for a graphical depiction of the parts and connection options available for cabling an 5 GHz AP300 model access port using a RP-SMA male antenna.

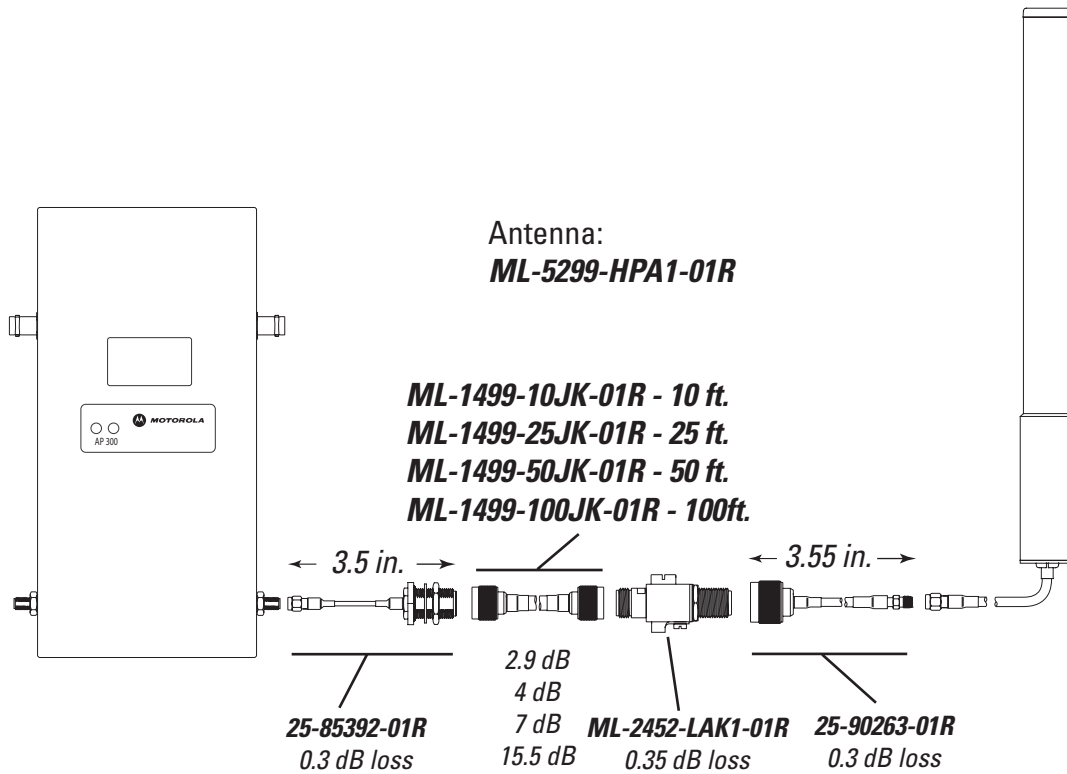

Lightning Aresstor, Antenna side

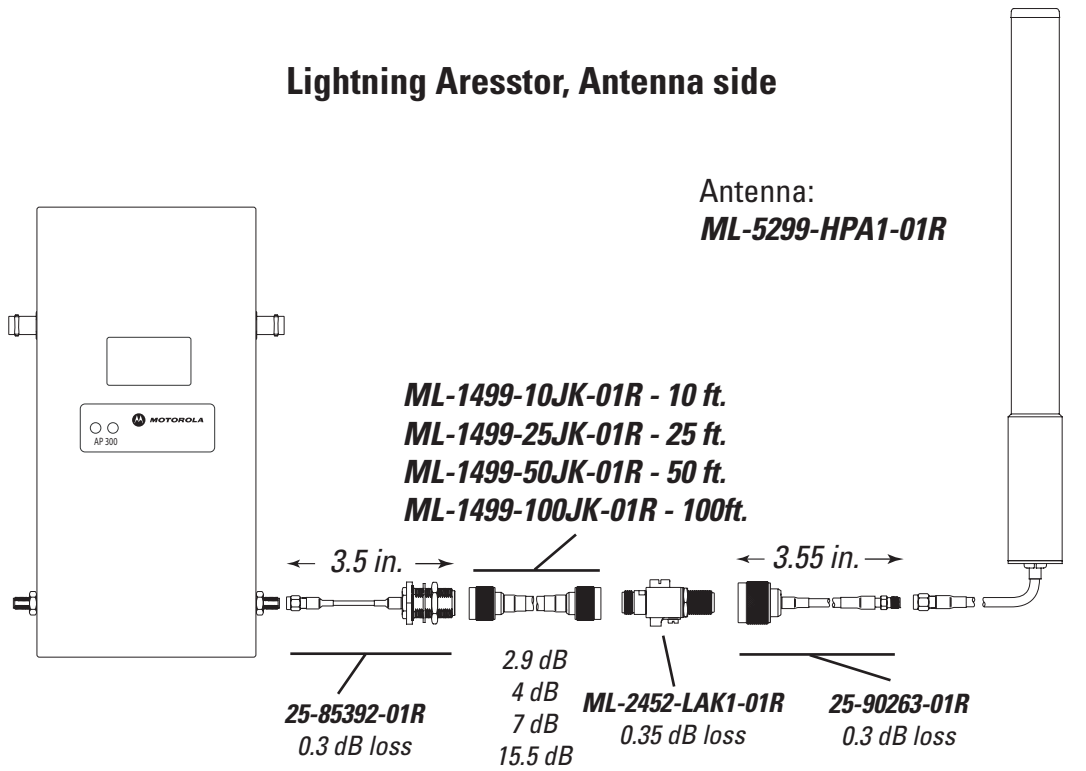

Lightning Aresstor, AP side

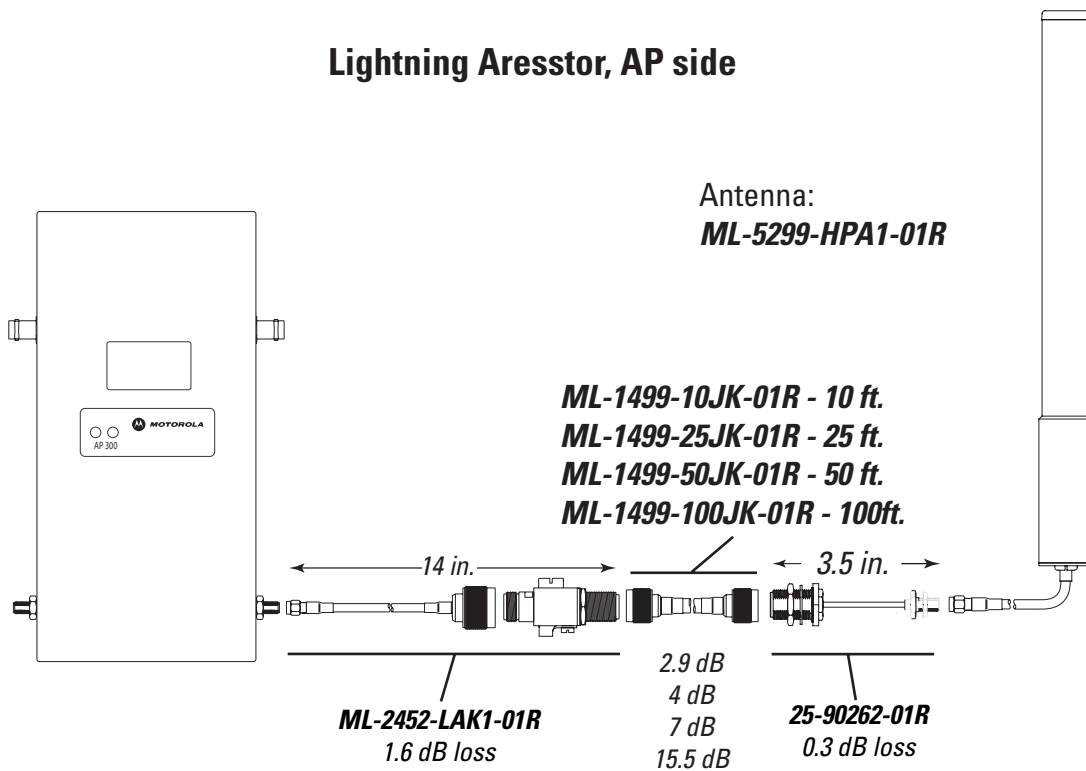

11.2.2 Type N Male Connector Installation

Refer to the following for a graphical depiction of the parts and connection options available for cabling an 5 GHz AP300 model access port using Type N male connectors:

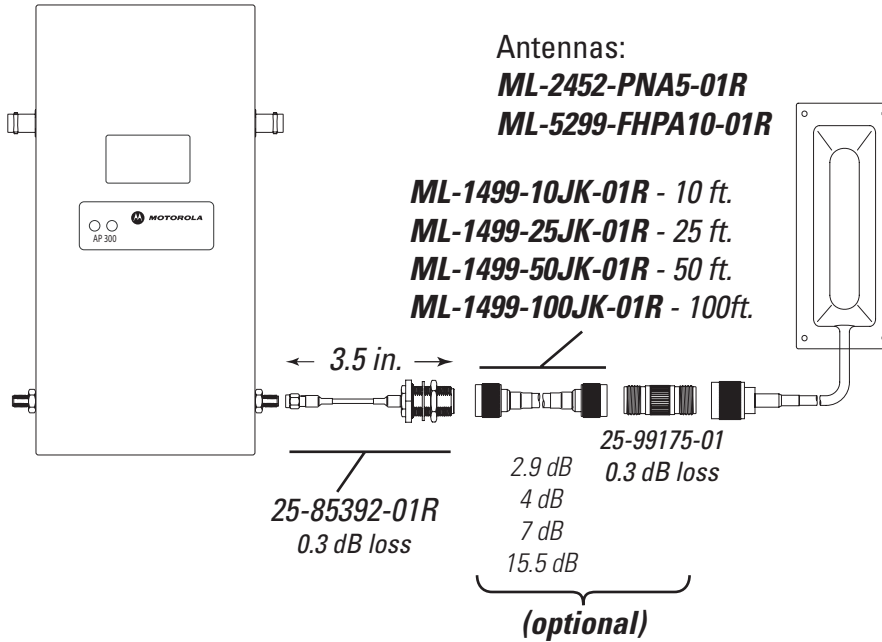

Lightning Aresstor, Antenna side

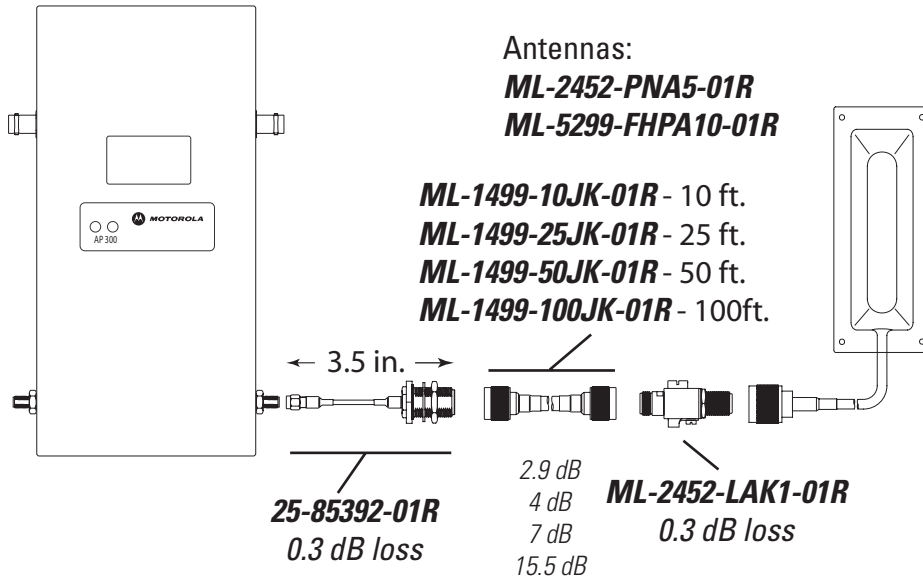

Lightning Aresstor, AP side

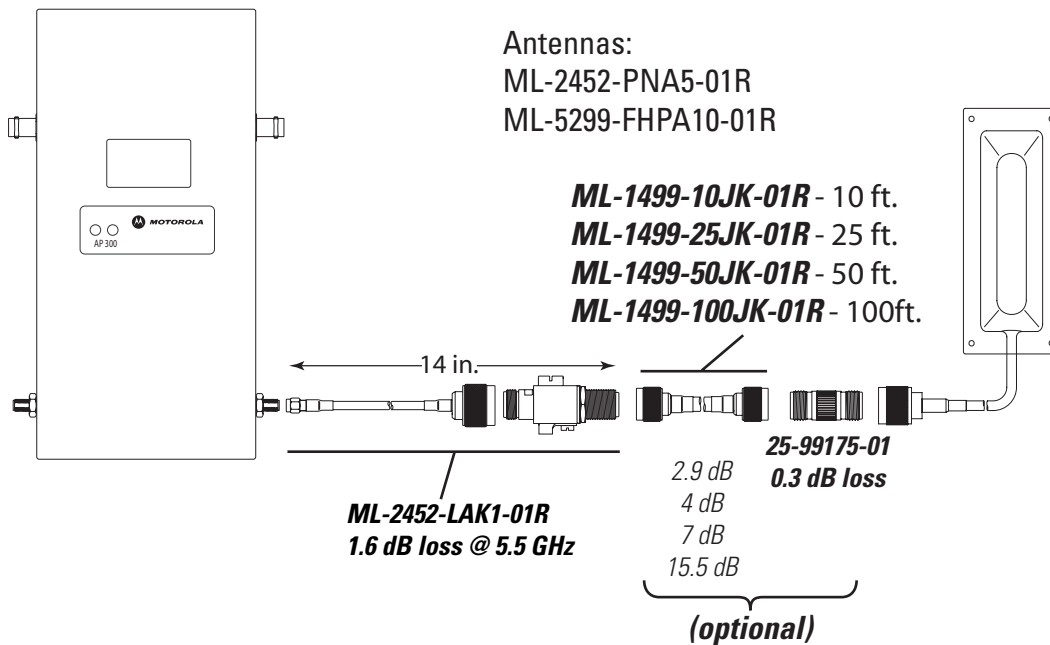

AP 7131 Transmit Power

12.1 Configuring the AP 7131 Series Transmit Power

Professional installers must configure an AP 7131 series access point so it does not violate FCC regulations pertaining to output transmit power.

This chapter describes how to adjust an AP 7131 series access point's radio transmit power.



NOTE: Motorola assumes the AP 7131 series access point radio and power configuration activities described in this chapter are conducted at the location that access point is actually installed and deployed.

To define an AP 7131 series access point's radio transmit power:

1. Complete the physical installation of the AP 7131 series access point following one of the supported mounting options within either the *AP 7131 Series Installation Guide* or *Product Reference Guide*. Both guides are available at <http://support.symbol.com/support/product/manuals.do>.

An AP 7131 series access point can attach to a wall, mount under a suspended T Bar or above a ceiling (plenum or attic) following the same installation instructions. Choose a mounting option based on the physical environment of the coverage area. Do not mount the access point in a location that has not been approved in a site survey.

2. Start a browser and enter the access point's default static IP address for the WAN port (10.1.1.1).
3. Initially log in using **admin** as the default Username and **motorola** as the default Password. Use your new password if it has been updated from default.

If the default login is successful, the **Change Admin Password** window displays. Change the password immediately to ensure secure access.

4. Select **System Configuration > Quick Setup** from the menu tree.

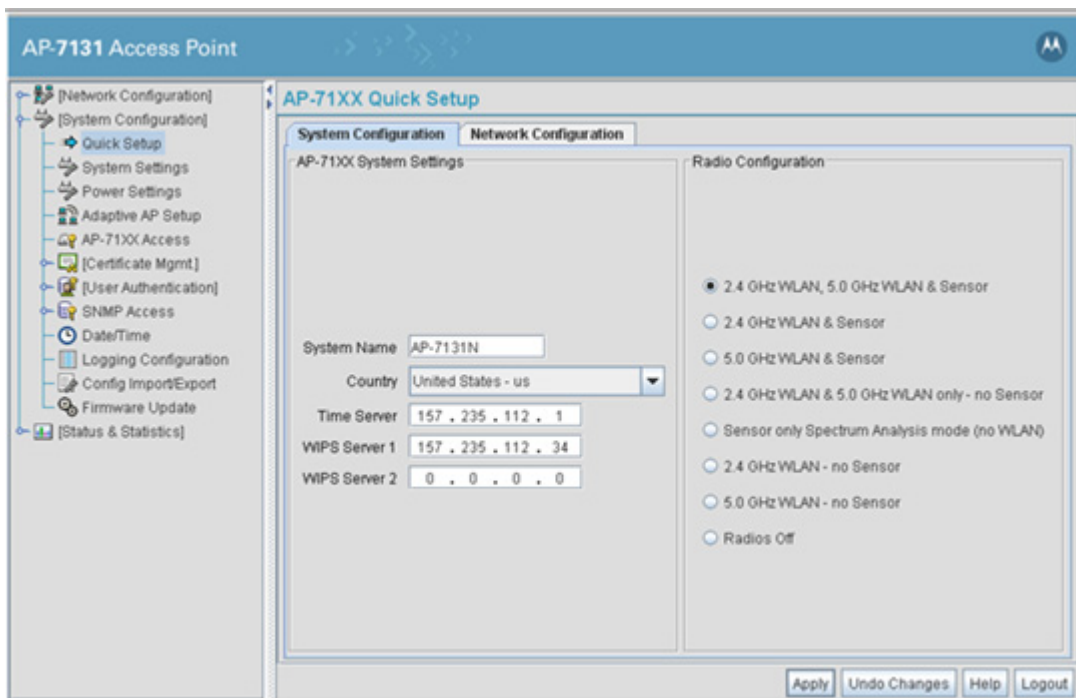

5. Select the **System Configuration** tab to define the access point's country code and radio configuration.
6. Select the **Country** for the access point's country of operation.

The access point prompts for the correct country code on the first login. A warning message also displays stating an incorrect country setting may result in illegal radio operation. Selecting the correct country is central to legally operating the access point. Each country has its own regulatory restrictions concerning electromagnetic emissions and the maximum RF signal strength that can be transmitted. To ensure compliance with national and local laws, set the country accurately.



NOTE: If the access point is a US supported model, the country code is automatically set to US.

7. Refer to the **Radio Configuration** field to define how WLAN and WIPS are supported by the access point's radio(s). Remember, the options available depend on the single, dual or three radio model deployed. Apply your settings when finished with the updates.

Radio Button	Single Radio SKU	Dual Radio SKU	Three Radio SKU
2.4 GHz WLAN, 5.0 GHz WLAN & Sensor	Not Available	Not Available	Radio 1 WLAN, Radio 2 WLAN, Radio 3 WIPS
2.4 GHz WLAN, & Sensor	Not Available	Radio1 WLAN, Radio 2 WIPS	Radio 1 WLAN, Radio 2 WIPS, Radio 3 WIPS
5.0 GHz WLAN & Sensor	Not Available	Radio 1 WIPS, Radio 2 WLAN	Radio 1 WIPS, Radio 2 WLAN, Radio 3 WIPS
2.4 GHz WLAN & 5.0 GHz WLAN only no Sensor	Not Available	Radio 1 WLAN, Radio 2 WLAN	Radio 1 WLAN, Radio 2 WLAN, Radio 3 Disabled
Sensor only Spectrum Analysis mode (no WLAN)	Radio 1 WIPS	Radio 1 WIPS, Radio 2 WIPS	Radio 1 WIPS, Radio 2 WIPS, Radio 3 Disabled
2.4 GHz WLAN no Sensor	Radio 1 WLAN (B/G/N)	Radio1 WLAN, Radio 2 Disabled	Radio 1 WLAN, Radio 2 Disabled, Radio 3 Disabled
5.0 GHz WLAN no Sensor	Radio 1 WLAN (A/N)	Radio1 Disabled, Radio 2 WLAN	Radio 1 Disabled, Radio 2 WLAN, Radio 3 Disabled
Radios Off	Radio 1 Disabled	Radios 1 and 2 Disabled	Radios 1, 2 and 3 Disabled

8. Select **System Configuration > Power Settings** from the menu tree.

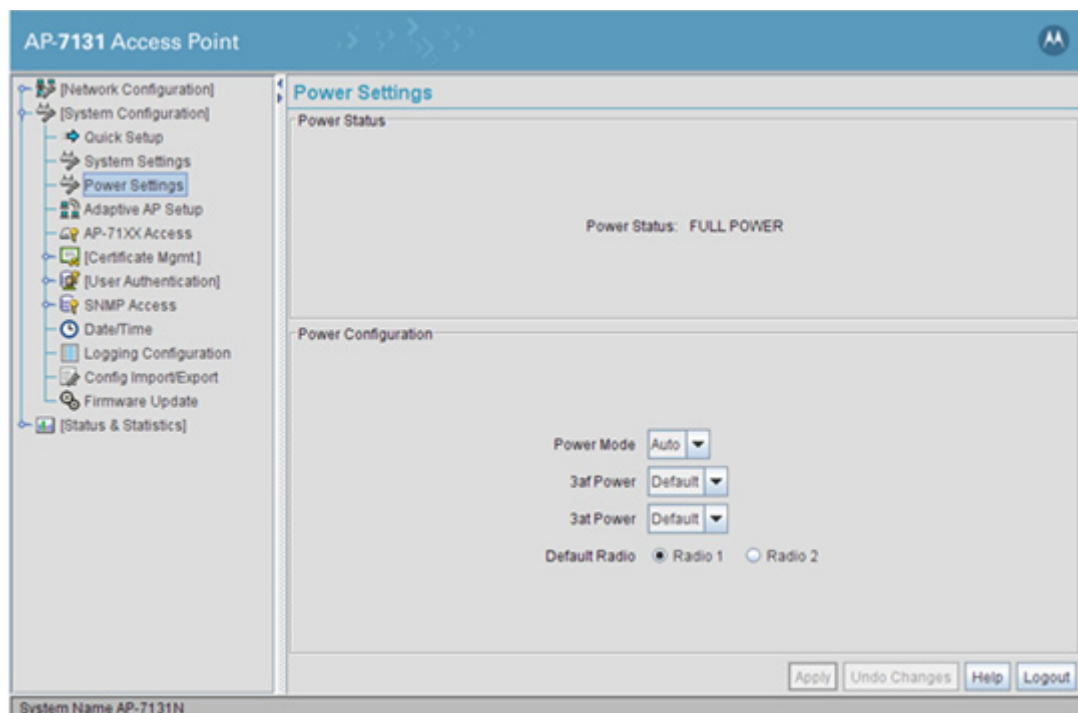

Within the **Power Configuration** field, an installation professional selects a power mode based on the different power resources available to that access point's SKU. For 3af and 3at, choose between **Default** and **Option** as best suited to that hardware SKU. For example, if Option is selected for 3af Power, and the access point is a dual radio model, the following configuration is set:

LAN port ON (1000 BASE T)

WAN port OFF

Radio 1 (2.4) on, 2x3 mode with maximum transmit power 18dBm

Radio 2 (5.0) on, 2x3 mode with maximum transmit power 18dBm

9. For this example, set the Power Mode to **Auto** (if not already defined as Auto by default). Leave the 3af and 3at Power settings as Default.

When the access point is powered on for the first time, the system determines the power budget available to the access point. Using the Auto setting (default setting), the access point automatically determines the best power configuration based on the available power budget. Therefore, the Auto power mode option affords the professional installer a smaller margin of error for legally setting the access point's transmit output power. If changes are made, reboot the access point.



NOTE: Ensure the access point is connected to its expected power supply (3af, 3at or Full Power). Check available access point power by reviewing the Power Status field within the Power Settings screen (this value is cable length dependent). Compare available power to the *Maximum Transmit Power vs POE* table below. If available supply power does not allow the desired transmit power, then increase the supply power.

Maximum Possible Transmit Power

Power Status	2.4 GHz	5.2 GHz
3af	+20	+19
3at	+23	+20
Full Power	+23	+20

10. Select **Network Configuration > Wireless > Radio Configuration > Radio1** or **Radio 2** from the access point menu tree.

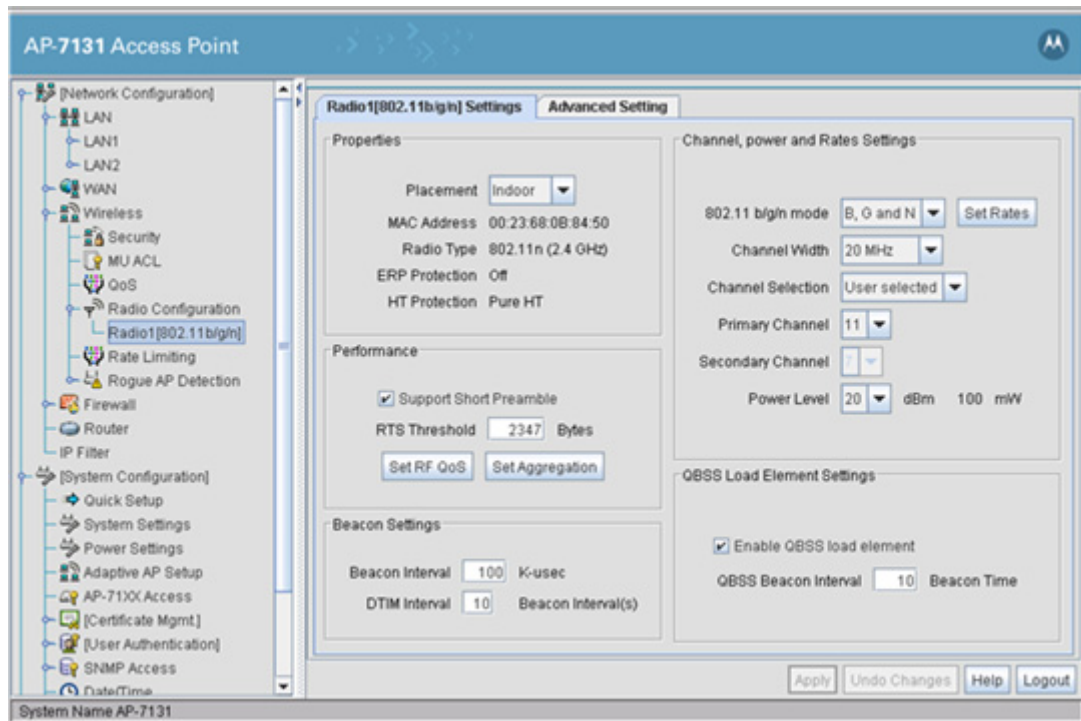

11. Refer to the **Channel, power and Rate Settings** field.

12. Set an 802.11 a/n or 802.11 b/g/n radio mode as appropriate.

For radio1, specify **B, G and N**, **B and G**, **G Only**, **B Only** or **N Only** to define whether the 802.11b/g/n radio transmits in the 2.4 GHz band exclusively for 802.11b (legacy) clients or transmits in the 2.4 GHz band for 802.11g/n clients. Selecting **B and G** enables the access point to transmit to both B and G clients if legacy clients (802.11b) partially comprise the network. Select accordingly based on the MU requirements of the network.



NOTE: Select the access point radio's 802.11 a/n or 802.11b/g/n mode carefully in respect to the radio's intended data rate and client support requirements, as the rates available differ depending on the selected mode. For more information on selected mode versus data rate, see [2.4 GHz Mode Versus Data Rate on page 12-8](#) or [5.2 GHz Mode Versus Data Rate on page 12-13](#).

The rates for the access point's 2.4 GHz radio are:

- *B, G and N* Allows only basic rates (default setting)
- *B and G* Allows 11b basic rates. Does not allow MCS rates
- *G and N* Requires basic rates (either 6, 12, 24 or 1, 2, 5.5, 11, 6, 12, 24)
- *G Only* Requires one 11g basic rate. Does not allow MCS rates
- *B Only* Allows for 11b rates only. Does not allow G or N rates
- *N Only* Requires basic MCS rates

If the mode is **B and G**, the Channel Width option is not available, and a Secondary Channel cannot be defined.

For the 5.2 GHz radio, specify **A and N**, **A Only** or **N Only** to define whether the 802.11a/n radio transmits in the 5.2 GHz band exclusively for 802.11a clients, 802.11n clients or transmits in the 5.2 GHz band for both 802.11a/n clients.

The rates for the access point's 5.2 GHz radio are:

- *A Only* Allows 11a rates
- *N Only* Requires basic MCS rates
- *A and N* Allows only 11a basic rates (default setting)

13. For this example, leave the Channel Width at **20/40** and set the Channel to **User selected** for both the 802.11 b/g/n and 802.11 a/n radios.

20/40 MHz operation (the default setting for the 5 GHz radio) allows the access point to receive packets from clients using 20 MHz of bandwidth while transmitting a packet using 40 MHz bandwidth. This mode is supported for 11n users on both the 2.4 and 5 GHz radios. If an 11n user selects two channels (a Primary and Secondary channel), the system is configured for dynamic 20/40 operation. When 20/40 is selected, clients can take advantage of "wider channels." 802.11n clients experience improved throughput using 40 MHz while legacy clients (either 802.11a or 802.11b/g depending on the radio selected) can still be serviced without interruption using 20 MHz.

User selected is the default Channel Selection setting. If 20/40 MHz is selected as the Channel Width (supporting 11n), the Secondary Channel drop down menu becomes enabled. The user must define the primary channel first. Then, depending on the primary channel defined, the secondary channel list is filled with channels making the combination of primary and secondary channels valid. The actual channels available depend on regulatory domain requirements.

14. Set the **Power Level** in respect to the antennas deployed and the defined channel.



NOTE: If you set the transmit power too high (in relation to FCC transmit requirements), the access point will display an Input Error message stating the maximum power level for the selected channel has been exceeded.

15. Select **Status and Statistics > Radio Stats > Radio1(802.11b/g/n) Statistics or Radio2 (802.11a/n) Statistics** from the access point menu tree.

Refer to the **Current Channel** parameter from within the Information field. This value displays (in red) the two channels utilized as a result of selecting 20/40 as the Channel Width. The first value represents the channel utilized for the 20 MHz bandwidth and the second value (displayed in parenthesis) is the channel supporting 40 MHz.

12.1.1 Supported Antennas by Band, Model, Rate and Transmit Power

Refer to the following Motorola AP 7131 supported antennas for their US Regulatory Domain transmit power (in both the 2.4 and 5.2 GHz bands), rates and supported channels.

US Regulatory Domain 2.4 GHz Band

- *Yagi Antenna Models*
 - *Yagi Antenna Maximum Conducted Transmit Power Settings*
- *Panel Antenna Models*
 - *Panel Antenna Maximum Conducted Transmit Power Settings*
- *Embedded Antenna Models*
 - *Embedded Antenna Maximum Conducted Transmit Power Settings*
- *Dipole Antenna Models*
 - *Dipole Antenna Maximum Conducted Transmit Power Settings*
- *Patch Antenna Models*
 - *Patch Antenna Maximum Conducted Transmit Power Settings*

US Regulatory Domain 5.2 GHz Band

- *Yagi Antenna Models*
 - *Yagi Antenna Maximum Conducted Transmit Power Settings*
- *Panel Antenna Models*
 - *Panel Antenna Maximum Conducted Transmit Power Settings*
- *Embedded Antenna Models*
 - *Embedded Antenna Maximum Conducted Transmit Power Settings*
- *Dipole Antenna Models*
 - *Dipole Antenna Maximum Conducted Transmit Power Settings*
- *Patch Antenna Models*
 - *Patch Antenna Maximum Conducted Transmit Power Settings*

12.2 US Regulatory Domain 2.4 GHz Band

12.2.1 2.4 GHz Mode Versus Data Rate

When setting 2.4 GHz data rates using the access point's GUI applet, use the following chart to cross reference data rates to the radio's selected operational mode.

	<i>B, G and N</i>	<i>G and N</i>	<i>N Only</i>	<i>B and G</i>	<i>G Only</i>	<i>B Only</i>
LEGACY DSSS RATES (1, 2, 5.5, 11 MBPS)	X			X		X
LEGACY OFDM RATES (6,9,12,18,24,36,48,54 MBPS)	X	X		X	X	
802.11n HT20 RATES (MCS 0 MCS 15)	X	X	X			
802.11n HT40 RATES (MCS 0 MCS15)	X	X	X			

12.2.2 Yagi Antenna Models

The following is the Yagi antenna model for 2.4 GHz:

Motorola Part Number
ML-2499-BYGA2-01R

12.2.2.1 Yagi Antenna Maximum Conducted Transmit Power Settings

The following is a transmit power table (US domain) per Yagi antenna in the 2.4 GHz band:

20 MHZ CHANNEL	40 MHZ CHANNEL	LEGACY DSSS RATES (1, 2, 5.5, 11 MBPS)	LEGACY OFDM RATES (6,9,12,18,24,36, 48,54 MBPS)	802.11n HT20 RATES (MCS 0 MCS 15)	802.11n HT40 RATES (MCS 0 MCS15)
1		13	7	7	
2		13	7	7	
3	(1, 5)	13	7	7	2
4	(2, 6)	13	7	7	2
5	(3, 7)	13	7	7	2
6	(4, 8)	13	8	8	5
7	(5, 9)	12	7	6	2
8	(6, 10)	12	7	6	2
9	(7, 11)	12	7	6	2
10		12	7	6	
11		12	7	6	

With the most recent AP 7131 series software release (4.0.0.0) the Web browser of the command line interface do not allow setting the transmit power to any value less than 4dBm.



NOTE: When a Yagi antenna is used, a 2dB external RF attenuator must be added. Lower power settings will be provided in subsequent software releases.

12.2.3 Panel Antenna Models

The following is the panel antenna model for 2.4 GHz:

<i>Motorola Part Number</i>
ML-2452-PTA3M3-036

12.2.3.1 Panel Antenna Maximum Conducted Transmit Power Settings

The following is a transmit power table (US domain) per panel antenna in the 2.4 GHz band:

20 MHZ CHANNEL	40 MHZ CHANNEL	LEGACY DSSS RATES (1, 2, 5.5, 11 MBPS)	LEGACY OFDM RATES (6,9,12,18,24,36, 48,54 MBPS)	802.11n HT20 RATES (MCS 0 MCS 15)	802.11n HT40 RATES (MCS 0 MCS15)
1		16	11	10	
2		16	11	10	
3	(1, 5)	16	11	10	7
4	(2, 6)	16	11	10	7
5	(3, 7)	16	11	10	7
6	(4, 8)	16	11	11	8
7	(5, 9)	16	11	9	5
8	(6, 10)	16	11	9	5
9	(7, 11)	16	11	9	5
10		16	11	9	
11		16	11	9	

12.2.4 Embedded Antenna Models

The following is the embedded antenna model for 2.4 GHz:

Motorola Part Number
ML-2452-PTA2M3X3-1

12.2.4.1 Embedded Antenna Maximum Conducted Transmit Power Settings

The following is a transmit power table (US domain) per embedded antenna in the 2.4 GHz band:

20 MHZ CHANNEL	40 MHZ CHANNEL	LEGACY DSSS RATES (1, 2, 5.5, 11 MBPS)	LEGACY OFDM RATES (6,9,12,18,24,36, 48,54 MBPS)	802.11n HT20 RATES (MCS 0 MCS 15)	802.11n HT40 RATES (MCS 0 MCS15)
1		20	16	16	
2		20	16	16	
3	(1, 5)	20	16	16	11
4	(2, 6)	20	16	16	11
5	(3, 7)	20	16	16	11
6	(4, 8)	18	14	14	12
7	(5, 9)	16	15	15	12
8	(6, 10)	16	15	15	12
9	(7, 11)	16	15	15	12
10		16	15	15	
11		16	15	15	

12.2.5 Dipole Antenna Models

The following are the dipole antenna models for 2.4 GHz:

Motorola Part Number	2.4 GHz Antenna Net Gain
ML-2452-APA2-01	3
ML-2499-HPA3-01R	3.3
ML-2452-APA6J-01 (microcell)	6

12.2.5.1 Dipole Antenna Maximum Conducted Transmit Power Settings

The following is a transmit power table (US domain) per dipole antenna in the 2.4 GHz band:



NOTE: The access point GUI only allows whole numbers be entered for transmit power. The decimal values are displayed within these tables to help installers accommodate for cable and accessory losses.

20 MHZ CHANNEL	40 MHZ CHANNEL	LEGACY DSSS RATES (1, 2, 5.5, 11 MBPS)	LEGACY OFDM RATES (6,9,12,18,24,36, 48,54 MBPS)	802.11n HT20 RATES (MCS 0 MCS 15)	802.11n HT40 RATES (MCS0 MCS15)
1		18.5	15.0	15.0	
2		18.5	15.0	15.0	
3	(1, 5)	18.5	16.0	16.5	10.0
4	(2, 6)	18.5	16.0	16.5	11.0
5	(3, 7)	18.5	16.0	16.0	12.0
6	(4, 8)	23.0	16.0	16.5	13.0
7	(5, 9)	19.0	16.0	16.5	12.0
8	(6, 10)	19.0	16.0	16.5	11.0
9	(7, 11)	19.0	15.0	16.5	9.0
10		19.0	14.0	16.0	
11		19.0	13.5	13.0	

12.2.6 Patch Antenna Models

The following is the patch antenna model for 2.4 GHz:

Motorola Part Number	2.4 GHz Antenna Net Gain
ML-2452-PTA3M3-036	3

12.2.6.1 Patch Antenna Maximum Conducted Transmit Power Settings

The following is a transmit power table (US domain) per patch antenna in the 2.4 GHz band:

20 MHZ CHANNEL	40 MHZ CHANNEL	LEGACY DSSS RATES (1, 2, 5.5, 11 MBPS)	LEGACY OFDM RATES (6,9,12,18,24,36, 48,54 MBPS)	802.11n HT20 RATES (MCS 0 MCS 15)	802.11n HT40 RATES (MCS0 MCS15)
1		16	15	12	
2		16	15	12	
3	(1, 5)	16	15	12	9
4	(2, 6)	16	15	12	9
5	(3, 7)	16	15	12	9
6	(4, 8)	20	15	15	12
7	(5, 9)	18	13	12	10
8	(6, 10)	18	13	12	10
9	(7, 11)	18	13	12	10
10		18	13	12	
11		18	13	12	

12.3 US Regulatory Domain 5.2 GHz Band

12.3.1 5.2 GHz Mode Versus Data Rate

When setting 5.2 GHz data rates using the access point's GUI applet, use the following chart to cross reference data rates to the radio's selected operational mode.

	<i>A and N</i>	<i>N Only</i>	<i>A Only</i>
LEGACY OFDM RATES (6,9,12,18,24,36,48,54 MBPS)	X		X
802.11n HT20 RATES (MCS 0 MCS 15)	X	X	
802.11n HT40 RATES (MCS 0 MCS 15)	X	X	

12.3.2 Yagi Antenna Models

The following is the Yagi antenna model for 5.2 GHz:

Motorola Part Number
ML-5299-BYGA15-012

12.3.2.1 Yagi Antenna Maximum Conducted Transmit Power Settings

The following is a transmit power table (US domain) per Yagi antenna in the 5 GHz band:

20 MHZ CHANNEL	40 MHZ CHANNEL	LEGACY OFDM RATES (6,9,12,18,24,36,48,54 MBPS)	802.11n HT20 RATES (MCS 0 MCS 15)	802.11n HT40 RATES (MCS 0 MCS 15)
36		2	2.5	
38	(36, 40)			4
40		2	2.5	
42		2.5	2.5	
44		2.5	2.5	
46	(44, 48)			4
48		2.5	4	
52		9	9	
54	(52, 56)			11
56		9	9	
60		8.5	9	
62	(60, 64)			10
64		8.5	9	
100		8	8.5	

20 MHZ CHANNEL	40 MHZ CHANNEL	LEGACY OFDM RATES (6,9,12,18,24,36,48,54 MBPS)	802.11n HT20 RATES (MCS 0 MCS 15)	802.11n HT40 RATES (MCS 0 MCS 15)
102	(100, 104)			5
104		8	8.5	
108		8	8.5	
112		8	8.5	
110	(108, 112)			11
116		8	8.5	
118	(116, 120)			10
120		8	8.5	
124		7.5	7.5	
126	(124, 128)			10
128		7.5	7.5	
132		7.5	7.5	
134	(132, 136)			10
136		7.5	7.5	
140		7.5	7.5	
149		7.0	7.5	
151	(149, 153)			4.5
153		7.0	7.5	
157		7.5	8.0	
159	(157, 161)			5.0
161		8.0	9.0	
165		8.0	9.0	

12.3.3 Panel Antenna Models

The following are the panel antenna models for 5.2 GHz:

Motorola Part Number
ML-5299-WPNA1-01R
ML-2452-PNL9M3-036

12.3.3.1 Panel Antenna Maximum Conducted Transmit Power Settings

The following is a transmit power table (US domain) per panel antenna in the 5 GHz band:

20 MHZ CHANNEL	40 MHZ CHANNEL	LEGACY OFDM RATES (6,9,12,18,24,36,48,54 MBPS)	802.11n HT20 RATES (MCS 0 MCS 15)	802.11n HT40 RATES (MCS 0 MCS 15)
36		4	4	
38	(36, 40)			6
40		4	4	
42		4	4	
44		4	4	
46	(44, 48)			6
48		4	4	
52		10	10	
54	(52, 56)			13
56		10	10	
60		10	10	
62	(60, 64)			11
64		10	10	
100		10	10	
102	(100, 104)			5
104		10	10	
108		10	10	
112		10	10	
110	(108, 112)			13
116		10	10	
118	(116, 120)			13
120		10	10	
124		10	10	
126	(124, 128)			12

20 MHZ CHANNEL	40 MHZ CHANNEL	LEGACY OFDM RATES (6,9,12,18,24,36,48,54 MBPS)	802.11n HT20 RATES (MCS 0 MCS 15)	802.11n HT40 RATES (MCS 0 MCS 15)
128		10	10	
132		10	10	
134	(132, 136)			12
136		10	10	
140		8	8	
149		8.0	9.0	
151	(149, 153)			6.0
153		8.0	9.0	
157		9.0	10.0	
159	(157, 161)			7.0
161		10	10	
165		10	10	

12.3.4 Embedded Antenna Models

The following is the embedded antenna model for 5.2 GHz:

Motorola Part Number
ML-2452-PTA2M3X3-1

12.3.4.1 Embedded Antenna Maximum Conducted Transmit Power Settings

The following is a transmit power table (US domain) per embedded antenna in the 5 GHz band:

20 MHZ CHANNEL	40 MHZ CHANNEL	LEGACY OFDM RATES (6,9,12,18,24,36,48,54 MBPS)	802.11n HT20 RATES (MCS 0 MCS 15)	802.11n HT40 RATES (MCS 0 MCS 15)
36		11	11	
38	(36, 40)			12
40		11	11	
42		11	11	
44		11	11	
46	(44, 48)			13
48		11	11	
52		18	18	
54	(52, 56)			20
56		18	18	
60		18	18	
62	(60, 64)			14
64		18	18	
100		15	16	
102	(100, 104)			8
104		14	16	
108		14	16	
112		14	16	
110	(108, 112)			19
116		14	16	
118	(116, 120)			19
120		18	18	
124		18	13	
126	(124, 128)			19
128		14	13	

20 MHZ CHANNEL	40 MHZ CHANNEL	LEGACY OFDM RATES (6,9,12,18,24,36,48,54 MBPS)	802.11n HT20 RATES (MCS 0 MCS 15)	802.11n HT40 RATES (MCS 0 MCS 15)
132		14	13	
134	(132, 136)			14
136		13	13	
140		13	13	
149		18.0	18.0	
151	(149, 153)			15.0
153		18.0	18.0	
157		18.0	18.0	
159	(157, 161)			16.0
161		19.0	19.0	
165		19.0	19.0	

12.3.5 Dipole Antenna Models

The following are the dipole antenna models for 5.2 GHz:

Motorola Part Number
ML-5299HPA1-01R
ML-2452-APA6J-01
ML-2452-APA2-01

12.3.5.1 Dipole Antenna Maximum Conducted Transmit Power Settings

The following is a transmit power table (US domain) per dipole antenna in the 5 GHz band:

20 MHZ CHANNEL	40 MHZ CHANNEL	LEGACY OFDM RATES (6,9,12,18,24,36,48,54 MBPS)	802.11n HT20 RATES (MCS 0 MCS 15)	802.11n HT40 RATES (MCS 0 MCS 15)
36		11	11	
38	(36, 40)			12
40		11	11	
42		11	11	
44		11	11	
46	(44, 48)			13
48		11	11	
52		18	18	
54	(52, 56)			20
56		18	18	
60		18	18	
62	(60, 64)			14
64		18	18	
100		15	14	
102	(100, 104)			7
104		15	14	
108		15	14	
112		15	14	
110	(108, 112)			19
116		15	14	
118	(116, 120)			19
120		18	18	
124		15	18	

20 MHZ CHANNEL	40 MHZ CHANNEL	LEGACY OFDM RATES (6,9,12,18,24,36,48,54 MBPS)	802.11n HT20 RATES (MCS 0 MCS 15)	802.11n HT40 RATES (MCS 0 MCS 15)
126	(124, 128)			19
128		15	18	
132		15	18	
134	(132, 136)			14
136		13	16	
140		13	16	
149		18.0	18.0	
151	(149, 153)			15.0
153		18.0	19.0	
157		18.0	19.0	
159	(157, 161)			16.0
161		19.0	19.0	
165		19.0	19.0	

12.3.6 Patch Antenna Models

The following is the patch antenna model for 5.2 GHz:

Motorola Part Number
ML-2452-PTA3M3-036

12.3.6.1 Patch Antenna Maximum Conducted Transmit Power Settings

The following is a transmit power table (US domain) per patch antenna in the 5 GHz band:

20 MHZ CHANNEL	40 MHZ CHANNEL	LEGACY OFDM RATES (6,9,12,18,24,36,48,54 MBPS)	802.11n HT20 RATES (MCS 0 MCS 15)	802.11n HT40 RATES (MCS 0 MCS 15)
36		11	11	
38	(36, 40)			12
40		11	11	
42		11	11	
44		11	11	
46	(44, 48)			13
48		11	11	
52		18	18	
54	(52, 56)			20
56		18	18	
60		18	18	
62	(60, 64)			14
64		18	18	
100		15	16	
102	(100, 104)			8
104		18	16	
108		18	16	
112		18	18	
110	(108, 112)			13
116		18	18	
118	(116, 120)			19
120		18	18	
124		18	18	
126	(124, 128)			19
128		18	18	

20 MHZ CHANNEL	40 MHZ CHANNEL	LEGACY OFDM RATES (6,9,12,18,24,36,48,54 MBPS)	802.11n HT20 RATES (MCS 0 MCS 15)	802.11n HT40 RATES (MCS 0 MCS 15)
132		18	18	
134	(132, 136)			14
136		13	13	
140		13	13	
149		18.0	18.0	
151	(149, 153)			15.0
153		18.0	19.0	
157		18.0	19.0	
159	(157, 161)			16.0
161		19.0	19.0	
165		19.0	19.0	

12.4 Japanese TELEC Regulatory Domain 2.4 GHz Band

12.4.1 Panel Antenna Model

The following is the panel antenna model for 2.4 GHz:

Motorola Part Number
ML-2499-11PNA2-01R

12.4.1.1 Panel Antenna Maximum Conducted Transmit Power Settings

The following is a transmit power table (Japanese domain) per panel antenna in the 2.4 GHz band:

20 MHZ CHANNEL	40 MHZ CHANNEL	LEGACY DSSS RATES (1, 2, 5.5, 11 MBPS)	LEGACY OFDM RATES (6,9,12,18,24,36, 48,54 MBPS)	802.11n HT20 RATES (MCS 0 MCS 15)	802.11n HT40 RATES (MCS 0 MCS15)
1		19.0	19.0	19.0	
2		19.0	19.0	19.0	
3	(1, 5)	19.0	19.0	19.0	16.0
4	(2, 6)	19.0	19.0	19.0	16.0
5	(3, 7)	19.0	19.0	19.0	16.0
6	(4, 8)	19.0	19.0	19.0	16.0
7	(5, 9)	19.0	19.0	19.0	16.0
8	(6, 10)	19.0	19.0	19.0	16.0
9	(7, 11)	19.0	19.0	19.0	16.0
10		19.0	19.0	19.0	
11		19.0	19.0	19.0	
12		19.0	19.0	19.0	
13		19.0	19.0	19.0	
14		19.0			

12.4.2 Embedded Antenna Model

The following is the embedded antenna model for 2.4 GHz:

Motorola Part Number
ML-2452-PTA2M3X3-1

12.4.2.1 Panel Antenna Maximum Conducted Transmit Power Settings

The following is a transmit power table (Japanese domain) per embedded antenna in the 2.4 GHz band:

20 MHZ CHANNEL	40 MHZ CHANNEL	LEGACY DSSS RATES (1, 2, 5.5, 11 MBPS)	LEGACY OFDM RATES (6,9,12,18,24,36, 48,54 MBPS)	802.11n HT20 RATES (MCS 0 MCS 15)	802.11n HT40 RATES (MCS 0 MCS15)
1		11.0	11.0	11.0	
2		11.0	11.0	11.0	
3	(1, 5)	11.0	11.0	11.0	8.0
4	(2, 6)	11.0	11.0	11.0	8.0
5	(3, 7)	11.0	11.0	11.0	8.0
6	(4, 8)	11.0	11.0	11.0	8.0
7	(5, 9)	11.0	11.0	11.0	8.0
8	(6, 10)	11.0	11.0	11.0	8.0
9	(7, 11)	11.0	11.0	11.0	8.0
10		11.0	11.0	11.0	
11		11.0	11.0	11.0	
12		11.0	11.0	11.0	
13		11.0	11.0	11.0	
14		11.0			

12.4.3 Dipole Antenna Model

The following is the patch antenna model for 2.4 GHz:

Motorola Part Number
ML-2452-APA2-01
ML-2499-HPA3-01R
ML-2452-APA6J-01 (microcell)

12.4.3.1 Dipole Antenna Maximum Conducted Transmit Power Settings

The following is a transmit power table (Japanese domain) per dipole antenna in the 2.4 GHz band:

20 MHZ CHANNEL	40 MHZ CHANNEL	LEGACY DSSS RATES (1, 2, 5.5, 11 MBPS)	LEGACY OFDM RATES (6,9,12,18,24,36, 48,54 MBPS)	802.11n HT20 RATES (MCS 0 MCS 15)	802.11n HT40 RATES (MCS 0 MCS15)
1		14.0	14.0	14.0	
2		14.0	14.0	14.0	
3	(1, 5)	14.0	14.0	14.0	11
4	(2, 6)	14.0	14.0	14.0	11
5	(3, 7)	14.0	14.0	14.0	11
6	(4, 8)	14.0	14.0	14.0	11
7	(5, 9)	14.0	14.0	14.0	11
8	(6, 10)	14.0	14.0	14.0	11
9	(7, 11)	14.0	14.0	14.0	11
10		14.0	14.0	14.0	
11		14.0	14.0	14.0	
12		14.0	14.0	14.0	
13		14.0	14.0	14.0	
14		14.0			

12.4.4 Patch Antenna Model

The following is the patch antenna model for 2.4 GHz:

Motorola Part Number	2.4 GHz Antenna Net Gain
ML-2452-PTA3M3-036	3

12.4.4.1 Patch Antenna Maximum Conducted Transmit Power Settings

The following is a transmit power table (Japanese domain) per patch antenna in the 2.4 GHz band:

20 MHZ CHANNEL	40 MHZ CHANNEL	LEGACY DSSS RATES (1, 2, 5.5, 11 MBPS)	LEGACY OFDM RATES (6,9,12,18,24,36, 48,54 MBPS)	802.11n HT20 RATES (MCS 0 MCS 15)	802.11n HT40 RATES (MCS0 MCS15)
1		16.0	16.0	16.0	
2		16.0	16.0	16.0	
3	(1, 5)	16.0	16.0	16.0	10.0
4	(2, 6)	16.0	16.0	16.0	10.0
5	(3, 7)	16.0	16.0	16.0	10.0
6	(4, 8)	16.0	16.0	16.0	10.0
7	(5, 9)	16.0	16.0	16.0	10.0
8	(6, 10)	16.0	16.0	16.0	10.0
9	(7, 11)	16.0	16.0	16.0	10.0
10		16.0	16.0	16.0	
11		16.0	16.0	16.0	
12		16.0	16.0	16.0	
13		16.0	16.0	16.0	
14		16.0			

12.5 Japan TELEC Regulatory Domain 5.2 GHz Band

12.5.1 Panel Antenna Models

The following are the panel antenna models for 5.2 GHz:

<i>Motorola Part Number</i>
ML-5299-WPNA1-01R
ML-2452-PNL9M3-036

12.5.1.1 Panel Antenna Maximum Conducted Transmit Power Settings

The following is a transmit power table (Japanese domain) per panel antenna in the 5 GHz band:

20 MHZ CHANNEL	40 MHZ CHANNEL	LEGACY OFDM RATES (6,9,12,18,24,36,48,54 MBPS)	802.11n HT20 RATES (MCS 0 MCS 15)	802.11n HT40 RATES (MCS 0 MCS 15)
36		12.0	12.0	
38	(36, 40)			18.0
40		12.0	12.0	
42		12.0	12.0	
44		12.0	12.0	
46	(44, 48)			18.0
48		12.0	12.0	
52		12.0	12.0	
54	(52, 56)			18.0
56		12.0	12.0	
60		12.0	12.0	
62	(60, 64)			18.0
64		12.0	12.0	
100		19.0	19.0	
102	(100, 104)			
104		19.0	19.0	
108		19.0	19.0	
112		19.0	19.0	
110	(108, 112)			
116		19.0	19.0	
118	(116, 120)			
120		19.0	19.0	
124		19.0	19.0	

20 MHZ CHANNEL	40 MHZ CHANNEL	LEGACY OFDM RATES (6,9,12,18,24,36,48,54 MBPS)	802.11n HT20 RATES (MCS 0 MCS 15)	802.11n HT40 RATES (MCS 0 MCS 15)
126	(124, 128)			
128		19.0	19.0	
132		19.0	19.0	
134	(132, 136)			
136		19.0	19.0	
140		19.0	19.0	
149				
151	(149, 153)			
153				
157				
159	(157, 161)			
161				
165				

12.5.2 Embedded Antenna Model

The following is the embedded antenna model for 5.2 GHz:

Motorola Part Number
ML-5299-WPNA1-01R

12.5.2.1 Embedded Antenna Maximum Conducted Transmit Power Settings

The following is a transmit power table (Japanese domain) per embedded antenna in the 5 GHz band:

20 MHZ CHANNEL	40 MHZ CHANNEL	LEGACY OFDM RATES (6,9,12,18,24,36,48,54 MBPS)	802.11n HT20 RATES (MCS 0 MCS 15)	802.11n HT40 RATES (MCS 0 MCS 15)
36		10.0	10.0	
38	(36, 40)			7.0
40		10.0	10.0	
42		10.0	10.0	
44		10.0	10.0	
46	(44, 48)			7.0
48		10.0	10.0	
52		10.0	10.0	
54	(52, 56)			7.0
56		10.0	10.0	
60		10.0	10.0	
62	(60, 64)			7.0
64		10.0	10.0	
100		17.0	17.0	
102	(100, 104)			7.0
104		17.0	17.0	
108		17.0	17.0	
112		17.0	17.0	
110	(108, 112)			7.0
116		17.0	17.0	
118	(116, 120)			7.0
120		17.0	17.0	
124		17.0	17.0	
126	(124, 128)			7.0
128		17.0	17.0	

20 MHZ CHANNEL	40 MHZ CHANNEL	LEGACY OFDM RATES (6,9,12,18,24,36,48,54 MBPS)	802.11n HT20 RATES (MCS 0 MCS 15)	802.11n HT40 RATES (MCS 0 MCS 15)
132		17.0	17.0	
134	(132, 136)			7.0
136		17.0	17.0	
140		17.0	17.0	
149				
151	(149, 153)			
153				
157				
159	(157, 161)			
161				
165				

12.5.3 Dipole Antenna Models

The following are the dipole antenna models for 5.2 GHz:

Motorola Part Number
ML-5299-HPA1-01R
ML-2452-APA6J-01
ML-2452-APA2-01

12.5.3.1 Dipole Antenna Maximum Conducted Transmit Power Settings

The following is a transmit power table (Japanese domain) per dipole antenna in the 5 GHz band:

20 MHZ CHANNEL	40 MHZ CHANNEL	LEGACY OFDM RATES (6,9,12,18,24,36,48,54 MBPS)	802.11n HT20 RATES (MCS 0 MCS 15)	802.11n HT40 RATES (MCS 0 MCS 15)
36		12.0	12.0	
38	(36, 40)			9.0
40		12.0	12.0	
42		12.0	12.0	
44		12.0	12.0	
46	(44, 48)			9.0
48		12.0	12.0	
52		12.0	12.0	
54	(52, 56)			9.0
56		12.0	12.0	
60		12.0	12.0	
62	(60, 64)			9.0
64		12.0	12.0	
100		19.0	19.0	
102	(100, 104)			9.0
104		19.0	19.0	
108		19.0	19.0	
112		19.0	19.0	
110	(108, 112)			9.0
116		19.0	19.0	
118	(116, 120)			9.0
120		19.0	19.0	
124		19.0	19.0	
126	(124, 128)			9.0

20 MHZ CHANNEL	40 MHZ CHANNEL	LEGACY OFDM RATES (6,9,12,18,24,36,48,54 MBPS)	802.11n HT20 RATES (MCS 0 MCS 15)	802.11n HT40 RATES (MCS 0 MCS 15)
128		19.0	19.0	
132		19.0	19.0	
134	(132, 136)			9.0
136		19.0	19.0	
140		19.0	19.0	
149				
151	(149, 153)			
153				
157				
159	(157, 161)			
161				
165				

12.5.4 Patch Antenna Model

The following is the patch antenna model for 5.2 GHz:

Motorola Part Number
ML-2452-PTA3M3-036

12.5.4.1 Patch Antenna Maximum Conducted Transmit Power Settings

The following is a transmit power table (Japanese domain) per patch antenna in the 5 GHz band:

20 MHZ CHANNEL	40 MHZ CHANNEL	LEGACY OFDM RATES (6,9,12,18,24,36,48,54 MBPS)	802.11n HT20 RATES (MCS 0 MCS 15)	802.11n HT40 RATES (MCS 0 MCS 15)
36		21.0	21.0	
38	(36, 40)			10.0
40		21.0	21.0	
42		21.0	21.0	
44		21.0	21.0	
46	(44, 48)			10.0
48		21.0	21.0	
52		21.0	21.0	
54	(52, 56)			10.0
56		21.0	21.0	
60		21.0	21.0	
62	(60, 64)			10.0
64		21.0	21.0	
100		20.0	20.0	
102	(100, 104)			17.0
104		20.0	20.0	
108		20.0	20.0	
112		20.0	20.0	
110	(108, 112)			17.0
116		20.0	20.0	
118	(116, 120)			17.0
120		20.0	20.0	
124		20.0	20.0	
126	(124, 128)			17.0
128		20.0	20.0	

20 MHZ CHANNEL	40 MHZ CHANNEL	LEGACY OFDM RATES (6,9,12,18,24,36,48,54 MBPS)	802.11n HT20 RATES (MCS 0 MCS 15)	802.11n HT40 RATES (MCS 0 MCS 15)
132		20.0	20.0	
134	(132, 136)			17.0
136		20.0	20.0	
140		20.0	20.0	
149				
151	(149, 153)			
153				
157				
159	(157, 161)			
161				
165				

AP650 Regulatory Domains

13.1 US Regulatory Domain 2.4 GHz Band

13.1.1 Dipole Antenna Model

The following is the dipole antenna model for 2.4 GHz:

<i>Motorola Part Number</i>
ML-2452-APA2-01

13.1.1.1 Dipole Antenna Maximum Conducted Transmit Power Settings

The following is a transmit power table (US domain) per dipole antenna in the 2.4 GHz band:

20 MHZ CHANNEL	40 MHZ CHANNEL	LEGACY DSSS RATES (1, 2, 5.5, 11 MBPS)	LEGACY OFDM RATES (6,9,12,18,24,36, 48,54 MBPS)	802.11n HT20 RATES (MCS 0 MCS 15)	802.11n HT40 RATES (MCS 0 MCS15)
1		2412	19.5	17.0	16.0
2		2417	19.5	19.0	18.0
3	(1, 5)	2422	21.0	21.0	20.0
4	(2, 6)	2427	21.0	21.0	20.0
5	(3, 7)	2432	21.0	21.0	20.0
6	(4, 8)	2437	21.0	21.0	20.0
7	(5, 9)	2442	21.0	21.0	20.0
8	(6, 10)	2447	21.0	21.0	20.0
9	(7, 11)	2452	21.0	21.0	20.0
10		2457	18.5	18.0	18.0
11		2462	18.5	16.5	16.5

13.1.2 Internal AP650 Dual Band Antenna Models

The following is the internal dual band antenna model for 2.4 GHz:

Motorola Part Number
57RPAA13.G66
57RPAA13.G67
57RPAA13.G68
57RPAA13.G69
57RPAA13.G6A
57RPAA13.G6B

13.1.2.1 AP650 Internal Dual Band Antenna Maximum Conducted Transmit Power Settings

The following is a transmit power table (US domain) per internal dual band antenna in the 2.4 GHz band:

20 MHZ CHANNEL	40 MHZ CHANNEL	LEGACY DSSS RATES (1, 2, 5.5, 11 MBPS)	LEGACY OFDM RATES (6,9,12,18,24,36, 48,54 MBPS)	802.11n HT20 RATES (MCS 0 MCS 15)	802.11n HT40 RATES (MCS 0 MCS15)
1		2412	19.0	16.0	15.0
2		2417	19.0	19.0	18.0
3	(1, 5)	2422	21.0	21.0	20.0
4	(2, 6)	2427	21.0	21.0	20.0
5	(3, 7)	2432	21.0	21.0	20.0
6	(4, 8)	2437	21.0	21.0	20.0
7	(5, 9)	2442	20.0	21.0	20.0
8	(6, 10)	2447	20.0	21.0	20.0
9	(7, 11)	2452	20.0	21.0	20.0
10		2457	20.0	18.0	18.0
11		2462	20.0	16.0	15.0

13.1.3 Indoor Patch Antenna Model

The following is the indoor patch antenna model for 2.4 GHz:

Motorola Part Number
ML-2499- SD3-01R

13.1.3.1 Indoor Patch Antenna Maximum Conducted Transmit Power Settings

The following is a transmit power table (US domain) per Indoor Patch antenna in the 2.4 GHz band:

20 MHZ CHANNEL	40 MHZ CHANNEL	LEGACY DSSS RATES (1, 2, 5.5, 11 MBPS)	LEGACY OFDM RATES (6,9,12,18,24,36, 48,54 MBPS)	802.11n HT20 RATES (MCS 0 MCS 15)	802.11n HT40 RATES (MCS 0 MCS15)
1		19.0	15.5	14.5	
2		19.0	18.0	18.0	
3	(1, 5)	19.5	19.5	19.5	12.0
4	(2, 6)	19.5	19.5	19.5	12.0
5	(3, 7)	19.5	19.5	19.5	12.0
6	(4, 8)	19.5	19.5	19.5	14.5
7	(5, 9)	19.5	19.5	19.5	11.0
8	(6, 10)	19.5	19.5	19.5	11.0
9	(7, 11)	19.5	19.5	19.5	11.0
10		18.5	17.0	17.0	
11		18.5	15.0	14.5	

13.1.4 Outdoor Omni Antenna Model

The following is the Outdoor Omni antenna model for 2.4 GHz:

Motorola Part Number
ML-2499-HPA3-01R

13.1.4.1 Outdoor Omni Antenna Maximum Conducted Transmit Power Settings

The following is a transmit power table (US domain) per outdoor omni antenna in the 2.4 GHz band:

20 MHZ CHANNEL	40 MHZ CHANNEL	LEGACY DSSS RATES (1, 2, 5.5, 11 MBPS)	LEGACY OFDM RATES (6,9,12,18,24,36, 48,54 MBPS)	802.11n HT20 RATES (MCS 0 MCS 15)	802.11n HT40 RATES (MCS0 MCS15)
1		18.5	19.0	13.5	14.0
2		18.5	19.0	16.0	16.0
3	(1, 5)	18.5	21.0	19.0	19.0
4	(2, 6)	18.5	21.0	19.0	19.0
5	(3, 7)	18.5	21.0	19.0	19.0
6	(4, 8)	23.0	21.0	19.0	19.0
7	(5, 9)	19.0	21.0	19.0	19.0
8	(6, 10)	19.0	21.0	19.0	19.0
9	(7, 11)	19.0	21.0	19.0	19.0
10		19.0	19.5	16.0	16.0
11		19.0	19.5	14.0	13.0

13.1.5 Panel Antenna Models

The following is the panel antenna model for 2.4 GHz:

Motorola Part Number
ML-2452-PNA5-01R

13.1.5.1 Panel Antenna Maximum Conducted Transmit Power Settings

The following is a transmit power table (US domain) per panel antenna in the 2.4 GHz band:

20 MHZ CHANNEL	40 MHZ CHANNEL	LEGACY DSSS RATES (1, 2, 5.5, 11 MBPS)	LEGACY OFDM RATES (6,9,12,18,24,36, 48,54 MBPS)	802.11n HT20 RATES (MCS 0 MCS 15)	802.11n HT40 RATES (MCS0 MCS15)
1		16.5	13.0	12.5	
2		18.0	15.0	15.0	
3	(1, 5)	20.0	17.0	18.0	10.0
4	(2, 6)	20.0	17.0	18.0	10.0
5	(3, 7)	20.0	17.0	18.0	10.0
6	(4, 8)	20.0	17.0	18.0	13.0
7	(5, 9)	20.0	17.0	18.0	9.0
8	(6, 10)	20.0	17.0	18.0	9.0
9	(7, 11)	20.0	17.0	18.0	9.0
10		18.0	15.0	15.0	
11		17.0	13.0	12.0	

13.1.6 Omni Antenna Model

The following is the omni antenna model for 2.4 GHz:

Motorola Part Number
ML-2452-PTA3M3-036

13.1.6.1 Omni Antenna Maximum Conducted Transmit Power Settings

The following is a transmit power table (US domain) per omni antenna in the 2.4 GHz band:

20 MHZ CHANNEL	40 MHZ CHANNEL	LEGACY DSSS RATES (1, 2, 5.5, 11 MBPS)	LEGACY OFDM RATES (6,9,12,18,24,36, 48,54 MBPS)	802.11n HT20 RATES (MCS 0 MCS 15)	802.11n HT40 RATES (MCS0 MCS15)
1		17.5	17.5	15.0	13.0
2		17.5	18.0	17.0	16.0
3	(1, 5)	17.5	20.5	19.0	19.0
4	(2, 6)	17.5	20.5	19.0	19.0
5	(3, 7)	17.5	20.5	19.0	19.0
6	(4, 8)	20.5	20.5	19.0	19.0
7	(5, 9)	19.0	20.5	19.0	19.0
8	(6, 10)	19.0	20.5	19.0	19.0
9	(7, 11)	19.0	20.5	19.0	19.0
10		19.0	20.0	16.0	16.5
11		19.0	19.0	13.5	13.5

13.2 US Regulatory Domain 5 GHz Band

13.2.1 Dual Band Dipole Antenna Model

The following is the dual band dipole antenna model for 5 GHz:

<i>Motorola Part Number</i>
ML-2452-APA2-01

13.2.1.1 Dual Band Dipole Antenna Maximum Conducted Transmit Power Settings

The following is a transmit power table (US domain) per dual band dipole antenna in the 5 GHz band:

20 MHZ CHANNEL	40 MHZ CHANNEL	LEGACY OFDM RATES (6,9,12,18,24,36,48,54 MBPS)	802.11n HT20 RATES (MCS 0 MCS 15)	802.11n HT40 RATES (MCS 0 MCS 15)
36		15.5	15.0	
38	(36, 40)	17.0	16.5	12.0
40		18.5	18.0	
42		18.5	18.0	
44		18.5	18.0	
46	(44, 48)	18.0	17.0	16.5
48		17.0	16.0	
52		17.0	16.0	
54	(52, 56)	17.0	17.0	16.5
56		17.0	17.0	
60		17.0	16.0	
62	(60, 64)	17.0	15.0	11.0
64		14.5	14.0	
100		11.5	12.0	
102	(100, 104)	15.0	15.0	10.0
104		19.0	18.0	
108		19.0	18.0	
112		19.0	18.0	
110	(108, 112)	19.0	18.0	18.0
116		19.0	18.0	
118	(116, 120)	19.0	18.0	18.0
120		19.0	18.0	
124		19.0	18.0	
126	(124, 128)	19.0	18.0	18.0

20 MHZ CHANNEL	40 MHZ CHANNEL	LEGACY OFDM RATES (6,9,12,18,24,36,48,54 MBPS)	802.11n HT20 RATES (MCS 0 MCS 15)	802.11n HT40 RATES (MCS 0 MCS 15)
128		19.0	18.0	
132		19.0	18.0	
134	(132, 136)	19.0	18.0	14.0
136		19.0	18.0	
140		19.0	18.0	
149		19.0	18.0	
151	(149, 153)	19.0	18.0	18.0
153		19.0	18.0	
157		19.0	18.0	
159	(157, 161)	19.0	18.0	18.0
161		19.0	18.0	
165		19.0	18.0	

13.2.2 Internal Dual Band Antenna Models

The following are the internal dual band antenna models for 5.2 GHz:

Motorola Part Number
57RPAA13.G66
57RPAA13.G67
57RPAA13.G68
57RPAA13.G69
57RPAA13.G6A
57RPAA13.G6B

13.2.2.1 Internal Dual Band Antenna Maximum Conducted Transmit Power Settings

The following is a transmit power table (US domain) per internal dual band antenna in the 5 GHz band:

20 MHZ CHANNEL	40 MHZ CHANNEL	LEGACY OFDM RATES (6,9,12,18,24,36,48,54 MBPS)	802.11n HT20 RATES (MCS 0 MCS 15)	802.11n HT40 RATES (MCS 0 MCS 15)
36		17.0	16.5	
38	(36,40)	18.0	17.0	12
40		19.0	18.0	
42		19.0	18.0	
44		19.0	18.0	
46	(44,48)	19.0	18.0	13
48		19.0	18.0	
52		19.0	18.0	
54	(52,56)	19.0	18.0	20
56		17.0	18.0	
60		15.0	18.0	
62	(60,64)	15.0	17.0	14
64		14.5	16.0	
100		17.0	18.0	
102	(100,104)	18.0	18.0	8
104		19.0	18.0	
108		19.0	18.0	
112		19.0	18.0	
110	(108,112)	19.0	18.0	19
116		19.0	18.0	
118	(116,120)	19.0	18.0	19
120		19.0	18.0	
124		19.0	18.0	

20 MHZ CHANNEL	40 MHZ CHANNEL	LEGACY OFDM RATES (6,9,12,18,24,36,48,54 MBPS)	802.11n HT20 RATES (MCS 0 MCS 15)	802.11n HT40 RATES (MCS 0 MCS 15)
126	(124,128)	19.0	18.0	19
128		19.0	18.0	
132		19.0	18.0	
134	(132,136)	19.0	18.0	14
136		17.0	17.0	
140		15.5	16.0	
149		19.0	18.0	
151	(149,153)	19.0	18.0	15.0
153		19.0	18.0	
157		19.0	18.0	
159	(157,161)	19.0	18.0	16.0
161		19.0	18.0	
165		19.0	19.0	

13.2.3 Indoor Patch Model

The following is the indoor patch antenna model for 5.2 GHz:

Motorola Part Number
ML-5299-PTA1-01R

13.2.3.1 Indoor Patch Antenna Maximum Conducted Transmit Power Settings

The following is a transmit power table (US domain) per indoor patch antenna in the 5 GHz band:

20 MHZ CHANNEL	40 MHZ CHANNEL	LEGACY OFDM RATES (6,9,12,18,24,36,48,54 MBPS)	802.11n HT20 RATES (MCS 0 MCS 15)	802.11n HT40 RATES (MCS 0 MCS 15)
36		15.5	16.0	
38	(36, 40)	17.5	17.0	12.5
40		19.0	18.0	
42		19.0	18.0	
44		19.0	18.0	
46	(44, 48)	19.0	18.0	18.0
48		19.0	18.0	
52		19.0	18.0	
54	(52, 56)	19.0	18.0	18.0
56		19.0	18.0	
60		18.0	18.0	
62	(60, 64)			13.5
64		16.0	16.0	
100		15.0	15.0	
102	(100, 104)	17.0	16.5	11.5
104		19.0	18.0	
108		19.0	18.0	
112		19.0	18.0	
110	(108, 112)	19.0	18.0	18.0
116		19.0	18.0	
118	(116, 120)	19.0	18.0	18.0
120		19.0	18.0	
124		19.0	18.0	
126	(124, 128)	19.0	18.0	18.0
128		19.0	18.0	

20 MHZ CHANNEL	40 MHZ CHANNEL	LEGACY OFDM RATES (6,9,12,18,24,36,48,54 MBPS)	802.11n HT20 RATES (MCS 0 MCS 15)	802.11n HT40 RATES (MCS 0 MCS 15)
132		19.0	18.0	
134	(132, 136)	19.0	18.0	15.0
136		16.0	16.0	
140		13.5	13.5	
149		19.0	18.0	
151	(149, 153)	19.0	18.0	18.0
153		19.0	18.0	
157		19.0	18.0	
159	(157, 161)	19.0	18.0	18.0
161		19.0	18.0	
165		19.0	18.0	

13.2.4 Outdoor Omni Antenna Model

The following is the outdoor omni antenna models for 5.2 GHz:

Motorola Part Number
ML-5299-HPA1-01R

13.2.4.1 Outdoor Omni Antenna Transmit Power Settings

The following is a transmit power table (US domain) per outdoor omni antenna in the 5 GHz band:

20 MHZ CHANNEL	40 MHZ CHANNEL	LEGACY OFDM RATES (6,9,12,18,24,36,48,54 MBPS)	802.11n HT20 RATES (MCS 0 MCS 15)	802.11n HT40 RATES (MCS 0 MCS 15)
36		14.5	14.5	
38	(36, 40)	17.0	16.5	11.5
40		19.0	18.0	
42		19.0	18.0	
44		19.0	18.0	
46	(44, 48)	19.0	18.0	16.5
48		19.0	18.0	
52		18.5	18.0	
54	(52, 56)	18.5	18.0	17
56		18.5	18.0	
60		18.0	18.0	
62	(60, 64)	16.5		11.5
64		15.0	16.0	
100		14.0	14.0	
102	(100, 104)	16.5	16.0	11.5
104		19.0	18.0	
108		19.0	18.0	
112		19.0	18.0	
110	(108, 112)	19.0	18.0	18.0
116		19.0	18.0	
118	(116, 120)	19.0	18.0	18.0
120		19.0	18.0	
124		19.0	18.0	
126	(124, 128)	19.0	18.0	18.0
128		19.0	18.0	

20 MHZ CHANNEL	40 MHZ CHANNEL	LEGACY OFDM RATES (6,9,12,18,24,36,48,54 MBPS)	802.11n HT20 RATES (MCS 0 MCS 15)	802.11n HT40 RATES (MCS 0 MCS 15)
132		19.0	18.0	
134	(132, 136)	19.0	18.0	15.0
136		16.5	15.0	
140		14.0	12.0	
149		19.0	18.0	
151	(149, 153)	19.0	18.0	18.0
153		19.0	18.0	
157		19.0	18.0	
159	(157, 161)	19.0	18.0	18.0
161		19.0	18.0	
165		19.0	18.0	

13.2.5 Panel Antenna Model

The following is the panel antenna model for 5.2 GHz:

Motorola Part Number
ML-2452-PNA5-01R

13.2.5.1 Panel Antenna Maximum Conducted Transmit Power Settings

The following is a transmit power table (US domain) per panel antenna in the 5 GHz band:

20 MHZ CHANNEL	40 MHZ CHANNEL	LEGACY OFDM RATES (6,9,12,18,24,36,48,54 MBPS)	802.11n HT20 RATES (MCS 0 MCS 15)	802.11n HT40 RATES (MCS 0 MCS 15)
36		14.5	14.0	
38	(36, 40)	16.5	16.0	11.5
40		19.0	18.0	
42		19.0	18.0	
44		19.0	18.0	
46	(44, 48)	19.0	18.0	17.0
48		19.0	18.0	
52		19.0	18.0	
54	(52, 56)	19.0	18.0	18.0
56		19.0	18.0	
60		19.0	18.0	
62	(60, 64)	16.0	16.0	12.0
64		15.0	14.5	
100		12.5	13.5	
102	(100, 104)	15.0	18.0	10.0
104		19.0	18.0	
108		19.0	18.0	
112		19.0	18.0	
110	(108, 112)	19.0	18.0	16.5
116		19.0	18.0	
118	(116, 120)	19.0	18.0	16.5
120		19.0	18.0	
124		19.0	18.0	
126	(124, 128)	19.0	18.0	16.5
128		19.0	18.0	

20 MHZ CHANNEL	40 MHZ CHANNEL	LEGACY OFDM RATES (6,9,12,18,24,36,48,54 MBPS)	802.11n HT20 RATES (MCS 0 MCS 15)	802.11n HT40 RATES (MCS 0 MCS 15)
132		19.0	18.0	
134	(132, 136)	19.0	18.0	13.5
136		14.0	14.0	
140		10.0	11.0	
149		19.0	18.0	
151	(149, 153)	19.0	18.0	18.0
153		19.0	18.0	
157		19.0	18.0	
159	(157, 161)	19.0	18.0	18.0
161		19.0	18.0	
165		19.0	18.0	

13.2.6 Omni Antenna Model

The following is the omni antenna model for 5.2 GHz:

Motorola Part Number
ML-2452-PTA3M3-036

13.2.6.1 Omni Antenna Maximum Conducted Transmit Power Settings

The following is a transmit power table (US domain) per omni antenna in the 5 GHz band:

20 MHZ CHANNEL	40 MHZ CHANNEL	LEGACY OFDM RATES (6,9,12,18,24,36,48,54 MBPS)	802.11n HT20 RATES (MCS 0 MCS 15)	802.11n HT40 RATES (MCS 0 MCS 15)
36		15.0	14.0	
38	(36, 40)	17.0	16.0	10.0
40		19.0	18.0	
42		19.0	18.0	
44		19.0	18.0	
46	(44, 48)	18.0	18.0	16.5
48		18.0	18.0	
52		18.0	17.0	
54	(52, 56)	19.0	18.0	17.0
56		19.0	18.0	
60		19.0	18.0	
62	(60, 64)		16.0	10.5
64		14.0	14.0	
100		12.5	13.5	
102	(100, 104)	16.0	15.0	8.0
104		19.0	18.0	
108		19.0	18.0	
112		19.0	18.0	
110	(108, 112)	19.0	18.0	16.0
116		19.0	18.0	
118	(116, 120)	19.0	18.0	16.0
120		19.0	18.0	
124		19.0	18.0	
126	(124, 128)	19.0	18.0	16.0
128		19.0	18.0	

20 MHZ CHANNEL	40 MHZ CHANNEL	LEGACY OFDM RATES (6,9,12,18,24,36,48,54 MBPS)	802.11n HT20 RATES (MCS 0 MCS 15)	802.11n HT40 RATES (MCS 0 MCS 15)
132		19.0	18.0	
134	(132, 136)	19.0	18.0	13.0
136		14.5	14.5	
140		10.0	12.0	
149		19.0	18.0	
151	(149, 153)	19.0	18.0	18.0
153		19.0	18.0	
157		19.0	18.0	
159	(157, 161)	19.0	18.0	18.0
161		19.0	18.0	
165		19.0	18.0	

13.3 Japan TELEC Regulatory Domain 2.4 GHz Band

13.3.1 Dipole Antenna Model

The following is the dipole antenna model for 2.4 GHz:

<i>Motorola Part Number</i>
ML-2452-APA2-01

13.3.1.1 Dipole Antenna Maximum Conducted Transmit Power Settings

The following is a transmit power table (Japanese domain) per dipole antenna in the 2.4 GHz band:

20 MHZ CHANNEL	40 MHZ CHANNEL	LEGACY DSSS RATES (1, 2, 5.5, 11 MBPS)	LEGACY OFDM RATES (6,9,12,18,24,36, 48,54 MBPS)	802.11n HT20 RATES (MCS 0 MCS 15)	802.11n HT40 RATES (MCS 0 MCS15)
1		2412	13.5	16.0	
2		2417	13.5	15.5	
3	(1, 5)	2422	13.5	15.5	18.5
4	(2, 6)	2427	13.5	15.5	18.5
5	(3, 7)	2432	13.5	15.5	18.5
6	(4, 8)	2437	13.5	15.5	18.5
7	(5, 9)	2442	13.5	15.5	18.5
8	(6, 10)	2447	13.5	15.5	18.5
9	(7, 11)	2452	13.5	15.5	18.5
10		2457	13.5	15.5	
11		2462	13.5	15.5	
12		2467	13.5	15.5	
13		2472	13.5	15.5	
14		2484			

13.3.2 Internal AP650 Dual Band Antenna Models

The following is the internal dual band antenna model for 2.4 GHz:

Motorola Part Number
57RPAA13.G66
57RPAA13.G67
57RPAA13.G68
57RPAA13.G69
57RPAA13.G6A
57RPAA13.G6B

13.3.2.1 AP650 Internal Dual Band Antenna Maximum Conducted Transmit Power Settings

The following is a transmit power table (Japanese domain) per internal dual band antenna in the 2.4 GHz band:

20 MHZ CHANNEL	40 MHZ CHANNEL	LEGACY DSSS RATES (1, 2, 5.5, 11 MBPS)	LEGACY OFDM RATES (6,9,12,18,24,36, 48,54 MBPS)	802.11n HT20 RATES (MCS 0 MCS 15)	802.11n HT40 RATES (MCS 0 MCS15)
1		14.0	16.5		14.0
2		14.0	16.0		14.0
3	(1, 5)	14.0	16.0	18.5	14.0
4	(2, 6)	14.0	16.0	18.5	14.0
5	(3, 7)	14.0	16.0	18.5	14.0
6	(4, 8)	14.0	16.0	18.5	14.0
7	(5, 9)	14.0	16.0	18.5	14.0
8	(6, 10)	14.0	16.0	18.5	14.0
9	(7, 11)	14.0	16.0	18.5	14.0
10		14.0	16.0		14.0
11		14.0	16.0		14.0
12		14.0	16.0		14.0
13		14.5	16.0		14.5
14					

13.3.3 Indoor Patch Antenna Model

The following is the indoor patch antenna model for 2.4 GHz:

Motorola Part Number
ML-2499-SD3-01R

13.3.3.1 Indoor Patch Antenna Maximum Conducted Transmit Power Settings

The following is a transmit power table (Japanese domain) per Indoor Patch antenna in the 2.4 GHz band:

20 MHZ CHANNEL	40 MHZ CHANNEL	LEGACY DSSS RATES (1, 2, 5.5, 11 MBPS)	LEGACY OFDM RATES (6,9,12,18,24,36, 48,54 MBPS)	802.11n HT20 RATES (MCS 0 MCS 15)	802.11n HT40 RATES (MCS 0 MCS15)
1		10.5	13.0	15.5	
2		10.5	13.0	15.0	
3	(1, 5)	10.5	13.0	15.0	18.5
4	(2, 6)	10.5	13.0	15.0	18.5
5	(3, 7)	10.5	13.0	15.0	18.5
6	(4, 8)	10.5	13.0	15.0	18.5
7	(5, 9)	10.5	13.0	15.0	18.5
8	(6, 10)	10.5	13.0	15.0	18.5
9	(7, 11)	10.5	13.0	15.0	18.5
10		10.5	13.0	15.0	
11		10.5	13.0	15.0	
12		10.5	13.0	15.0	
13		10.5	13.0	15.0	
14		11.5			

13.3.4 Outdoor Omni Antenna Model

The following is the outdoor omni antenna model for 2.4 GHz:

Motorola Part Number
ML-2499-HPA3-01R

13.3.4.1 Outdoor Omni Antenna Maximum Conducted Transmit Power Settings

The following is a transmit power table (Japanese domain) per outdoor omni antenna in the 2.4 GHz band:

20 MHZ CHANNEL	40 MHZ CHANNEL	LEGACY DSSS RATES (1, 2, 5.5, 11 MBPS)	LEGACY OFDM RATES (6,9,12,18,24,36, 48,54 MBPS)	802.11n HT20 RATES (MCS 0 MCS 15)	802.11n HT40 RATES (MCS0 MCS15)
1		10.5	13.0	15.5	
2		10.5	13.0	15.0	
3	(1, 5)	10.5	13.0	15.0	18.5
4	(2, 6)	10.5	13.0	15.0	18.5
5	(3, 7)	10.5	13.0	15.0	18.5
6	(4, 8)	10.5	13.0	15.0	18.5
7	(5, 9)	10.5	13.0	15.0	18.5
8	(6, 10)	10.5	13.0	15.0	18.5
9	(7, 11)	10.5	13.0	15.0	18.5
10		10.5	13.0	15.0	
11		10.5	13.0	15.0	
12		10.5	13.0	15.0	
13		10.5	13.0	15.0	
14		11.5			

13.3.5 Panel Antenna Models

The following is the panel antenna model for 2.4 GHz:

Motorola Part Number
ML-2452-PNA5-01R

13.3.5.1 Panel Antenna Maximum Conducted Transmit Power Settings

The following is a transmit power table (Japanese domain) per panel antenna in the 2.4 GHz band:

20 MHZ CHANNEL	40 MHZ CHANNEL	LEGACY DSSS RATES (1, 2, 5.5, 11 MBPS)	LEGACY OFDM RATES (6,9,12,18,24,36, 48,54 MBPS)	802.11n HT20 RATES (MCS 0 MCS 15)	802.11n HT40 RATES (MCS0 MCS15)
1		9.5	12.0	14.5	
2		9.5	12.0	14.0	
3	(1, 5)	9.5	12.0	14.0	18.5
4	(2, 6)	9.5	12.0	14.0	18.5
5	(3, 7)	9.5	12.0	14.0	18.5
6	(4, 8)	9.5	12.0	14.0	18.5
7	(5, 9)	9.5	12.0	14.0	18.5
8	(6, 10)	9.5	12.0	14.0	18.5
9	(7, 11)	9.5	12.0	14.0	18.5
10		9.5	12.0	14.0	
11		9.5	12.0	14.0	
12		9.5	12.0	14.0	
13		9.5	13.0	14.0	
14		10.5			

13.3.6 Omni Antenna Model

The following is the omni antenna model for 2.4 GHz:

Motorola Part Number
ML-2452-PTA3M3-036

13.3.6.1 Omni Antenna Maximum Conducted Transmit Power Settings

The following is a transmit power table (Japanese domain) per omni antenna in the 2.4 GHz band:

20 MHZ CHANNEL	40 MHZ CHANNEL	LEGACY DSSS RATES (1, 2, 5.5, 11 MBPS)	LEGACY OFDM RATES (6,9,12,18,24,36, 48,54 MBPS)	802.11n HT20 RATES (MCS 0 MCS 15)	802.11n HT40 RATES (MCS0 MCS15)
1		11.5	14.0	16.0	
2		11.5	14.0	16.0	
3	(1, 5)	11.5	14.0	16.0	18.5
4	(2, 6)	11.5	14.0	16.0	18.5
5	(3, 7)	11.5	14.0	16.0	18.5
6	(4, 8)	11.5	14.0	16.0	18.5
7	(5, 9)	11.5	14.0	16.0	18.5
8	(6, 10)	11.5	14.0	16.0	18.5
9	(7, 11)	11.5	14.0	16.0	18.5
10		11.5	14.0	16.0	
11		11.5	14.0	16.0	
12		11.5	14.0	16.0	
13		11.5	14.0	16.0	
14		10.0			

13.4 Japan TELEC Regulatory Domain 5 GHz Band

13.4.1 Dual Band Dipole Antenna Model

The following is the dual band dipole antenna model for 5 GHz:

Motorola Part Number
ML-2452-APA2-01

13.4.1.1 Dual Band Dipole Antenna Maximum Conducted Transmit Power Settings

The following is a transmit power table (Japanese domain) per dual band dipole antenna in the 5 GHz band:

20 MHZ CHANNEL	40 MHZ CHANNEL	LEGACY OFDM RATES (6,9,12,18,24,36,48,54 MBPS)	802.11n HT20 RATES (MCS 0 MCS 15)	802.11n HT40 RATES (MCS 0 MCS 15)
36		12.0	14.0	
38	(36, 40)	12.0	14.0	15.5
40		12.0	14.0	
42		12.0	14.0	
44		12.0	14.0	
46	(44, 48)	12.0	14.0	16.0
48		12.0	14.0	
52		12.0	14.0	
54	(52, 56)	12.0	14.0	14.0
56		12.0	14.0	
60		12.0	14.0	
62	(60, 64)	12.0	14.0	15.5
64		12.0	14.0	
100		15.0	14.0	
102	(100, 104)	12.0	14.0	18.0
104		12.0	14.0	
108		12.0	14.0	
112		12.0	14.0	
110	(108, 112)	12.0	14.0	18.0
116		12.0	14.0	
118	(116, 120)	12.0	14.0	18.0
120		15.0	14.0	
124		12.0	14.0	

20 MHZ CHANNEL	40 MHZ CHANNEL	LEGACY OFDM RATES (6,9,12,18,24,36,48,54 MBPS)	802.11n HT20 RATES (MCS 0 MCS 15)	802.11n HT40 RATES (MCS 0 MCS 15)
126	(124, 128)	12.0	14.0	18.0
128		12.0	14.0	
132		12.0	14.0	
134	(132, 136)	12.0	14.0	18.0
136		12.0	14.0	
140		15.0	14.0	
149				
151	(149, 153)			
153				
157				
159	(157, 161)			
161				
165				

13.4.2 Internal Dual Band Antenna Models

The following are the internal dual band antenna models for 5.2 GHz:

Motorola Part Number
57RPAA13.G66
57RPAA13.G67
57RPAA13.G68
57RPAA13.G69
57RPAA13.G6A
57RPAA13.G6B

13.4.2.1 Internal Dual Band Antenna Maximum Conducted Transmit Power Settings

The following is a transmit power table (Japanese domain) per internal dual band antenna in the 5 GHz band:

20 MHZ CHANNEL	40 MHZ CHANNEL	LEGACY OFDM RATES (6,9,12,18,24,36,48,54 MBPS)	802.11n HT20 RATES (MCS 0 MCS 15)	802.11n HT40 RATES (MCS 0 MCS 15)
36		12.0	14.0	
38	(36,40)	12.0	14.0	15.0
40		12.0	14.0	
42		12.0	14.0	
44		12.0	14.0	
46	(44,48)	12.0	14.0	15.5
48		12.0	14.0	
52		12.0	14.0	
54	(52,56)	12.0	14.0	15.5
56		12.0	14.0	
60		12.0	14.0	
62	(60,64)	12.0	14.0	15.5
64		12.0	14.0	
100		15.0	16.5	
102	(100,104)	15.0	16.5	18.0
104		15.0	16.5	
108		15.0	16.5	
112		15.0	16.5	
110	(108,112)	15.0	16.5	18.0
116		15.0	16.5	
118	(116,120)	15.0	16.5	18.0

20 MHZ CHANNEL	40 MHZ CHANNEL	LEGACY OFDM RATES (6,9,12,18,24,36,48,54 MBPS)	802.11n HT20 RATES (MCS 0 MCS 15)	802.11n HT40 RATES (MCS 0 MCS 15)
120		15.0	16.5	
124		15.0	16.5	
126	(124,128)	15.0	16.5	
128		15.0	16.5	
132		15.0	16.5	
134	(132,136)	15.0	16.5	18.0
136		15.0	16.5	
140		15.0	17.0	
149				
151	(149,153)			
153				
157				
159	(157,161)			
161				
165				

13.4.3 Indoor Patch Model

The following is the indoor patch antenna model for 5.2 GHz:

Motorola Part Number
ML-5299-PTA1-01R

13.4.3.1 Indoor Patch Antenna Maximum Conducted Transmit Power Settings

The following is a transmit power table (Japanese domain) per indoor patch antenna in the 5 GHz band:

20 MHZ CHANNEL	40 MHZ CHANNEL	LEGACY OFDM RATES (6,9,12,18,24,36,48,54 MBPS)	802.11n HT20 RATES (MCS 0 MCS 15)	802.11n HT40 RATES (MCS 0 MCS 15)
36		12.0	14.0	
38	(36, 40)	12.0	14.0	15.0
40		12.0	14.0	
42		12.0	14.0	
44		12.0	14.0	
46	(44, 48)	12.0	14.0	15.5
48		12.0	14.0	
52		12.0	14.0	
54	(52, 56)	12.0	14.0	15.5
56		12.0	14.0	
60		12.0	14.0	
62	(60, 64)	12.0	14.0	15.5
64		12.0	14.0	
100		15.0	16.5	
102	(100, 104)	15.0	16.5	18.0
104		15.0	16.5	
108		15.0	16.5	
112		15.0	16.5	
110	(108, 112)	15.0	16.5	18.0
116		15.0	16.5	
118	(116, 120)	15.0	16.5	18.0
120		15.0	16.5	
124		15.0	16.5	
126	(124, 128)	15.0	16.5	18.0
128		15.0	16.5	

20 MHZ CHANNEL	40 MHZ CHANNEL	LEGACY OFDM RATES (6,9,12,18,24,36,48,54 MBPS)	802.11n HT20 RATES (MCS 0 MCS 15)	802.11n HT40 RATES (MCS 0 MCS 15)
132		15.0	16.5	
134	(132, 136)	15.0	16.5	18.0
136		15.0	16.5	
140		15.0	17.0	
149				
151	(149, 153)			
153				
157				
159	(157, 161)			
161				
165				

13.4.4 Outdoor Omni Antenna Model

The following is the outdoor omni antenna models for 5.2 GHz:

Motorola Part Number
ML-5299-HPA1-01R

13.4.4.1 Outdoor Omni Antenna Transmit Power Settings

The following is a transmit power table (Japanese domain) per outdoor omni antenna in the 5 GHz band:

20 MHZ CHANNEL	40 MHZ CHANNEL	LEGACY OFDM RATES (6,9,12,18,24,36,48,54 MBPS)	802.11n HT20 RATES (MCS 0 MCS 15)	802.11n HT40 RATES (MCS 0 MCS 15)
36		11.0	13.0	
38	(36, 40)	12.0	13.0	14.5
40		12.0	13.0	
42		12.0	14.0	
44		12.0	14.0	
46	(44, 48)	12.0	14.0	15.0
48		12.0	13.0	
52		12.0	13.0	
54	(52, 56)	12.0	14.0	15.0
56		12.0	14.0	
60		12.0	13.0	
62	(60, 64)	12.0	14.0	14.5
64		12.0	13.0	
100		15.0	16.5	
102	(100, 104)	15.0	16.5	18.0
104		15.0	16.5	
108		15.0	16.5	
112		15.0	16.5	
110	(108, 112)	15.0	16.5	18.0
116		15.0	16.5	
118	(116, 120)	15.0	16.5	18.0
120		15.0	16.5	
124		15.0	16.5	
126	(124, 128)	15.0	16.5	
128		15.0	16.5	

20 MHZ CHANNEL	40 MHZ CHANNEL	LEGACY OFDM RATES (6,9,12,18,24,36,48,54 MBPS)	802.11n HT20 RATES (MCS 0 MCS 15)	802.11n HT40 RATES (MCS 0 MCS 15)
132		15.0	16.5	
134	(132, 136)	15.0	16.5	18.0
136		15.0	16.5	
140		15.0	16.5	
149				
151	(149, 153)			
153				
157				
159	(157, 161)			
161				
165				

13.4.5 Panel Antenna Model

The following is the panel antenna model for 5.2 GHz:

Motorola Part Number
ML-2452-PNA5-01R

13.4.5.1 Panel Antenna Maximum Conducted Transmit Power Settings

The following is a transmit power table (Japanese domain) per panel antenna in the 5 GHz band:

20 MHZ CHANNEL	40 MHZ CHANNEL	LEGACY OFDM RATES (6,9,12,18,24,36,48,54 MBPS)	802.11n HT20 RATES (MCS 0 MCS 15)	802.11n HT40 RATES (MCS 0 MCS 15)
36		9.0	11.0	
38	(36, 40)	9.0	11.0	13.0
40		9.0	11.0	
42		9.0	11.0	
44		9.0	11.0	
46	(44, 48)	9.0	11.0	13.5
48		9.0	11.0	
52		9.0	11.0	
54	(52, 56)	9.0	11.0	13.5
56		9.0	11.0	
60		9.0	11.0	
62	(60, 64)	9.0	11.0	13.5
64		9.0	11.0	
100		15.0	16.5	
102	(100, 104)	15.0	16.5	18.0
104		15.0	16.5	
108		15.0	16.5	
112		15.0	16.5	
110	(108, 112)	15.0	16.5	18.0
116		15.0	16.5	
118	(116, 120)	15.0	16.5	18.0
120		15.0	16.5	
124		15.0	16.5	
126	(124, 128)	15.0	16.5	
128		15.0	16.5	

20 MHZ CHANNEL	40 MHZ CHANNEL	LEGACY OFDM RATES (6,9,12,18,24,36,48,54 MBPS)	802.11n HT20 RATES (MCS 0 MCS 15)	802.11n HT40 RATES (MCS 0 MCS 15)
132		15.0	16.5	
134	(132, 136)	15.0	16.5	18.0
136		15.0	16.5	
140		15.0	17.0	
149				
151	(149, 153)			
153				
157				
159	(157, 161)			
161				
165				

13.4.6 Omni Antenna Model

The following is the omni antenna model for 5.2 GHz:

Motorola Part Number
ML-2452-PTA3M3-036

13.4.6.1 Omni Antenna Maximum Conducted Transmit Power Settings

The following is a transmit power table (Japanese domain) per omni antenna in the 5 GHz band:

20 MHZ CHANNEL	40 MHZ CHANNEL	LEGACY OFDM RATES (6,9,12,18,24,36,48,54 MBPS)	802.11n HT20 RATES (MCS 0 MCS 15)	802.11n HT40 RATES (MCS 0 MCS 15)
36		11.0	13.0	
38	(36, 40)	11.0	14.0	10.0
40		11.0	13.0	
42		11.0	13.0	
44		11.0	13.0	
46	(44, 48)	11.0	13.0	16.5
48		11.0	13.0	
52		11.0	13.0	
54	(52, 56)	11.0	13.0	17.0
56		11.0	13.0	
60		11.0	13.0	
62	(60, 64)	11.0	13.0	10.5
64		11.0	13.0	
100		15.0	16.5	
102	(100, 104)	15.0	16.5	8.0
104		15.0	16.5	
108		15.0	16.5	
112		15.0	16.5	
110	(108, 112)	15.0	16.5	16.0
116		15.0	16.5	
118	(116, 120)	15.0	16.5	16.0
120		15.0	16.5	
124		15.0	16.5	
126	(124, 128)	15.0	16.5	16.0
128		15.0	16.5	

20 MHZ CHANNEL	40 MHZ CHANNEL	LEGACY OFDM RATES (6,9,12,18,24,36,48,54 MBPS)	802.11n HT20 RATES (MCS 0 MCS 15)	802.11n HT40 RATES (MCS 0 MCS 15)
132		15.0	16.5	
134	(132, 136)	15.0	16.5	13.0
136		15.0	16.5	
140		15.0	17.0	
149				
151	(149, 153)			18.0
153				
157				
159	(157, 161)			18.0
161				
165				

13.5 EU Regulatory Domain 2.4 GHz Band

13.5.1 Dipole Antenna Model

The following is the dipole antenna model for 2.4 GHz:

<i>Motorola Part Number</i>
ML-2452-APA2-01

13.5.1.1 Dipole Antenna Maximum Conducted Transmit Power Settings

The following is a transmit power table (EU domain) per dipole antenna in the 2.4 GHz band:

20 MHZ CHANNEL	40 MHZ CHANNEL	LEGACY DSSS RATES (1, 2, 5.5, 11 MBPS)	LEGACY OFDM RATES (6,9,12,18,24,36, 48,54 MBPS)	802.11n HT20 RATES (MCS 0 MCS 15)	802.11n HT40 RATES (MCS 0 MCS15)
1		13.5	13.5	14.0	
2		13.5	13.5	13.5	
3	(1, 5)	13.5	13.5	13.5	13.5
4	(2, 6)	13.5	13.5	13.5	13.5
5	(3, 7)	13.5	13.5	13.5	13.5
6	(4, 8)	13.5	13.5	13.5	13.5
7	(5, 9)	13.5	13.5	13.5	13.5
8	(6, 10)	13.5	13.5	13.5	13.5
9	(7, 11)	13.5	13.5	13.5	13.5
10		13.5	13.5	13.5	
11		13.5	13.5	13.5	
12		13.5	13.5	13.5	
13		13.5	13.5	13.5	
14					

13.5.2 Internal AP650 Dual Band Antenna Models

The following is the internal dual band antenna model for 2.4 GHz:

Motorola Part Number
57RPAA13.G66
57RPAA13.G67
57RPAA13.G68
57RPAA13.G69
57RPAA13.G6A
57RPAA13.G6B

13.5.2.1 AP650 Internal Dual Band Antenna Maximum Conducted Transmit Power Settings

The following is a transmit power table (EU domain) per internal dual band antenna in the 2.4 GHz band:

20 MHZ CHANNEL	40 MHZ CHANNEL	LEGACY DSSS RATES (1, 2, 5.5, 11 MBPS)	LEGACY OFDM RATES (6,9,12,18,24,36, 48,54 MBPS)	802.11n HT20 RATES (MCS 0 MCS 15)	802.11n HT40 RATES (MCS 0 MCS15)
1		11.5	11.5	11.5	
2		11.5	11.5	11.5	
3	(1, 5)	11.5	11.5	11.5	11.5
4	(2, 6)	11.5	11.5	11.5	11.5
5	(3, 7)	11.5	11.5	11.5	11.5
6	(4, 8)	11.5	11.5	11.5	11.5
7	(5, 9)	11.5	11.5	11.5	11.5
8	(6, 10)	11.5	11.5	11.5	11.5
9	(7, 11)	11.5	11.5	11.5	11.5
10		11.5	11.5	11.5	
11		11.5	11.5	11.5	
12		11.5	11.5	11.5	
13		11.5	11.5	11.5	
14					

13.5.3 Indoor Patch Antenna Model

The following is the indoor patch antenna model for 2.4 GHz:

Motorola Part Number
ML-2499-SD3-01R

13.5.3.1 Indoor Patch Antenna Maximum Conducted Transmit Power Settings

The following is a transmit power table (EU domain) per Indoor Patch antenna in the 2.4 GHz band:

20 MHZ CHANNEL	40 MHZ CHANNEL	LEGACY DSSS RATES (1, 2, 5.5, 11 MBPS)	LEGACY OFDM RATES (6,9,12,18,24,36, 48,54 MBPS)	802.11n HT20 RATES (MCS 0 MCS 15)	802.11n HT40 RATES (MCS 0 MCS15)
1		12.5	13.0	12.0	
2		12.5	13.0	12.0	
3	(1, 5)	12.5	13.0	12.0	12.0
4	(2, 6)	12.5	13.0	12.0	12.0
5	(3, 7)	12.5	13.0	12.0	12.0
6	(4, 8)	12.5	13.0	13.0	12.0
7	(5, 9)	12.5	13.0	11.5	12.0
8	(6, 10)	12.5	13.0	11.5	12.0
9	(7, 11)	12.5	13.0	11.5	12.0
10		12.5	13.0	11.5	
11		12.5	13.0	11.5	
12		12.5	13.0	11.5	
13		12.5	13.0	11.5	
14					

13.5.4 Outdoor Omni Antenna Model

The following is the outdoor omni antenna model for 2.4 GHz:

Motorola Part Number
ML-2499-HPA3-01R

13.5.4.1 Outdoor Omni Antenna Maximum Conducted Transmit Power Settings

The following is a transmit power table (EU domain) per outdoor omni antenna in the 2.4 GHz band:

20 MHZ CHANNEL	40 MHZ CHANNEL	LEGACY DSSS RATES (1, 2, 5.5, 11 MBPS)	LEGACY OFDM RATES (6,9,12,18,24,36, 48,54 MBPS)	802.11n HT20 RATES (MCS 0 MCS 15)	802.11n HT40 RATES (MCS0 MCS15)
1		12.5	12.5	12.0	
2		12.5	12.5	12.0	
3	(1, 5)	12.5	12.5	12.0	12.5
4	(2, 6)	12.5	12.5	12.0	12.5
5	(3, 7)	12.5	12.5	12.0	12.5
6	(4, 8)	12.5	13.0	13.0	12.5
7	(5, 9)	12.5	12.5	11.5	12.5
8	(6, 10)	12.5	12.5	11.5	12.5
9	(7, 11)	12.5	12.5	11.5	12.5
10		12.5	12.5	11.5	
11		12.5	12.5	11.5	
12		12.5	12.5	11.5	
13		12.5	12.5	11.5	
14					

13.5.5 Panel Antenna Models

The following is the panel antenna model for 2.4 GHz:

Motorola Part Number
ML-2452-PNA5-01R

13.5.5.1 Panel Antenna Maximum Conducted Transmit Power Settings

The following is a transmit power table (EU domain) per panel antenna in the 2.4 GHz band:

20 MHZ CHANNEL	40 MHZ CHANNEL	LEGACY DSSS RATES (1, 2, 5.5, 11 MBPS)	LEGACY OFDM RATES (6,9,12,18,24,36, 48,54 MBPS)	802.11n HT20 RATES (MCS 0 MCS 15)	802.11n HT40 RATES (MCS0 MCS15)
1		11.0	11.5	12.0	
2		11.0	11.5	12.0	
3	(1, 5)	11.0	11.5	12.0	11.5
4	(2, 6)	11.0	11.5	12.0	11.5
5	(3, 7)	11.0	11.5	12.0	11.5
6	(4, 8)	11.5	11.5	12.0	11.5
7	(5, 9)	11.5	11.5	12.0	11.5
8	(6, 10)	11.5	11.5	12.0	11.5
9	(7, 11)	11.5	11.5	12.0	11.5
10		11.5	11.5	12.0	
11		11.5	11.5	12.0	
12		11.5	11.5	12.0	
13		11.5	11.5		
14					

13.5.6 Omni Antenna Model

The following is the omni antenna model for 2.4 GHz:

Motorola Part Number
ML-2452-PTA3M3-036

13.5.6.1 Omni Antenna Maximum Conducted Transmit Power Settings

The following is a transmit power table (EU domain) per omni antenna in the 2.4 GHz band:

20 MHZ CHANNEL	40 MHZ CHANNEL	LEGACY DSSS RATES (1, 2, 5.5, 11 MBPS)	LEGACY OFDM RATES (6,9,12,18,24,36, 48,54 MBPS)	802.11n HT20 RATES (MCS 0 MCS 15)	802.11n HT40 RATES (MCS0 MCS15)
1		11.0	11.0	11.0	
2		11.0	11.0	11.0	
3	(1, 5)	11.0	11.0	11.0	11.0
4	(2, 6)	11.0	11.0	11.0	11.0
5	(3, 7)	11.0	11.0	11.0	11.0
6	(4, 8)	11.0	11.0	11.0	11.0
7	(5, 9)	11.0	11.0	11.0	11.0
8	(6, 10)	11.0	11.0	11.0	11.0
9	(7, 11)	11.0	11.0	11.0	11.0
10		11.0	11.0	11.0	
11		11.0	11.0	11.0	
12		11.0	11.0	11.0	
13		11.0	11.0	11.0	
14					

13.6 EU Regulatory Domain 5 GHz Band

13.6.1 Dual Band Dipole Antenna Model

The following is the dual band dipole antenna model for 5 GHz:

<i>Motorola Part Number</i>
ML-2452-APA2-01

13.6.1.1 Dual Band Dipole Antenna Maximum Conducted Transmit Power Settings

The following is a transmit power table (EU domain) per dual band dipole antenna in the 5 GHz band:

20 MHZ CHANNEL	40 MHZ CHANNEL	LEGACY OFDM RATES (6,9,12,18,24,36,48,54 MBPS)	802.11n HT20 RATES (MCS 0 MCS 15)	802.11n HT40 RATES (MCS 0 MCS 15)
36		15.5	15.5	
38	(36, 40)	15.5	15.5	15.5
40		15.5	15.5	
42		15.5	15.5	
44		15.5	15.5	
46	(44, 48)	15.5	15.5	15.5
48		15.5	15.5	
52		15.5	15.5	
54	(52, 56)	15.5	15.5	15.5
56		15.5	15.5	
60		15.5	15.5	
62	(60, 64)	15.5	15.5	15.5
64		15.5	15.5	
100		19.0	18.0	
102	(100, 104)	19.0	19.0	17.5
104		19.0	19.0	
108		19.0	19.0	
112		19.0	19.0	
110	(108, 112)	19.0	19.0	17.5
116		19.0	19.0	
118	(116, 120)	19.0	19.0	17.5
120		19.0	19.0	
124		19.0	19.0	

20 MHZ CHANNEL	40 MHZ CHANNEL	LEGACY OFDM RATES (6,9,12,18,24,36,48,54 MBPS)	802.11n HT20 RATES (MCS 0 MCS 15)	802.11n HT40 RATES (MCS 0 MCS 15)
126	(124, 128)	19.0	19.0	17.5
128		19.0	19.0	
132		19.0	19.0	
134	(132, 136)	19.0	19.0	18.0
136		19.0	19.0	
140		19.0	18.0	
149				
151	(149, 153)			
153				
157				
159	(157, 161)			
161				
165				

13.6.2 Internal Dual Band Antenna Models

The following are the internal dual band antenna models for 5.2 GHz:

Motorola Part Number
57RPAA13.G66
57RPAA13.G67
57RPAA13.G68
57RPAA13.G69
57RPAA13.G6A
57RPAA13.G6B

13.6.2.1 Internal Dual Band Antenna Maximum Conducted Transmit Power Settings

The following is a transmit power table (EU domain) per internal dual band antenna in the 5 GHz band:

20 MHZ CHANNEL	40 MHZ CHANNEL	LEGACY OFDM RATES (6,9,12,18,24,36,48,54 MBPS)	802.11n HT20 RATES (MCS 0 MCS 15)	802.11n HT40 RATES (MCS 0 MCS 15)
36		14.0	14.0	
38	(36,40)	14.0	14.0	14.5
40		14.0	14.0	
42		14.0	14.0	
44		14.0	14.0	
46	(44,48)	14.0	14.0	14.5
48		14.0	14.0	
52		14.0	14.0	
54	(52,56)	14.0	14.0	14.5
56		14.0	14.0	
60		14.0	14.0	
62	(60,64)	14.0	14.0	14.5
64		14.5	14.5	
100		19.0	19.0	
102	(100,104)	19.0	19.0	17.5
104		19.0	19.0	
108		19.0	19.0	
112		19.0	19.0	
110	(108,112)	19.0	19.0	17.5
116		19.0	19.0	
118	(116,120)	19.0	19.0	17.5

20 MHZ CHANNEL	40 MHZ CHANNEL	LEGACY OFDM RATES (6,9,12,18,24,36,48,54 MBPS)	802.11n HT20 RATES (MCS 0 MCS 15)	802.11n HT40 RATES (MCS 0 MCS 15)
120		19.0	19.0	
124		19.0	19.0	
126	(124,128)	19.0	19.0	17.5
128		19.0	19.0	
132		19.0	19.0	
134	(132,136)	19.0	19.0	18.0
136		19.0	19.0	
140		19.0	19.0	
149				
151	(149,153)			
153				
157				
159	(157,161)			
161				
165				

13.6.3 Indoor Patch Model

The following is the indoor patch antenna model for 5.2 GHz:

Motorola Part Number
ML-5299-PTA1-01R

13.6.3.1 Indoor Patch Antenna Maximum Conducted Transmit Power Settings

The following is a transmit power table (EU domain) per indoor patch antenna in the 5 GHz band:

20 MHZ CHANNEL	40 MHZ CHANNEL	LEGACY OFDM RATES (6,9,12,18,24,36,48,54 MBPS)	802.11n HT20 RATES (MCS 0 MCS 15)	802.11n HT40 RATES (MCS 0 MCS 15)
36		13.5	13.5	
38	(36, 40)	13.5	13.5	14.0
40		13.5	13.5	
42		13.5	13.5	
44		13.5	13.5	
46	(44, 48)	13.5	13.5	14.5
48		13.5	13.5	
52		13.5	13.5	
54	(52, 56)	13.5	13.5	14.5
56		13.5	13.5	
60		13.5	13.5	
62	(60, 64)	13.5	13.5	14.5
64		13.5	13.5	
100		19.0	18.0	
102	(100, 104)	19.0	18.0	17.5
104		19.0	18.0	
108		19.0	18.0	
112		19.0	18.0	
110	(108, 112)	19.0	18.0	18.0
116		19.0	18.0	
118	(116, 120)	19.0	18.0	18.0
120		19.0	18.0	
124		19.0	18.0	
126	(124, 128)	19.0	18.0	18.0
128		19.0	18.0	

20 MHZ CHANNEL	40 MHZ CHANNEL	LEGACY OFDM RATES (6,9,12,18,24,36,48,54 MBPS)	802.11n HT20 RATES (MCS 0 MCS 15)	802.11n HT40 RATES (MCS 0 MCS 15)
132		19.0	18.0	
134	(132, 136)	19.0	18.0	18.0
136		19.0	18.0	
140		19.0	18.0	
149				
151	(149, 153)			
153				
157				
159	(157, 161)			
161				
165				

13.6.4 Outdoor Omni Antenna Model

The following is the outdoor omni antenna models for 5.2 GHz:

Motorola Part Number
ML-5299-HPA1-01R

13.6.4.1 Outdoor Omni Antenna Transmit Power Settings

The following is a transmit power table (EU domain) per outdoor omni antenna in the 5 GHz band:

20 MHZ CHANNEL	40 MHZ CHANNEL	LEGACY OFDM RATES (6,9,12,18,24,36,48,54 MBPS)	802.11n HT20 RATES (MCS 0 MCS 15)	802.11n HT40 RATES (MCS 0 MCS 15)
36		13.0	13.0	
38	(36, 40)	13.0	13.0	14.0
40		13.0	13.0	
42		13.0	13.0	
44		13.0	13.0	
46	(44, 48)	13.0	13.0	13.5
48		13.0	13.0	
52		13.0	13.0	
54	(52, 56)	13.0	13.0	13.5
56		13.0	13.0	
60		13.0	13.0	
62	(60, 64)	13.0	13.0	13.5
64		13.0	13.0	
100		19.0	19.0	
102	(100, 104)	19.0	19.0	17.5
104		19.0	19.0	
108		19.0	19.0	
112		19.0	19.0	
110	(108, 112)	19.0	19.0	17.5
116		19.0	19.0	
118	(116, 120)	19.0	19.0	17.5
120		19.0	19.0	
124		19.0	19.0	
126	(124, 128)	19.0	19.0	17.5
128		19.0	19.0	

20 MHZ CHANNEL	40 MHZ CHANNEL	LEGACY OFDM RATES (6,9,12,18,24,36,48,54 MBPS)	802.11n HT20 RATES (MCS 0 MCS 15)	802.11n HT40 RATES (MCS 0 MCS 15)
132		19.0	19.0	
134	(132, 136)	19.0	19.0	18.0
136		19.0	19.0	
140		19.0	19.0	
149				
151	(149, 153)			
153				
157				
159	(157, 161)			
161				
165				

13.6.5 Panel Antenna Model

The following is the panel antenna model for 5.2 GHz:

Motorola Part Number
ML-2452-PNA5-01R

13.6.5.1 Panel Antenna Maximum Conducted Transmit Power Settings

The following is a transmit power table (Japanese domain) per panel antenna in the 5 GHz band:

20 MHZ CHANNEL	40 MHZ CHANNEL	LEGACY OFDM RATES (6,9,12,18,24,36,48,54 MBPS)	802.11n HT20 RATES (MCS 0 MCS 15)	802.11n HT40 RATES (MCS 0 MCS 15)
36		11.0	11.0	
38	(36, 40)	11.0	11.0	11.0
40		11.0	11.0	
42		11.0	11.0	
44		11.0	11.0	
46	(44, 48)	11.0	11.0	11.0
48		11.0	11.0	
52		11.0	11.0	
54	(52, 56)	11.0	11.0	11.0
56		11.0	11.0	
60		11.0	11.0	
62	(60, 64)	11.0	11.0	11.0
64		11.0	11.0	
100		18.0	18.0	
102	(100, 104)	18.0	18.0	17.5
104		18.0	18.0	
108		18.0	18.0	
112		18.0	18.0	
110	(108, 112)	18.0	18.0	17.5
116		18.0	18.0	
118	(116, 120)	18.0	18.0	17.5
120		18.0	18.0	
124		18.0	18.0	
126	(124, 128)	18.0	18.0	
128		18.0	18.0	

20 MHZ CHANNEL	40 MHZ CHANNEL	LEGACY OFDM RATES (6,9,12,18,24,36,48,54 MBPS)	802.11n HT20 RATES (MCS 0 MCS 15)	802.11n HT40 RATES (MCS 0 MCS 15)
132		18.0	18.0	
134	(132, 136)	18.0	18.0	18.0
136		18.0	18.0	
140		18.0	18.0	
149				
151	(149, 153)			
153				
157				
159	(157, 161)			
161				
165				

13.6.6 Omni Antenna Model

The following is the omni antenna model for 5.2 GHz:

Motorola Part Number
ML-2452-PTA3M3-036

13.6.6.1 Omni Antenna Maximum Conducted Transmit Power Settings

The following is a transmit power table (EU domain) per omni antenna in the 5 GHz band:

20 MHZ CHANNEL	40 MHZ CHANNEL	LEGACY OFDM RATES (6,9,12,18,24,36,48,54 MBPS)	802.11n HT20 RATES (MCS 0 MCS 15)	802.11n HT40 RATES (MCS 0 MCS 15)
36		13.0	13.0	
38	(36, 40)	13.0	13.0	14.0
40		13.0	13.0	
42		13.0	13.0	
44		13.0	13.0	
46	(44, 48)	13.0	13.0	13.5
48		13.0	13.0	
52		13.0	13.0	
54	(52, 56)	13.0	13.0	13.5
56		13.0	13.0	
60		13.0	13.0	
62	(60, 64)	13.0	13.0	13.5
64		13.0	13.0	
100		19.0	19.0	
102	(100, 104)	19.0	19.0	17.5
104		19.0	19.0	
108		19.0	19.0	
112		19.0	19.0	
110	(108, 112)	19.0	19.0	17.5
116		19.0	19.0	
118	(116, 120)	19.0	19.0	17.5
120		19.0	19.0	
124		19.0	19.0	
126	(124, 128)	19.0	19.0	17.5
128		19.0	19.0	

20 MHZ CHANNEL	40 MHZ CHANNEL	LEGACY OFDM RATES (6,9,12,18,24,36,48,54 MBPS)	802.11n HT20 RATES (MCS 0 MCS 15)	802.11n HT40 RATES (MCS 0 MCS 15)
132		19.0	19.0	
134	(132, 136)	19.0	19.0	18.0
136		19.0	19.0	
140		19.0	19.0	
149				
151	(149, 153)			
153				
157				
159	(157, 161)			
161				
165				



Technical Support

Comprehensive on-line support is available at the Support Central site at <http://www.symbol.com/support/>. Support Central provides our customers with a wealth of information and online assistance including developer tools, software downloads, product manuals and online repair requests.

When contacting the Motorola Support Center, please provide the following information:

- *serial number of unit*
- *model number or product name*
- *software type and version number.*

North American Contacts

Support (for warranty and service information):

telephone: 1-800-653-5350

fax: (631) 738-5410

Email: emb.support@motorola.com

International Contacts

Outside North America:

Motorola, inc.

Symbol Place

Winnersh Triangle, Berkshire, RG41 5TP

United Kingdom

0800-328-2424 (Inside UK)

+44 118 945 7529 (Outside UK)

Web Support Sites

Product Downloads

<http://www.symbol.com/downloads>

Manuals

<http://support.symbol.com/support/product/manuals.do>

Additional Information

Obtain additional information by contacting Motorola at:

1-800-722-6234, inside North America

+1-516-738-5200, in/outside North America

<http://www.motorola.com/>



MOTOROLA INC.
1303 E. ALGONQUIN ROAD
SCHAUMBURG, IL 60196
<http://www.motorola.com>

72E-133063-01 Revision A
December 2009